

VRF AIR-CONDITIONER
[HEAT PUMP]

Technical, Installation and Service Handbook

Hi-FLEXi X3 series

BASIC MODELS

AVWT-76HKFXE
AVWT-96HKFXE
AVWT-114HKFXE
AVWT-136HKFXE
AVWT-154HKFXE
AVWT-170HKFXE
AVWT-190HKFXE
AVWT-212HKFXE
AVWT-232HKFXE
AVWT-250HKFXE
AVWT-272HKFXE

Combination Models

AVWT-290~1088HKFXE



Dear customers:

Thank you for choosing and using our products. For your better understanding and use of this product, be sure to read and comply with the following items before use.

IMPORTANT NOTICE

Signal words (danger, warning and caution) are used to identify severity of hazard. Definitions for identifying hazard severity are provided below with their respective signal words.



: Indicates a hazardous situation which, if not avoided, will result in death or serious injury.



: Indicates a hazardous situation which, if not avoided, could result in death or serious injury.



: Used with the safety alert symbol, indicates a hazardous situation which, if not avoided, could result in minor or moderate injury.

NOTE

: Useful information for operation and/or maintenance.

- This manual should be considered as a permanent part of the air conditioning equipment and should remain with the air conditioning equipment.
- This manual gives a common description and information for this air conditioner which you operate as well for other models.
- HISENSE pursues a policy of continuing improvement in design and performance of products. The right is therefore reserved to vary specifications without notice.
- HISENSE cannot anticipate every possible circumstance that might involve a potential hazard. This air conditioner is designed for standard air conditioning only. Do not use this air conditioner for other purposes such as drying clothes, refrigerating foods or for any other cooling or heating process.
- Do not install the unit in the following places, otherwise, it may lead to a fire, deformation, corrosion or failure.
 - * Places where oil (including machinery oil) splashes.
 - * Places where sulfide gas drifts such as in hot spring.
 - * Places where flammable gas may generate or flow.
 - * Places where strong wind with high salinity blows such as coast regions, or places with an atmosphere of acidity or alkalinity.
- Do not install the unit in the place where silicon gas drifts. If the silicon gas attaches to the surface of heat exchanger, the fin surface repels water. As a result, drain water splashes outside of the drain pan and splashed water runs inside of electrical box. In the end, water leakage or electrical devices failure may occur.
- Do not install the unit in the place where the breeze directly catches the animals and plants. It could adversely affect the animals and plants.
- Installation and service engineering must comply with local standards, laws and regulations.
- As public inaccessible appliances, the indoor units are required to be installed at a height of no lower than 2.5m.
- The installation of the air conditioner can only be carried out by the dealer or professionals. Installation by customers themselves may lead to water leakage, electric shock or a fire.
- If you have any questions, please contact your dealer or designated service center of HISENSE.
- To protect the environment, please do not discard the product at will, and HISENSE can provide recycling services in accordance with the relevant provisions of the country and provide replaceable parts in accordance with national standard requirements.
- This air conditioner has been designed for the following temperatures, please operate the air conditioner within the ranges.

Temperature		(°C)	
		Maximum(DB/WB)	Minimum(DB/WB)
Cooling Operation	Indoor	32/23*	21/15
	Outdoor	54*	-5
Heating Operation	Indoor	27	15
	Outdoor	24/16.5	-20/-21

DB: Dry Bulb, WB: Wet Bulb

NOTE:

(*) 48°C DB ~ 54°C DB , operation control range. Outdoor is 54°C DB, the Maximum for indoor is 28°C DB. The temperature may vary along with the outdoor units.

⚠ DANGER

- Do not perform installation work, refrigerant piping work, drain pump installation, drain piping and electrical wiring without referring to installation manual. If the instructions are not followed, it may lead to water leakage, electric shock or a fire. In case of fire, cut off the power at the first time; do not touch the electrical parts by hand to avoid electric shock.
- These products are equipped with electrical parts, so do not pour water into the indoor units or outdoor units, or it will lead to a serious electrical failure.
- Do not open the service cover of the indoor or outdoor units without turning OFF the main power supply, otherwise it may lead to a serious accident. (In any cases, users are not allowed to open the service cover).
- Do not touch or adjust safety devices inside the indoor or outdoor units. Otherwise, it may lead to a serious accident.
- Refrigerant R410A for this unit is incombustible, non-toxic and odorless; however if the refrigerant leaked and contacted with fire, toxic gas will generate. Also because the R410A is heavier than air, its accumulation near floor surface could lead to difficult breathing. Turn OFF the main switch, extinguish any naked flames and contact your service contractor, if refrigerant leakage occurs. Do not charge oxygen, acetylene or other flammable and poisonous gases into the refrigeration cycle when performing a leak test or an air-tightness test. These types of gases can lead to an explosion. It is recommended that nitrogen be used for these tests.
- Refrigerant safety leakage standards for construction and operation systems are determined in accordance with local regulations or standards.
- Use an ELB (Earth Leakage Breaker, with an actuation time of 0.1s or less) at or above medium induction speed, otherwise it may lead to an electric shock or a fire.
- For installation, firmly connect the refrigerant pipe before the compressor starts operating.
- For maintenance, relocation and disposal, remove the refrigerant pipe after the compressor stops.
- Do not perform a short-circuit to the protection device such as a pressure switch when operating. It may lead to a fire or explosion.

⚠ WARNING

- Do not use any sprays such as insecticide, lacquer, hair spray or other flammable gases within approximately one (1) meter from the system.
- If circuit breaker is frequently activated, stop the system and contact your or service contractor.
- Check that the earth wire is securely connected. If the unit is not properly earthed, it may lead to electric shock. Do not connect the earth wire to gas piping, water piping, lighting conductor or earth wire of a telephone.
- Before performing any brazing work, check to ensure that there is no flammable materials around. When charging refrigerant be sure to wear leather gloves to prevent from cold injuries.
- Protect the wires, electrical parts and the like from rats or other small animals. If not, rats may gnaw at unprotected parts, which may lead to a fire.
- Fix the cables securely. External forces on the terminals could lead to a fire.
- Provide a sufficiently strong foundation. If not, the unit may fall down and it may lead to injuries.
- Perform electrical work according to installation manual, relevant regulations and standards.
- If the instructions are not followed, an electrical failure and a fire may occur due to insufficient capacity and inadequate performance. Use specified cables between units, otherwise, an electrical failure or a fire may occur. Ensure that the outdoor unit is not covered with ice or snow before use.
- This appliance can be used by children aged from 8 years and above, and persons with reduced physical, sensory or mental capabilities or lack of experience and knowledge if they have been given supervision or instruction concerning use of the appliance in a safe way and understand the hazards involved. Children shall not play with the appliance. Cleaning and maintenance shall not be done by children without supervision.
- The A-weighted emission sound pressure level at workstations does not exceed 70 dB(A).

⚠ CAUTION

- Do not step on or put any objects on the product.
- Do not put any foreign materials on or inside the unit.
- Do not install the indoor unit, outdoor unit, remote control switch and cable within approximately 3 meters from strong electromagnetic wave radiators such as medical equipment.
- Starting the unit after longtime idleness requires the compressor temperature to meet the starting requirements or reach a certain heating time.

NOTE:

- It is recommended that the room will be ventilated every 3 to 4 hours.
In some cases, the air conditioner may not work properly in the following cases.
- * In case that the power supplied by the power transformer is less than or equal to the electric power of the air conditioner.
- * In case that the large power-consuming equipment is too close to the power supply wiring of the air conditioner, large surge voltage may be inducted in the power supply wiring of the air conditioner.
- The cooling capacity may decrease according to the outdoor air temperature. Therefore, it is recommended that auxiliary equipment be used on the job site when the unit is installed in a high temperature region.
- The repair and maintenance of this air conditioner can only be carried out by professionals.

IMPORTANT NOTICE



Correct Disposal of this product

This marking indicates that this product should not be disposed with other household wastes. To prevent possible harms to the environment or human health from uncontrolled waste disposal, recycle it responsibly to promote the sustainable reuse of material resources. Please return your used device through the return and collection systems or to contact your retailers, they can take this product for environmentally safe recycling.

CHECKING UPON DELIVERY

- Upon receiving this product, inspect it for any shipping damage.
Claims for damage, either apparent or concealed, in a written form, should be filed immediately with the shipping company.
- Check the model number, electrical characteristics (power supply, voltage and frequency) and accessories to determine if they are correct. The standard utilization of the unit shall be explained in these instructions. Please contact your local agent, as the occasion arises.

HISENSE's liability shall not cover defects arising from the alteration performed by customers without HISENSE's consent in a written form.

CONTENT

DESIGN

1. Introduction	1
1.1 Line-Up of Outdoor Unit	1
1.2 Application Case	7
1.3 Combination	8
2. General Data	10
2.1 General Data	10
2.2 Component Data	24
2.3 Safety and Control Device Setting	26
2.4 Sound Data	27
2.5 Dimensional Data	30
2.6 Structure	34
3. Piping System	37
3.1 Connection of Refrigerant Pipes for Standard Combination Models	37
3.2 Pipe Connection Design Guidance	44
3.3 Calculation of Additional Refrigerant	47
3.4 Piping Connection Kit Dimensions (optional)	49
4. Capacities and Selection Data	52
4.1 Procedure for Selection of the System	52
4.1.1 Unique Features of the System	52
4.1.2 Selection Parameters	53
4.1.3 Check Points for System Installation	53
4.1.4 Selection procedure example	55
4.2 Capacity Correction Based on Refrigerant Piping Length	57
4.3 Correction Factor According to Defrosting Operation	59
5. Control System	60
5.1 Refrigerant Cycle	60
5.2 Control Logic	62
5.3 Standard Operation Procedure Chart	63
5.4 Electrical wiring diagram	72

INSTALLATION

1. Before Installation	75
1.1 Outdoor Unit & Refrigerant Cycle	75
1.2 Necessary Tools and Instrument List for Installation	75
2. Transportation and Handling	77
2.1 Transportation	77
2.2 Hanging Method	78
3. Outdoor Unit Installation	79
3.1 Service Space	79
3.2 Factory-Supplied Accessories	81
3.3 Installation Conditions	81
3.4 Foundation	82
3.5 Drainage	84
4. Refrigerant Piping Work	86
4.1 Piping Materials	86
4.2 Flaring and Joint	87
4.3 Caution to Outdoor Unit Installation	88
4.4 Piping Connection	90
4.4.1 Stop Valve	91
4.4.2 Piping Connection	92
5. Electrical Wiring	94
5.1 General Check	94
5.2 Wiring	95
5.3 Electrical Wiring Connection	97

5.4	Electrical Wiring Connection of The System.....	98
5.5	DIP Switch Setting of Outdoor Unit.....	100
6.	Additional Refrigerant Charge.....	103
6.1	Air-Tightness Test.....	103
6.2	Vacuuming.....	104
6.3	Charging.....	104
7.	Test Run.....	106
7.1	Before Test Run.....	106
7.2	Test Run.....	107

SERVICE

1.	Troubleshooting.....	110
1.1	Initial Troubleshooting.....	110
1.1.1	Checking of Electrical Wiring and Power Source.....	110
1.1.2	Checking of Rotary Switch and Dip Switch Setting.....	110
1.1.3	Checking by 7-Segment Display.....	112
1.1.4	Checking of Alarm Code History.....	113
1.1.5	Emergency Operation.....	116
1.1.6	One-Key Refrigerant Recovery.....	121
1.1.7	Failure of Power Supply to Indoor Unit and Remote Control Switch.....	130
1.1.8	Abnormal Transmission between Remote Control Switch and Indoor Unit.....	131
1.1.9	Abnormalities of Devices.....	132
1.2	Troubleshooting Procedure.....	140
1.2.1	Alarm Code Table.....	140
1.2.2	Troubleshooting by Alarm Code.....	142
1.2.3	Troubleshooting in Check Mode by Remote Control Switch.....	198
1.2.4	Troubleshooting by 7-Segment Display.....	205
1.2.5	Function of RSW, DSWs and LEDs.....	213
2.	Servicing.....	223
2.1	Removing Front Service Cover.....	223
2.2	Attaching Front Service Cover.....	224
2.3	Removing Top Cover.....	225
2.4	Removing Shroud.....	226
2.5	Removing Electrical Box Cover.....	227
2.6	Removing Electrical Box.....	228
2.7	Removing E-Box Stay.....	229
2.8	Removing Air Grille.....	230
2.9	Removing Outdoor Fan.....	231
2.10	Removing Compressor.....	233
2.11	Replacing Refrigerant Oil.....	243
2.11.1	Replacing Refrigerant Oil (No Clogging in Return Oil Circuit).....	243
2.11.2	Replacing Refrigerant Oil (Clogging in Return Oil Circuit) and Replacing Return Oil Circuit.....	244
2.12	Removing Coils.....	247
2.12.1	Removing Expansion Valve Coil (EVB, EVO).....	249
2.12.2	Removing Solenoid Valve Coil (SVA).....	250
2.12.3	Removing Solenoid Valve (SVA).....	251
2.12.4	Removing Reversing Valve Coil (RVR).....	252
2.12.5	Removing Reversing Valve.....	253
2.13	Removing Stop Valve.....	255
2.14	Removing High Pressure Switch, High Pressure Sensor, Low Pressure Sensor and.....	256
2.14.1	Removing High Pressure Switch (PSH1 and PSH2).....	258
2.15	Removing Thermistor for Liquid Pipe.....	259
2.16	Removing Thermistor for Ambient Temperature.....	260
2.17	Removing Other Electrical Components.....	261
2.17.1	Removing Outdoor Unit PCB and Electrical Components for Electrical Box.....	262
2.17.2	Removing Inverter PCB.....	265
2.17.3	Mount the electrical box in the reverse procedure.....	266

3. Main Parts	267
3.1 Inverter.....	267
3.1.1 Specifications of Inverter.....	267
3.1.2 Arrangement of Inverter Power Unit.....	268
3.1.3 Protective Function.....	269
3.1.4 Overload Protection Control.....	270
3.2 Electronic Expansion Valve.....	271
3.3 Pressure Sensor.....	272
3.4 Noise Filter (NF1, NF2).....	273
3.5 Reactor (DCL1,DCL2).....	275
4. Optional Function	276
4.1 Setting Method.....	276
4.2 External Input and Output Setting.....	277
4.2.1 Input Fixing Heating Operation Mode (Control Function No.1), Input Fixing Cooling Operation Mode (Control Function No.2).....	279
4.2.2 Input Demand Stoppage (Control Function No.3).....	279
4.2.3 Input Outdoor Fan Motor Start/Stop (Control Function No.4).....	280
4.2.4 Input Forced Stoppage (Control Function No.5).....	281
4.2.5 Input Demand Current Control 40, 60, 70, 80, 100% (Control Function No.6 to 10).....	281
4.2.6 Input Low Noise Setting 1,2, 3 (Control Function No.11 to 13).....	282
4.2.7 Output Operation Signal (Control Function No.1).....	284
4.2.8 Output Alarm Signal (Control Function No.2).....	284
4.2.9 Output Compressor ON Signal (Control Function No.3).....	285
4.2.10 Output Defrosting Signal (Control Function No.4).....	285
4.3 Function Setting.....	286
4.3.1 Circulator Function at Heating Thermo-OFF (Control Function FA).....	288
4.3.2 Night-Shift (Low Noise).....	289
4.3.3 Cancellation of Outdoor Ambient Temperature Limit.....	290
4.3.4 Defrost for Cold Area (Change of Defrost Condition).....	290
4.3.5 SLo (Fan Speed) Defrost Setting.....	291
4.3.6 Priority Capacity Mode Setting.....	291
4.3.7 Low Noise Setting.....	291
4.3.8 Demand Function Setting.....	292
4.3.9 Wave Function Setting.....	293
4.3.10 Cold Draft Protection.....	293
4.3.11 Adjustment of Fan Rotation.....	293
4.3.12 Intermittent Operation of Outdoor Fan Motor.....	294
4.3.13 Function Setting.....	295
5. Field Work Instruction	297
5.1 Caution for Refrigerant Leakage.....	297
5.2 Maintenance Work.....	298
5.3 Service and Maintenance Record by 7-Segment Display.....	299
5.4 Service and Maintenance Record by Remote Control Switch.....	300
5.5 Service & Maintenance Record.....	301
5.6 Saturation Curve for Refrigerant.....	302
5.7 Mollier Chart for R410A.....	303
6. Test Run	304
6.1 Before test run.....	304
6.2 Test Run.....	305
6.2.1 Test Run by Remote Control Switch.....	305
6.2.2 Test Run from Outdoor Unit Side.....	305
6.2.3 Checking at Test Run.....	307
6.2.4 Checking List for Refrigerant Cycle.....	308

DESIGN



1. Introduction

1.1 Line-Up of Outdoor Unit

【Basic Unit】

Capacity kBtu/h (HP)	76(8HP)	96(10HP)	114(12HP)	136(14HP)	154(16HP)
Model	AVWT-76HKFXE	AVWT-96HKFXE	AVWT-114HKFXE	AVWT-136HKFXE	AVWT-154HKFXE
Capacity kBtu/h (HP)	170(18HP)	190(20HP)	212(22HP)	232(24HP)	250(26HP)
Model	AVWT-170HKFXE	AVWT-190HKFXE	AVWT-212HKFXE	AVWT-232HKFXE	AVWT-250HKFXE
Capacity kBtu/h (HP)	272(28HP)				
Model	AVWT-272HKFXE				

Model 76~114



Model 136~170



Model 190~232



Model 250~272



【Standard Combination Models】 ※

Capacity kBtu/h (HP)	290(30HP)	308(32HP)	326(34HP)	344(36HP)	366(38HP)
Model	AVWT-290HKFXE	AVWT-308HKFXE	AVWT-326HKFXE	AVWT-344HKFXE	AVWT-366HKFXE
Combination	AVWT-154HKFXE	AVWT-154HKFXE	AVWT-190HKFXE	AVWT-190HKFXE	AVWT-212HKFXE
	AVWT-136HKFXE	AVWT-154HKFXE	AVWT-136HKFXE	AVWT-154HKFXE	AVWT-154HKFXE
	—	—	—	—	—
	—	—	—	—	—

Capacity kBtu/h (HP)	386(40HP)	402(42HP)	422(44HP)	444(46HP)	464(48HP)
Model	AVWT-386HKFXE	AVWT-402HKFXE	AVWT-422HKFXE	AVWT-444HKFXE	AVWT-464HKFXE
Combination	AVWT-232HKFXE	AVWT-212HKFXE	AVWT-232HKFXE	AVWT-232HKFXE	AVWT-232HKFXE
	AVWT-154HKFXE	AVWT-190HKFXE	AVWT-190HKFXE	AVWT-212HKFXE	AVWT-232HKFXE
	—	—	—	—	—
	—	—	—	—	—

Capacity kBtu/h (HP)	482(50HP)	504(52HP)	522(54HP)	544(56HP)	556(58HP)
Model	AVWT-482HKFXE	AVWT-504HKFXE	AVWT-522HKFXE	AVWT-544HKFXE	AVWT-556HKFXE
Combination	AVWT-250HKFXE	AVWT-272HKFXE	AVWT-272HKFXE	AVWT-272HKFXE	AVWT-212HKFXE
	AVWT-232HKFXE	AVWT-232HKFXE	AVWT-250HKFXE	AVWT-272HKFXE	AVWT-190HKFXE
	—	—	—	—	AVWT-154HKFXE
	—	—	—	—	—

Capacity kBtu/h (HP)	576(60HP)	598(62HP)	618(64HP)	634(66HP)	654(68HP)
Model	AVWT-576HKFXE	AVWT-598HKFXE	AVWT-618HKFXE	AVWT-634HKFXE	AVWT-654HKFXE
Combination	AVWT-232HKFXE	AVWT-232HKFXE	AVWT-232HKFXE	AVWT-232HKFXE	AVWT-232HKFXE
	AVWT-190HKFXE	AVWT-212HKFXE	AVWT-232HKFXE	AVWT-212HKFXE	AVWT-232HKFXE
	AVWT-154HKFXE	AVWT-154HKFXE	AVWT-154HKFXE	AVWT-190HKFXE	AVWT-190HKFXE
	—	—	—	—	—

Capacity kBtu/h (HP)	676(70HP)	696(72HP)	714(74HP)	732(76HP)	754(78HP)
Model	AVWT-676HKFXE	AVWT-696HKFXE	AVWT-714HKFXE	AVWT-732HKFXE	AVWT-754HKFXE
Combination	AVWT-232HKFXE	AVWT-232HKFXE	AVWT-250HKFXE	AVWT-250HKFXE	AVWT-272HKFXE
	AVWT-232HKFXE	AVWT-232HKFXE	AVWT-232HKFXE	AVWT-250HKFXE	AVWT-250HKFXE
	AVWT-212HKFXE	AVWT-232HKFXE	AVWT-232HKFXE	AVWT-232HKFXE	AVWT-232HKFXE
	—	—	—	—	—

Capacity kBtu/h (HP)	776(80HP)	794(82HP)	816(84HP)	824(86HP)	844(88HP)
Model	AVWT-776HKFXE	AVWT-794HKFXE	AVWT-816HKFXE	AVWT-824HKFXE	AVWT-844HKFXE
Combination	AVWT-272HKFXE	AVWT-272HKFXE	AVWT-272HKFXE	AVWT-232HKFXE	AVWT-232HKFXE
	AVWT-272HKFXE	AVWT-272HKFXE	AVWT-272HKFXE	AVWT-212HKFXE	AVWT-232HKFXE
	AVWT-232HKFXE	AVWT-250HKFXE	AVWT-272HKFXE	AVWT-190HKFXE	AVWT-190HKFXE
	—	—	—	AVWT-190HKFXE	AVWT-190HKFXE

Capacity kBtu/h (HP)	866(90HP)	886(92HP)	908(94HP)	928(96HP)	946(98HP)
Model	AVWT-866HKFXE	AVWT-886HKFXE	AVWT-908HKFXE	AVWT-928HKFXE	AVWT-946HKFXE
Combination	AVWT-232HKFXE	AVWT-232HKFXE	AVWT-232HKFXE	AVWT-232HKFXE	AVWT-250HKFXE
	AVWT-232HKFXE	AVWT-232HKFXE	AVWT-232HKFXE	AVWT-232HKFXE	AVWT-232HKFXE
	AVWT-212HKFXE	AVWT-232HKFXE	AVWT-232HKFXE	AVWT-232HKFXE	AVWT-232HKFXE
	AVWT-190HKFXE	AVWT-190HKFXE	AVWT-212HKFXE	AVWT-232HKFXE	AVWT-232HKFXE

Capacity kBtu/h (HP)	968(100HP)	986(102HP)	1008(104HP)	1026(106HP)	1048(108HP)
Model	AVWT-968HKFXE	AVWT-986HKFXE	AVWT-1008HKFXE	AVWT-1026HKFXE	AVWT-1048HKFXE
Combination	AVWT-272HKFXE	AVWT-272HKFXE	AVWT-272HKFXE	AVWT-272HKFXE	AVWT-272HKFXE
	AVWT-232HKFXE	AVWT-250HKFXE	AVWT-272HKFXE	AVWT-272HKFXE	AVWT-272HKFXE
	AVWT-232HKFXE	AVWT-232HKFXE	AVWT-232HKFXE	AVWT-250HKFXE	AVWT-272HKFXE
	AVWT-232HKFXE	AVWT-232HKFXE	AVWT-232HKFXE	AVWT-232HKFXE	AVWT-232HKFXE

Capacity kBtu/h (HP)	1066(110HP)	1088(112HP)
Model	AVWT-1066HKFXE	AVWT-1088HKFXE
Combination	AVWT-272HKFXE	AVWT-272HKFXE
	AVWT-272HKFXE	AVWT-272HKFXE
	AVWT-272HKFXE	AVWT-272HKFXE
	AVWT-250HKFXE	AVWT-272HKFXE

※ Combine the specified basic units as shown in the table above. In addition, the rules of the combination method are that the same frame can be freely combined (Except for the 76/96/114/170 model, which do not participate in the module combination).

【Standard Combination Models】

Model 290~308



Model 326/386



Model 402~464



Model 482~504



Model 522~544



Model 556~618



Model 634~696



Model 714



Model 732~776



Model 794~816



Model 824~928



Model 946~968



Model 986~1008



Model 1026~1048

















Model 1066~1088



1.2 Application Case

The following indoor units can be combined with the outdoor unit.

Table 1.1 Indoor Unit Type List

Type	Picture	Nominal Power (kBtu/h)																					
		05	07	09	12	14	15	17	18	19	22	24	27	28	30	38	48	54	76	96	114	154	190
4-way Cassette Type				●	●		●			●	●	●	●		●	●	●	●					
Mini 4-way Cassette Type		●	●	●	●		●	●		●													
1-way Cassette Type			●	●	●	●			●			●											
2-way Cassette Type			●	●	●	●			●			●	●		●	●	●	●					
Console Type		●	●	●	●		●	●															
Ceiling Ducted Type (High Static Pressure)			●	●	●		●			●	●	●	●		●	●	●	●	●	●			
Ceiling Ducted Type (Low Static Pressure)			●	●	●	●		●		●	●	●	●		●	●	●	●					
Ceiling Ducted Type (DC Lowheight)		●	●	●	●		●	●		●	●	●											
Ceiling Ducted Type (AC Lowheight)		●	●	●	●		●	●		●	●	●											
Ceiling Ducted Type (DC Dynamic Static Pressure)			●	●	●		●			●	●	●			●	●	●	●	●	●			
Wall Mounted Type		●	●	●	●		●	●			●		●										
Ceiling & Floor Type								●	●		●	●	●		●	●	●						
Floor Concealed Type				●		●			●			●											
All Fresh Air Indoor Unit															●		●		●	●	●	●	●

● : Available

1.3 Combination

Utilizing an inverter control, a wide range of operation capacity control is also available. The number of connectable indoor units with the outdoor unit is as follows. Comply with the condition as follows when installing the unit. A maximum total combination capacity of 150% and a minimum total combination capacity of 50% can be chosen by combination of the indoor units when compared with the nominal outdoor unit capacity. Therefore, the new system can meet individual air conditioning requirements in most office buildings.

Model (kBtu/h)	Min. Capacity at Individual Operation (kBtu/h)	Max. Number of Connectable I.U.	Recommended Number of Connectable I.U.	Range of Combination Capacity
AVWT-76*	05	15	8	50~150%
AVWT-96*		19	10	
AVWT-114*		22	10	
AVWT-136*		27	16	
AVWT-154*		30	16	
AVWT-170*		34	16	
AVWT-190*		38	18	
AVWT-212*		41	20	
AVWT-232*		46	26	
AVWT-250*		50	26	
AVWT-272*		54	32	
AVWT-290*		57	32	
AVWT-308*		61	32	
AVWT-326*		64	32	
AVWT-344*		64	32	
AVWT-366*		64	38	
AVWT-386*		64	38	
AVWT-402*		64	38	
AVWT-422*		64	38	
AVWT-444*		64	38	
AVWT-464*		64	38	
AVWT-482*		64	38	
AVWT-504*		64	38	
AVWT-522*		64	38	
AVWT-544*		64	38	
AVWT-556*		64	38	
AVWT-576*		64	38	
AVWT-598*		64	38	
AVWT-618*		64	38	
AVWT-634*		64	38	
AVWT-654*		64	38	
AVWT-676*		64	38	
AVWT-696*		64	38	
AVWT-714*		64	38	
AVWT-732*		64	38	
AVWT-754*		64	38	
AVWT-776*	64	38		
AVWT-794*	64	38		
AVWT-816*	64	38		
AVWT-824*	64	38		
AVWT-844*	64	38		

Model (kBtu/h)	Min. Capacity at Individual Operation (kBtu/h)	Max. Number of Connectable I.U.	Recommended Number of Connectable I.U.	Range of Combination Capacity
AVWT-866*	05	64	38	50~150%
AVWT-886*		64	38	
AVWT-908*		64	38	
AVWT-928*		64	38	
AVWT-946*		64	38	
AVWT-968*		64	38	
AVWT-986*		64	38	
AVWT-1008*		64	38	
AVWT-1026*		64	38	
AVWT-1048*		64	38	
AVWT-1066*		64	38	
AVWT-1088*		64	38	

NOTES:

- (1) In a system where all indoor units operate at the same time, total of these indoor units should not be larger than combined capacity of the outdoor units, or otherwise overload may occur under severe working condition or within narrow operating range.
- (2) For the system which all indoor units are not operated simultaneously, the total indoor unit capacity is available up to 150% against the outdoor unit capacity.
- (3) If the system is used in the cold area (ambient temperature becomes under -10°C) or under the high heating load conditions, the total indoor unit capacity should be less than 100% against the outdoor unit and total piping length is less than 300m.
- (4) 05/07 type indoor units are set with higher air flow. Determine the usage environment and installation location carefully. Do not install these units in the place where the cold draft may occur during heating operation. If the unit is installed in such places, the number of connectable I.U. should be less than the recommended number on the table above.
- (5) When the connected indoor units contain Cassette Type or Wall-Mounted Type, and the nominal capacity is less than or equal to 12kBtu/h, the total indoor unit capacity should be equal to or less than 130% against the outdoor unit.
- (6) When the outdoor air temperature is more than 43°C during the cooling operation, the total indoor unit capacity should be equal to or less than 100% against the outdoor unit.
- (7) If the operational capacity of indoor units is more than 130% against the outdoor unit, the indoor units should be set to low airflow operation.

2. General Data

2.1 General Data

Capacity(HP)			8	10	12	14	
Model			AVWT-76HKFXE	AVWT-96HKFXE	AVWT-114HKFXE	AVWT-136HKFXE	
Combination			—	—	—	—	
			—	—	—	—	
			—	—	—	—	
			—	—	—	—	
Power Supply		V/Ph/Hz	380-415V 3N~50/60Hz	380-415V 3N~50/60Hz	380-415V 3N~50/60Hz	380-415V 3N~50/60Hz	
Cooling Operation	Nominal Capacity	kW	22.4	28.0	33.5	40.0	
		Btu/h	76400	95500	114300	136500	
	Power Consumption	kW	5.46	7.09	9.18	11.32	
	EER	W/W	4.10	3.95	3.65	3.53	
Heating Operation	Capacity(MAX)	kW	25.0	31.5	37.5	45.0	
		Btu/h	85300	107500	128000	153500	
	Power Consumption(MAX)	kW	5.57	7.35	9.21	11.21	
	COP(MAX)	W/W	4.49	4.29	4.07	4.01	
	Capacity(NOM)	kW	22.4	28.0	33.5	40.0	
		Btu/h	76400	95500	114300	136500	
	Power Consumption(NOM)	kW	4.86	6.34	8.16	9.75	
COP(NOM)	W/W	4.61	4.42	4.11	4.10		
"Sound Pressure Level"※1	Normal mode	dB(A)	56	57	59	59	
	Silent mode	dB(A)	41	42	44	44	
Cabinet Color※2			White	White	White	White	
Outer Dimensions	Height×Width×Depth	mm	1730×950×750	1730×950×750	1730×950×750	1730×1210×750	
	Packing Dimensions	mm	1950×1015×790	1950×1015×790	1950×1015×790	1950×1275×790	
Net Weight		kg	204	206	213	258	
Gross Weight		kg	228	230	236	283	
Refrigerating Installation	Compressor		—	Twin Rotary	Twin Rotary	Twin Rotary	Twin Rotary
	Compressor Quantity		Set	1	1	1	1
	Refrigeration Oil	Type	—	FVC68D	FVC68D	FVC68D	FVC68D
		Brand	—	Idemitsu Kosan	Idemitsu Kosan	Idemitsu Kosan	Idemitsu Kosan
		Charge(Total)	L	4.45	4.45	4.50	6.40
	Refrigerant Charge Before Shipment		kg	5.30	5.30	5.80	8.10
	Refrigerant Flow Control		—	Micro-computer Control Expansion Valve	Micro-computer Control Expansion Valve	Micro-computer Control Expansion Valve	Micro-computer Control Expansion Valve
	Heat exchanger type		—	Multi-way cross-flow finned tube type	Multi-way cross-flow finned tube type	Multi-way cross-flow finned tube type	Multi-way cross-flow finned tube type
	Gas Pipe		mm	19.05	22.2	25.4	25.4
	Liquid Pipe		mm	9.53	9.53	12.7	12.7
Fan	Condenser Fan Quantity		—	1	1	1	2
	Air Flow Rate		m ³ /min	170	175	183	205
Hole for Power Supply Wiring		mm	46	46	46	46	
Hole for Control Line Wiring		mm	20	20	20	20	

Notes:

The above cooling and heating capacities show the capacities when the outdoor unit is operated with the 100% rating of indoor units.

Cooling Operation Conditions

Heating Operation Conditions

Indoor Air Inlet Temperature: 27°C DB (80°F DB)
19°C WB (66°F WB)

Indoor Air Inlet Temperature: 20°C DB / (68°F DB)
Outdoor Air Inlet Temperature: 7°C DB / (45°F DB)

Outdoor Air Inlet Temperature: 35°C DB (95°F DB)

6°C WB / (43°F WB)

Piping Length: 7.5 meters, Piping Lift: 0 meter

※1.The above noise values are measured in the anechoic chamber without reflected echo, therefore the impact of the reflected echo must be included at the scene.

Measurement point: 1 meter from the service cover surface and 1.5 meters from floor level.

※2.The final appearance of outdoor units is subject to the actual products.

Capacity(HP)			16	18	20	22	
Model			AVWT-154HKFXE	AVWT-170HKFXE	AVWT-190HKFXE	AVWT-212HKFXE	
Combination			—	—	—	—	
			—	—	—	—	
			—	—	—	—	
			—	—	—	—	
Power Supply		V/Ph/Hz	380-415V 3N~50/60Hz	380-415V 3N~50/60Hz	380-415V 3N~50/60Hz	380-415V 3N~50/60Hz	
Cooling Operation	Nominal Capacity	kW	45.0	50.4	56.0	61.5	
		Btu/h	153500	172000	191100	209800	
	Power Consumption	kW	13.10	15.34	17.13	18.96	
	EER	W/W	3.44	3.29	3.27	3.24	
Heating Operation	Capacity(MAX)	kW	50.0	52.5	63.0	69.0	
		Btu/h	170600	179100	215000	235400	
	Power Consumption(MAX)	kW	12.99	13.78	16.56	18.25	
	COP(MAX)	W/W	3.85	3.81	3.80	3.78	
	Capacity(NOM)	kW	45.0	50.4	56.0	61.5	
		Btu/h	153500	172000	191100	209800	
Power Consumption(NOM)	kW	11.52	12.21	14.13	16.15		
COP(NOM)	W/W	3.91	4.13	3.96	3.81		
"Sound Pressure Level"※1	Normal mode	dB(A)	60	61	62	63	
	Silent mode	dB(A)	45	46	47	48	
Cabinet Color※2			White	White	White	White	
Outer Dimensions	Height×Width×Depth	mm	1730×1210×750	1730×1210×750	1730×1350×750	1730×1350×750	
	Packing Dimensions	Height×Width×Depth	mm	1950×1275×790	1950×1275×790	1950×1420×790	1950×1420×790
Net Weight		kg	259	279	332	348	
Gross Weight		kg	284	305	362	377	
Refrigerating Installation	Compressor		—	Twin Rotary	Twin Rotary	Twin Rotary	Twin Rotary
	Compressor Quantity		Set	1	1	2	2
	Refrigeration Oil	Type	—	FVC68D	FVC68D	FVC68D	FVC68D
		Brand	—	Idemitsu Kosan	Idemitsu Kosan	Idemitsu Kosan	Idemitsu Kosan
		Charge(Total)	L	6.40	6.40	9.50	8.00
	Refrigerant Charge Before Shipment		kg	8.10	10.20	10.90	11.40
	Refrigerant Flow Control		—	Micro-computer Control Expansion Valve	Micro-computer Control Expansion Valve	Micro-computer Control Expansion Valve	Micro-computer Control Expansion Valve
	Heat exchanger type		—	Multi-way cross-flow finned tube type	Multi-way cross-flow finned tube type	Multi-way cross-flow finned tube type	Multi-way cross-flow finned tube type
	Gas Pipe		mm	28.6	28.6	28.6	28.6
	Liquid Pipe		mm	12.7	15.88	15.88	15.88
Fan	Condenser Fan Quantity		—	2	2	2	2
	Air Flow Rate		m ³ /min	210	215	267	296
Hole for Power Supply Wiring		mm	46	46	46	46	
Hole for Control Line Wiring		mm	20	20	20	20	

Notes:

The above cooling and heating capacities show the capacities when the outdoor unit is operated with the 100% rating of indoor units,

Cooling Operation Conditions

Heating Operation Conditions

Indoor Air Inlet Temperature: 27°C DB (80°F DB)

Indoor Air Inlet Temperature: 20°C DB / (68°F DB)

19°C WB (66°F WB)

Outdoor Air Inlet Temperature: 7°C DB / (45°F DB)

Outdoor Air Inlet Temperature: 35°C DB (95°F DB)

6°C WB / (43°F WB)

Piping Length: 7.5 meters, Piping Lift: 0 meter

※1.The above noise values are measured in the anechoic chamber without reflected echo, therefore the impact of the reflected echo must be included at the scene.

Measurement point: 1 meter from the service cover surface and 1.5 meters from floor level.

※2.The final appearance of outdoor units is subject to the actual products.

Capacity(HP)			24	26	28	30	
Model			AVWT-232HKFXE	AVWT-250HKFXE	AVWT-272HKFXE	AVWT-290HKFXE	
Combination			—	—	—	AVWT-154HKFXE	
			—	—	—	AVWT-136HKFXE	
			—	—	—	—	
			—	—	—	—	
Power Supply		V/Ph/Hz	380-415V 3N~50/60Hz	380-415V 3N~50/60Hz	380-415V 3N~50/60Hz	380-415V 3N~50/60Hz	
Cooling Operation	Nominal Capacity	kW	68.0	73.5	80.0	85.0	
		Btu/h	232000	250800	273000	290000	
	Power Consumption	kW	21.05	22.78	25.03	24.4	
	EER	W/W	3.23	3.23	3.20	3.48	
Heating Operation	Capacity(MAX)	kW	75.0	82.5	87.5	95.0	
		Btu/h	255900	281500	298600	324100	
	Power Consumption(MAX)	kW	19.84	22.14	23.87	24.2	
	COP(MAX)	W/W	3.78	3.73	3.67	3.93	
	Capacity(NOM)	kW	68.0	73.5	80.0	85.0	
		Btu/h	232000	250800	273000	290000	
Power Consumption(NOM)	kW	17.66	19.43	21.42	21.3		
COP(NOM)	W/W	3.85	3.78	3.73	4.00		
"Sound Pressure Level"※1	Normal mode	dB(A)	63	64	64	64	
	Silent mode	dB(A)	48	49	49	49	
Cabinet Color※2		—	White	White	White	White	
Outer Dimensions	Height×Width×Depth	mm	1730×1350×750	1730×1600×750	1730×1600×750	1730×2420×750	
	Packing Dimensions	Height×Width×Depth	mm	1950×1420×790	1950×1670×790	1950×1670×790	1950×2550×790
Net Weight		kg	349	358	369	517	
Gross Weight		kg	378	399	400	567	
Refrigerating Installation	Compressor		—	Twin Rotary	Twin Rotary	Twin Rotary	Twin Rotary
	Compressor Quantity		Set	2	2	2	2
	Refrigeration Oil	Type	—	FVC68D	FVC68D	FVC68D	FVC68D
		Brand	—	Idemitsu Kosan	Idemitsu Kosan	Idemitsu Kosan	Idemitsu Kosan
		Charge(Total)	L	8.00	8.50	8.50	12.8
	Refrigerant Charge Before Shipment		kg	11.40	11.40	11.40	16.2
	Refrigerant Flow Control		—	Micro-computer Control Expansion Valve	Micro-computer Control Expansion Valve	Micro-computer Control Expansion Valve	Micro-computer Control Expansion Valve
	Heat exchanger type		—	Multi-way cross-flow finned tube type	Multi-way cross-flow finned tube type	Multi-way cross-flow finned tube type	Multi-way cross-flow finned tube type
	Gas Pipe		mm	28.6	31.75	31.75	31.75
	Liquid Pipe		mm	15.88	19.05	19.05	19.05
Fan	Condenser Fan Quantity		—	2	2	2	4
	Air Flow Rate		m ³ /min	296	350	350	415
Hole for Power Supply Wiring		mm	46	46	46	46	
Hole for Control Line Wiring		mm	20	20	20	20	

Notes:

The above cooling and heating capacities show the capacities when the outdoor unit is operated with the 100% rating of indoor units,

Cooling Operation Conditions

Heating Operation Conditions

Indoor Air Inlet Temperature: 27°C DB (80°F DB)

Indoor Air Inlet Temperature: 20°C DB / (68°F DB)

19°C WB (66°F WB)

Outdoor Air Inlet Temperature: 7°C DB / (45°F DB)

Outdoor Air Inlet Temperature: 35°C DB (95°F DB)

6°C WB / (43°F WB)

Piping Length: 7.5 meters, Piping Lift: 0 meter

※1.The above noise values are measured in the anechoic chamber without reflected echo, therefore the impact of the reflected echo must be included at the scene.

Measurement point: 1 meter from the service cover surface and 1.5 meters from floor level.

※2.The final appearance of outdoor units is subject to the actual products.

Capacity(HP)			32	34	36	38	
Model			AVWT-308HKFXE	AVWT-326HKFXE	AVWT-344HKFXE	AVWT-366HKFXE	
Combination			AVWT-154HKFXE	AVWT-190HKFXE	AVWT-190HKFXE	AVWT-212HKFXE	
			AVWT-154HKFXE	AVWT-136HKFXE	AVWT-154HKFXE	AVWT-154HKFXE	
			—	—	—	—	
Power Supply		V/Ph/Hz	380-415V 3N~50/60Hz	380-415V 3N~50/60Hz	380-415V 3N~50/60Hz	380-415V 3N~50/60Hz	
Cooling Operation	Nominal Capacity	kW	90.0	96.0	101.0	106.5	
		Btu/h	307000	327600	344600	363300	
	Power Consumption	kW	26.2	28.5	30.2	32.1	
	EER	W/W	3.44	3.37	3.34	3.32	
Heating Operation	Capacity(MAX)	kW	100.0	108.0	113.0	119.0	
		Btu/h	341200	368500	385600	406000	
	Power Consumption(MAX)	kW	26.0	27.8	29.6	31.2	
	COP(MAX)	W/W	3.85	3.89	3.82	3.81	
	Capacity(NOM)	kW	90.0	96.0	101.0	106.5	
		Btu/h	307000	327600	344600	363300	
Power Consumption(NOM)	kW	23.0	23.9	25.7	27.7		
COP(NOM)	W/W	3.91	4.02	3.94	3.85		
"Sound Pressure Level"※1	Normal mode	dB(A)	64	64	64	65	
	Silent mode	dB(A)	49	49	49	50	
Cabinet Color※2		—	White	White	White	White	
Outer Dimensions	Height×Width×Depth	mm	1730×2420×750	1730×2560×750	1730×2560×750	1730×2560×750	
	Packing Dimensions	Height×Width×Depth	mm	1950×2550×790	1950×2695×790	1950×2695×790	1950×2695×790
Net Weight		kg	518	590	591	607	
Gross Weight		kg	568	645	646	661	
Refrigerating Installation	Compressor		—	Twin Rotary	Twin Rotary	Twin Rotary	Twin Rotary
	Compressor Quantity		Set	2	3	3	3
	Refrigeration Oil	Type	—	FVC68D	FVC68D	FVC68D	FVC68D
		Brand	—	Idemitsu Kosan	Idemitsu Kosan	Idemitsu Kosan	Idemitsu Kosan
		Charge(Total)	L	12.8	15.9	15.9	14.4
	Refrigerant Charge Before Shipment		kg	16.2	19	19	19.5
	Refrigerant Flow Control		—	Micro-computer Control Expansion Valve	Micro-computer Control Expansion Valve	Micro-computer Control Expansion Valve	Micro-computer Control Expansion Valve
	Heat exchanger type		—	Multi-way cross-flow finned tube type	Multi-way cross-flow finned tube type	Multi-way cross-flow finned tube type	Multi-way cross-flow finned tube type
	Gas Pipe		mm	31.75	38.1	38.1	38.1
Liquid Pipe		mm	19.05	19.05	19.05	19.05	
Fan	Condenser Fan Quantity		—	4	4	4	4
	Air Flow Rate		m ³ /min	420	472	477	506
Hole for Power Supply Wiring		mm	46	46	46	46	
Hole for Control Line Wiring		mm	20	20	20	20	

Notes:

The above cooling and heating capacities show the capacities when the outdoor unit is operated with the 100% rating of indoor units,

Cooling Operation Conditions

Heating Operation Conditions

Indoor Air Inlet Temperature: 27°C DB (80°F DB)

Indoor Air Inlet Temperature: 20°C DB / (68°F DB)

19°C WB (66°F WB)

Outdoor Air Inlet Temperature: 7°C DB / (45°F DB)

Outdoor Air Inlet Temperature: 35°C DB (95°F DB)

6°C WB / (43°F WB)

Piping Length: 7.5 meters, Piping Lift: 0 meter

※1.The above noise values are measured in the anechoic chamber without reflected echo, therefore the impact of the reflected echo must be included at the scene.

Measurement point: 1 meter from the service cover surface and 1.5 meters from floor level.

※2.The final appearance of outdoor units is subject to the actual products.

Capacity(HP)			40	42	44	46	
Model			AVWT-386HKFXE	AVWT-402HKFXE	AVWT-422HKFXE	AVWT-444HKFXE	
Combination			AVWT-232HKFXE	AVWT-212HKFXE	AVWT-232HKFXE	AVWT-232HKFXE	
			AVWT-154HKFXE	AVWT-190HKFXE	AVWT-190HKFXE	AVWT-212HKFXE	
			—	—	—	—	
Power Supply		V/Ph/Hz	380-415V 3N~50/60Hz	380-415V 3N~50/60Hz	380-415V 3N~50/60Hz	380-415V 3N~50/60Hz	
Cooling Operation	Nominal Capacity	kW	113.0	117.5	124.0	129.5	
		Btu/h	385500	400900	423100	441800	
	Power Consumption	kW	34.2	36.1	38.2	40.0	
	EER	W/W	3.31	3.26	3.25	3.24	
Heating Operation	Capacity(MAX)	kW	125.0	132.0	138.0	144.0	
		Btu/h	426500	450400	470900	491300	
	Power Consumption(MAX)	kW	32.8	34.8	36.4	38.1	
	COP(MAX)	W/W	3.81	3.79	3.79	3.78	
	Capacity(NOM)	kW	113.0	117.5	124.0	129.5	
		Btu/h	385500	400900	423100	441800	
Power Consumption(NOM)	kW	29.2	30.3	31.8	33.8		
	COP(NOM)	W/W	3.87	3.88	3.90	3.83	
"Sound Pressure Level"※1	Normal mode	dB(A)	65	65	66	66	
	Silent mode	dB(A)	50	50	51	51	
Cabinet Color※2			White	White	White	White	
Outer Dimensions	Height×Width×Depth	mm	1730×2560×750	1730×2700×750	1730×2700×750	1730×2700×750	
	Packing Dimensions	Height×Width×Depth	mm	1950×2695×790	1950×2840×790	1950×2840×790	1950×2840×790
Net Weight		kg	608	680	681	697	
Gross Weight		kg	662	739	740	755	
Refrigerating Installation	Compressor		—	Twin Rotary	Twin Rotary	Twin Rotary	Twin Rotary
	Compressor Quantity		Set	3	4	4	4
	Refrigeration Oil	Type	—	FVC68D	FVC68D	FVC68D	FVC68D
		Brand	—	Idemitsu Kosan	Idemitsu Kosan	Idemitsu Kosan	Idemitsu Kosan
		Charge(Total)	L	14.4	17.5	17.5	16
	Refrigerant Charge Before Shipment		kg	19.5	22.3	22.3	22.8
	Refrigerant Flow Control		—	Micro-computer Control Expansion Valve	Micro-computer Control Expansion Valve	Micro-computer Control Expansion Valve	Micro-computer Control Expansion Valve
	Heat exchanger type		—	Multi-way cross-flow finned tube type	Multi-way cross-flow finned tube type	Multi-way cross-flow finned tube type	Multi-way cross-flow finned tube type
	Gas Pipe		mm	38.1	38.1	38.1	41.3
Liquid Pipe		mm	19.05	19.05	19.05	22.2	
Fan	Condenser Fan Quantity		—	4	4	4	4
	Air Flow Rate		m ³ /min	506	563	563	592
Hole for Power Supply Wiring		mm	46	46	46	46	
Hole for Control Line Wiring		mm	20	20	20	20	

Notes:

The above cooling and heating capacities show the capacities when the outdoor unit is operated with the 100% rating of indoor units,

Cooling Operation Conditions

Heating Operation Conditions

Indoor Air Inlet Temperature: 27°C DB (80°F DB)

Indoor Air Inlet Temperature: 20°C DB / (68°F DB)

19°C WB (66°F WB)

Outdoor Air Inlet Temperature: 7°C DB / (45°F DB)

Outdoor Air Inlet Temperature: 35°C DB (95°F DB)

6°C WB / (43°F WB)

Piping Length: 7.5 meters, Piping Lift: 0 meter

※1.The above noise values are measured in the anechoic chamber without reflected echo, therefore the impact of the reflected echo must be included at the scene.

Measurement point: 1 meter from the service cover surface and 1.5 meters from floor level.

※2.The final appearance of outdoor units is subject to the actual products.

Capacity(HP)			48	50	52	54	
Model			AVWT-464HKFXE	AVWT-482HKFXE	AVWT-504HKFXE	AVWT-522HKFXE	
Combination			AVWT-232HKFXE	AVWT-250HKFXE	AVWT-272HKFXE	AVWT-272HKFXE	
			AVWT-232HKFXE	AVWT-232HKFXE	AVWT-232HKFXE	AVWT-250HKFXE	
			—	—	—	—	
Power Supply		V/Ph/Hz	380-415V 3N~50/60Hz	380-415V 3N~50/60Hz	380-415V 3N~50/60Hz	380-415V 3N~50/60Hz	
Cooling Operation	Nominal Capacity	kW	136.0	141.5	148.0	153.5	
		Btu/h	464000	482800	505000	523800	
	Power Consumption	kW	42.1	43.8	46.1	47.8	
	EER	W/W	3.23	3.23	3.21	3.21	
Heating Operation	Capacity(MAX)	kW	150.0	157.5	162.5	170.0	
		Btu/h	511800	537400	554500	580100	
	Power Consumption(MAX)	kW	39.7	42.0	43.7	46.0	
	COP(MAX)	W/W	3.78	3.75	3.72	3.69	
	Capacity(NOM)	kW	136.0	141.5	148.0	153.5	
		Btu/h	464000	482800	505000	523800	
Power Consumption(NOM)	kW	35.3	37.1	39.1	40.9		
COP(NOM)	W/W	3.85	3.82	3.79	3.76		
"Sound Pressure Level"※1	Normal mode	dB(A)	66	67	67	67	
	Silent mode	dB(A)	51	52	52	52	
Cabinet Color※2			White	White	White	White	
Outer Dimensions	Height×Width×Depth	mm	1730×2700×750	1730×2950×750	1730×2950×750	1730×3200×750	
	Packing Dimensions	Height×Width×Depth	mm	1950×2840×790	1950×3090×790	1950×3090×790	1950×3340×790
Net Weight		kg	698	707	718	727	
Gross Weight		kg	756	777	778	799	
Refrigerating Installation	Compressor		—	Twin Rotary	Twin Rotary	Twin Rotary	Twin Rotary
	Compressor Quantity		Set	4	4	4	4
	Refrigeration Oil	Type	—	FVC68D	FVC68D	FVC68D	FVC68D
		Brand	—	Idemitsu Kosan	Idemitsu Kosan	Idemitsu Kosan	Idemitsu Kosan
		Charge(Total)	L	16	16.5	16.5	17
	Refrigerant Charge Before Shipment		kg	22.8	22.8	22.8	22.8
	Refrigerant Flow Control		—	Micro-computer Control Expansion Valve	Micro-computer Control Expansion Valve	Micro-computer Control Expansion Valve	Micro-computer Control Expansion Valve
	Heat exchanger type		—	Multi-way cross-flow finned tube type	Multi-way cross-flow finned tube type	Multi-way cross-flow finned tube type	Multi-way cross-flow finned tube type
	Gas Pipe		mm	41.3	41.3	41.3	41.3
Liquid Pipe		mm	22.2	22.2	22.2	22.2	
Fan	Condenser Fan Quantity		—	4	4	4	4
	Air Flow Rate		m ³ /min	592	646	646	700
Hole for Power Supply Wiring		mm	46	46	46	46	
Hole for Control Line Wiring		mm	20	20	20	20	

Notes:

The above cooling and heating capacities show the capacities when the outdoor unit is operated with the 100% rating of indoor units,

Cooling Operation Conditions

Heating Operation Conditions

Indoor Air Inlet Temperature: 27°C DB (80°F DB)

Indoor Air Inlet Temperature: 20°C DB / (68°F DB)

19°C WB (66°F WB)

Outdoor Air Inlet Temperature: 7°C DB / (45°F DB)

Outdoor Air Inlet Temperature: 35°C DB (95°F DB)

6°C WB / (43°F WB)

Piping Length: 7.5 meters, Piping Lift: 0 meter

※1.The above noise values are measured in the anechoic chamber without reflected echo, therefore the impact of the reflected echo must be included at the scene.

Measurement point: 1 meter from the service cover surface and 1.5 meters from floor level.

※2.The final appearance of outdoor units is subject to the actual products.

Capacity(HP)			56	58	60	62	
Model			AVWT-544HKFXE	AVWT-556HKFXE	AVWT-576HKFXE	AVWT-598HKFXE	
Combination			AVWT-272HKFXE	AVWT-212HKFXE	AVWT-232HKFXE	AVWT-232HKFXE	
			AVWT-272HKFXE	AVWT-190HKFXE	AVWT-190HKFXE	AVWT-212HKFXE	
			—	AVWT-154HKFXE	AVWT-154HKFXE	AVWT-154HKFXE	
Power Supply		V/Ph/Hz	380-415V 3N~50/60Hz	380-415V 3N~50/60Hz	380-415V 3N~50/60Hz	380-415V 3N~50/60Hz	
Cooling Operation	Nominal Capacity	kW	160.0	162.5	169.0	174.5	
		Btu/h	546000	554400	576600	595300	
	Power Consumption	kW	50.1	49.2	51.3	53.1	
	EER	W/W	3.20	3.30	3.30	3.29	
Heating Operation	Capacity(MAX)	kW	175.0	182.0	188.0	194.0	
		Btu/h	597200	621000	641500	661900	
	Power Consumption(MAX)	kW	47.7	47.8	49.4	51.1	
	COP(MAX)	W/W	3.67	3.81	3.81	3.80	
	Capacity(NOM)	kW	160.0	162.5	169.0	174.5	
		Btu/h	546000	554400	576600	595300	
Power Consumption(NOM)	kW	42.8	41.8	43.3	45.3		
	COP(NOM)	W/W	3.73	3.89	3.90	3.85	
"Sound Pressure Level"※1	Normal mode	dB(A)	67	67	67	67	
	Silent mode	dB(A)	52	52	52	52	
Cabinet Color※2			White	White	White	White	
Outer Dimensions	Height×Width×Depth	mm	1730×3200×750	1730×3910×750	1730×3910×750	1730×3910×750	
	Packing Dimensions	Height×Width×Depth	mm	1950×3340×790	1950×4115×790	1950×4115×790	1950×4115×790
Net Weight		kg	738	939	940	956	
Gross Weight		kg	800	1023	1024	1039	
Refrigerating Installation	Compressor		—	Twin Rotary	Twin Rotary	Twin Rotary	Twin Rotary
	Compressor Quantity		Set	4	5	5	5
	Refrigeration Oil	Type	—	FVC68D	FVC68D	FVC68D	FVC68D
		Brand	—	Idemitsu Kosan	Idemitsu Kosan	Idemitsu Kosan	Idemitsu Kosan
		Charge(Total)	L	17	23.9	23.9	22.4
	Refrigerant Charge Before Shipment		kg	22.8	30.4	30.4	30.9
	Refrigerant Flow Control		—	Micro-computer Control Expansion Valve	Micro-computer Control Expansion Valve	Micro-computer Control Expansion Valve	Micro-computer Control Expansion Valve
	Heat exchanger type		—	Multi-way cross-flow finned tube type	Multi-way cross-flow finned tube type	Multi-way cross-flow finned tube type	Multi-way cross-flow finned tube type
	Gas Pipe		mm	41.3	44.5	44.5	44.5
Liquid Pipe		mm	22.2	22.2	22.2	22.2	
Fan	Condenser Fan Quantity		—	4	6	6	6
	Air Flow Rate		m ³ /min	700	773	773	802
Hole for Power Supply Wiring		mm	46	46	46	46	
Hole for Control Line Wiring		mm	20	20	20	20	

Notes:

The above cooling and heating capacities show the capacities when the outdoor unit is operated with the 100% rating of indoor units,

Cooling Operation Conditions

Heating Operation Conditions

Indoor Air Inlet Temperature: 27°C DB (80°F DB)

Indoor Air Inlet Temperature: 20°C DB / (68°F DB)

19°C WB (66°F WB)

Outdoor Air Inlet Temperature: 7°C DB / (45°F DB)

Outdoor Air Inlet Temperature: 35°C DB (95°F DB)

6°C WB / (43°F WB)

Piping Length: 7.5 meters, Piping Lift: 0 meter

※1.The above noise values are measured in the anechoic chamber without reflected echo, therefore the impact of the reflected echo must be included at the scene.

Measurement point: 1 meter from the service cover surface and 1.5 meters from floor level.

※2.The final appearance of outdoor units is subject to the actual products.

Capacity(HP)			64	66	68	70	
Model			AVWT-618HKFXE	AVWT-634HKFXE	AVWT-654HKFXE	AVWT-676HKFXE	
Combination			AVWT-232HKFXE	AVWT-232HKFXE	AVWT-232HKFXE	AVWT-232HKFXE	
			AVWT-232HKFXE	AVWT-212HKFXE	AVWT-232HKFXE	AVWT-232HKFXE	
			AVWT-154HKFXE	AVWT-190HKFXE	AVWT-190HKFXE	AVWT-212HKFXE	
Power Supply		V/Ph/Hz	380-415V 3N~50/60Hz	380-415V 3N~50/60Hz	380-415V 3N~50/60Hz	380-415V 3N~50/60Hz	
Cooling Operation	Nominal Capacity	kW	181.0	185.5	192.0	197.5	
		Btu/h	617500	632900	655100	673800	
	Power Consumption	kW	55.2	57.1	59.2	61.1	
	EER	W/W	3.28	3.25	3.24	3.23	
Heating Operation	Capacity(MAX)	kW	200.0	207.0	213.0	219.0	
		Btu/h	682400	706300	726800	747200	
	Power Consumption(MAX)	kW	52.7	54.7	56.2	57.9	
	COP(MAX)	W/W	3.80	3.79	3.79	3.78	
	Capacity(NOM)	kW	181.0	185.5	192.0	197.5	
		Btu/h	617500	632900	655100	673800	
Power Consumption(NOM)	kW	46.8	47.9	49.5	51.5		
COP(NOM)	W/W	3.86	3.87	3.88	3.84		
"Sound Pressure Level"※1	Normal mode	dB(A)	67	67	67	68	
	Silent mode	dB(A)	52	52	52	53	
Cabinet Color※2		—	White	White	White	White	
Outer Dimensions	Height×Width×Depth	mm	1730×3910×750	1730×4050×750	1730×4050×750	1730×4050×750	
	Packing Dimensions	mm	1950×4115×790	1950×4260×790	1950×4260×790	1950×4260×790	
Net Weight		kg	957	1029	1030	1046	
Gross Weight		kg	1040	1117	1118	1133	
Refrigerating Installation	Compressor		—	Twin Rotary	Twin Rotary	Twin Rotary	Twin Rotary
	Compressor Quantity		Set	5	6	6	6
	Refrigeration Oil	Type	—	FVC68D	FVC68D	FVC68D	FVC68D
		Brand	—	Idemitsu Kosan	Idemitsu Kosan	Idemitsu Kosan	Idemitsu Kosan
		Charge(Total)	L	22.4	25.5	25.5	24
	Refrigerant Charge Before Shipment		kg	30.9	33.7	33.7	34.2
	Refrigerant Flow Control		—	Micro-computer Control Expansion Valve	Micro-computer Control Expansion Valve	Micro-computer Control Expansion Valve	Micro-computer Control Expansion Valve
	Heat exchanger type		—	Multi-way cross-flow finned tube type	Multi-way cross-flow finned tube type	Multi-way cross-flow finned tube type	Multi-way cross-flow finned tube type
	Gas Pipe		mm	44.5	44.5	50.8	50.8
Liquid Pipe		mm	22.2	22.2	25.4	25.4	
Fan	Condenser Fan Quantity		—	6	6	6	6
	Air Flow Rate		m ³ /min	802	859	859	888
Hole for Power Supply Wiring		mm	46	46	46	46	
Hole for Control Line Wiring		mm	20	20	20	20	

Notes:

The above cooling and heating capacities show the capacities when the outdoor unit is operated with the 100% rating of indoor units,

Cooling Operation Conditions

Heating Operation Conditions

Indoor Air Inlet Temperature: 27°C DB (80°F DB)

Indoor Air Inlet Temperature: 20°C DB / (68°F DB)

19°C WB (66°F WB)

Outdoor Air Inlet Temperature: 7°C DB / (45°F DB)

Outdoor Air Inlet Temperature: 35°C DB (95°F DB)

6°C WB / (43°F WB)

Piping Length: 7.5 meters, Piping Lift: 0 meter

※1.The above noise values are measured in the anechoic chamber without reflected echo, therefore the impact of the reflected echo must be included at the scene.

Measurement point: 1 meter from the service cover surface and 1.5 meters from floor level.

※2.The final appearance of outdoor units is subject to the actual products.

Capacity(HP)			72	74	76	78	
Model			AVWT-696HKFXE	AVWT-714HKFXE	AVWT-732HKFXE	AVWT-754HKFXE	
Combination			AVWT-232HKFXE	AVWT-250HKFXE	AVWT-250HKFXE	AVWT-272HKFXE	
			AVWT-232HKFXE	AVWT-232HKFXE	AVWT-250HKFXE	AVWT-250HKFXE	
			AVWT-232HKFXE	AVWT-232HKFXE	AVWT-232HKFXE	AVWT-232HKFXE	
Power Supply		V/Ph/Hz	380-415V 3N~50/60Hz	380-415V 3N~50/60Hz	380-415V 3N~50/60Hz	380-415V 3N~50/60Hz	
Cooling Operation	Nominal Capacity	kW	204.0	209.5	215.0	221.5	
		Btu/h	696000	714800	733600	755800	
	Power Consumption	kW	63.2	64.9	66.6	68.9	
	EER	W/W	3.23	3.23	3.23	3.22	
Heating Operation	Capacity(MAX)	kW	225.0	232.5	240.0	245.0	
		Btu/h	767700	793300	818900	836000	
	Power Consumption(MAX)	kW	59.5	61.8	64.1	65.9	
	COP(MAX)	W/W	3.78	3.76	3.74	3.72	
	Capacity(NOM)	kW	204.0	209.5	215.0	221.5	
		Btu/h	696000	714800	733600	755800	
Power Consumption(NOM)	kW	53.0	54.8	56.5	58.5		
COP(NOM)	W/W	3.85	3.83	3.80	3.79		
"Sound Pressure Level"※1	Normal mode	dB(A)	68	68	68	68	
	Silent mode	dB(A)	53	53	53	53	
Cabinet Color※2		—	White	White	White	White	
Outer Dimensions	Height×Width×Depth	mm	1730×4050×750	1730×4300×750	1730×4550×750	1730×4550×750	
	Packing Dimensions	Height×Width×Depth	mm	1950×4260×790	1950×4510×790	1950×4760×790	1950×4760×790
Net Weight		kg	1047	1056	1065	1076	
Gross Weight		kg	1134	1155	1176	1177	
Refrigerating Installation	Compressor		—	Twin Rotary	Twin Rotary	Twin Rotary	Twin Rotary
	Compressor Quantity		Set	6	6	6	6
	Refrigeration Oil	Type	—	FVC68D	FVC68D	FVC68D	FVC68D
		Brand	—	Idemitsu Kosan	Idemitsu Kosan	Idemitsu Kosan	Idemitsu Kosan
		Charge(Total)	L	24	24.5	25	25
	Refrigerant Charge Before Shipment		kg	34.2	34.2	34.2	34.2
	Refrigerant Flow Control		—	Micro-computer Control Expansion Valve	Micro-computer Control Expansion Valve	Micro-computer Control Expansion Valve	Micro-computer Control Expansion Valve
	Heat exchanger type		—	Multi-way cross-flow finned tube type	Multi-way cross-flow finned tube type	Multi-way cross-flow finned tube type	Multi-way cross-flow finned tube type
	Gas Pipe		mm	50.8	50.8	50.8	50.8
Liquid Pipe		mm	25.4	25.4	25.4	25.4	
Fan	Condenser Fan Quantity		—	6	6	6	6
	Air Flow Rate		m ³ /min	888	942	996	996
Hole for Power Supply Wiring		mm	46	46	46	46	
Hole for Control Line Wiring		mm	20	20	20	20	

Notes:

The above cooling and heating capacities show the capacities when the outdoor unit is operated with the 100% rating of indoor units,

Cooling Operation Conditions

Heating Operation Conditions

Indoor Air Inlet Temperature: 27°C DB (80°F DB)

Indoor Air Inlet Temperature: 20°C DB / (68°F DB)

19°C WB (66°F WB)

Outdoor Air Inlet Temperature: 7°C DB / (45°F DB)

Outdoor Air Inlet Temperature: 35°C DB (95°F DB)

6°C WB / (43°F WB)

Piping Length: 7.5 meters, Piping Lift: 0 meter

※1.The above noise values are measured in the anechoic chamber without reflected echo, therefore the impact of the reflected echo must be included at the scene.

Measurement point: 1 meter from the service cover surface and 1.5 meters from floor level.

※2.The final appearance of outdoor units is subject to the actual products.

Capacity(HP)			80	82	84	86	
Model			AVWT-776HKFXE	AVWT-794HKFXE	AVWT-816HKFXE	AVWT-824HKFXE	
Combination			AVWT-272HKFXE	AVWT-272HKFXE	AVWT-272HKFXE	AVWT-232HKFXE	
			AVWT-272HKFXE	AVWT-272HKFXE	AVWT-272HKFXE	AVWT-212HKFXE	
			AVWT-232HKFXE	AVWT-250HKFXE	AVWT-272HKFXE	AVWT-190HKFXE	
			—	—	—	AVWT-190HKFXE	
Power Supply		V/Ph/Hz	380-415V 3N~50/60Hz	380-415V 3N~50/60Hz	380-415V 3N~50/60Hz	380-415V 3N~50/60Hz	
Cooling Operation	Nominal Capacity	kW	228.0	233.5	240.0	241.5	
		Btu/h	778000	796800	819000	824000	
	Power Consumption	kW	71.1	72.8	75.1	74.3	
	EER	W/W	3.21	3.21	3.20	3.25	
Heating Operation	Capacity(MAX)	kW	250.0	257.5	262.5	270.0	
		Btu/h	853100	878700	895800	921300	
	Power Consumption(MAX)	kW	67.6	69.9	71.6	71.2	
	COP(MAX)	W/W	3.70	3.68	3.67	3.79	
	Capacity(NOM)	kW	228.0	233.5	240.0	241.5	
		Btu/h	778000	796800	819000	824000	
Power Consumption(NOM)	kW	60.5	62.3	64.3	62.1		
	COP(NOM)	W/W	3.77	3.75	3.73	3.89	
"Sound Pressure Level"※1	Normal mode	dB(A)	68	69	69	69	
	Silent mode	dB(A)	53	54	54	54	
Cabinet Color※2		—	White	White	White	White	
Outer Dimensions	Height×Width×Depth	mm	1730×4550×750	1730×4800×750	1730×4800×750	1730×5400×750	
	Packing Dimensions	Height×Width×Depth	mm	1950×4760×790	1950×5010×790	1950×5010×790	1950×5680×790
Net Weight		kg	1087	1096	1107	1361	
Gross Weight		kg	1178	1199	1200	1479	
Refrigerating Installation	Compressor		—	Twin Rotary	Twin Rotary	Twin Rotary	Twin Rotary
	Compressor Quantity		Set	6	6	6	8
	Refrigeration Oil	Type	—	FVC68D	FVC68D	FVC68D	FVC68D
		Brand	—	Idemitsu Kosan	Idemitsu Kosan	Idemitsu Kosan	Idemitsu Kosan
		Charge(Total)	L	25	25.5	25.5	35
	Refrigerant Charge Before Shipment		kg	34.2	34.2	34.2	44.6
	Refrigerant Flow Control		—	Micro-computer Control Expansion Valve	Micro-computer Control Expansion Valve	Micro-computer Control Expansion Valve	Micro-computer Control Expansion Valve
	Heat exchanger type		—	Multi-way cross-flow finned tube type	Multi-way cross-flow finned tube type	Multi-way cross-flow finned tube type	Multi-way cross-flow finned tube type
	Gas Pipe		mm	50.8	50.8	50.8	50.8
Liquid Pipe		mm	25.4	25.4	25.4	25.4	
Fan	Condenser Fan Quantity		—	6	6	6	8
	Air Flow Rate		m ³ /min	996	1050	1050	1126
Hole for Power Supply Wiring		mm	46	46	46	46	
Hole for Control Line Wiring		mm	20	20	20	20	

Notes:

The above cooling and heating capacities show the capacities when the outdoor unit is operated with the 100% rating of indoor units,

Cooling Operation Conditions

Heating Operation Conditions

Indoor Air Inlet Temperature: 27°C DB (80°F DB)

Indoor Air Inlet Temperature: 20°C DB / (68°F DB)

19°C WB (66°F WB)

Outdoor Air Inlet Temperature: 7°C DB / (45°F DB)

Outdoor Air Inlet Temperature: 35°C DB (95°F DB)

6°C WB / (43°F WB)

Piping Length: 7.5 meters, Piping Lift: 0 meter

※1.The above noise values are measured in the anechoic chamber without reflected echo, therefore the impact of the reflected echo must be included at the scene.

Measurement point: 1 meter from the service cover surface and 1.5 meters from floor level.

※2.The final appearance of outdoor units is subject to the actual products.

Capacity(HP)			88	90	92	94	
Model			AVWT-844HKFXE	AVWT-866HKFXE	AVWT-886HKFXE	AVWT-908HKFXE	
Combination			AVWT-232HKFXE	AVWT-232HKFXE	AVWT-232HKFXE	AVWT-232HKFXE	
			AVWT-232HKFXE	AVWT-232HKFXE	AVWT-232HKFXE	AVWT-232HKFXE	
			AVWT-190HKFXE	AVWT-212HKFXE	AVWT-232HKFXE	AVWT-232HKFXE	
			AVWT-190HKFXE	AVWT-190HKFXE	AVWT-190HKFXE	AVWT-212HKFXE	
Power Supply		V/Ph/Hz	380-415V 3N~50/60Hz	380-415V 3N~50/60Hz	380-415V 3N~50/60Hz	380-415V 3N~50/60Hz	
Cooling Operation	Nominal Capacity	kW	248.0	253.5	260.0	265.5	
		Btu/h	846200	864900	887100	905800	
	Power Consumption	kW	76.4	78.2	80.3	82.1	
	EER	W/W	3.25	3.24	3.24	3.23	
Heating Operation	Capacity(MAX)	kW	276.0	282.0	288.0	294.0	
		Btu/h	941800	962200	982700	1003100	
	Power Consumption(MAX)	kW	72.8	74.5	76.1	77.8	
	COP(MAX)	W/W	3.79	3.79	3.79	3.78	
	Capacity(NOM)	kW	248.0	253.5	260.0	265.5	
		Btu/h	846200	864900	887100	905800	
Power Consumption(NOM)	kW	63.6	65.6	67.1	69.1		
COP(NOM)	W/W	3.90	3.86	3.87	3.84		
"Sound Pressure Level"※1	Normal mode	dB(A)	69	69	69	69	
	Silent mode	dB(A)	54	54	54	54	
Cabinet Color※2		—	White	White	White	White	
Outer Dimensions	Height×Width×Depth	mm	1730×5400×750	1730×5400×750	1730×5400×750	1730×5400×750	
	Packing Dimensions	mm	1950×5680×790	1950×5680×790	1950×5680×790	1950×5680×790	
Net Weight		kg	1362	1378	1379	1395	
Gross Weight		kg	1480	1495	1496	1511	
Refrigerating Installation	Compressor		—	Twin Rotary	Twin Rotary	Twin Rotary	Twin Rotary
	Compressor Quantity		Set	8	8	8	8
	Refrigeration Oil	Type	—	FVC68D	FVC68D	FVC68D	FVC68D
		Brand	—	Idemitsu Kosan	Idemitsu Kosan	Idemitsu Kosan	Idemitsu Kosan
		Charge(Total)	L	35	33.5	33.5	32
	Refrigerant Charge Before Shipment		kg	44.6	45.1	45.1	45.6
	Refrigerant Flow Control		—	Micro-computer Control Expansion Valve	Micro-computer Control Expansion Valve	Micro-computer Control Expansion Valve	Micro-computer Control Expansion Valve
	Heat exchanger type		—	Multi-way cross-flow finned tube type	Multi-way cross-flow finned tube type	Multi-way cross-flow finned tube type	Multi-way cross-flow finned tube type
	Gas Pipe		mm	50.8	50.8	50.8	50.8
	Liquid Pipe		mm	25.4	25.4	25.4	25.4
Fan	Condenser Fan Quantity		—	8	8	8	8
	Air Flow Rate		m ³ /min	1126	1155	1155	1184
Hole for Power Supply Wiring		mm	46	46	46	46	
Hole for Control Line Wiring		mm	20	20	20	20	

Notes:

The above cooling and heating capacities show the capacities when the outdoor unit is operated with the 100% rating of indoor units,

Cooling Operation Conditions

Heating Operation Conditions

Indoor Air Inlet Temperature: 27°C DB (80°F DB)

Indoor Air Inlet Temperature: 20°C DB / (68°F DB)

19°C WB (66°F WB)

Outdoor Air Inlet Temperature: 7°C DB / (45°F DB)

Outdoor Air Inlet Temperature: 35°C DB (95°F DB)

6°C WB / (43°F WB)

Piping Length: 7.5 meters, Piping Lift: 0 meter

※1.The above noise values are measured in the anechoic chamber without reflected echo, therefore the impact of the reflected echo must be included at the scene.

Measurement point: 1 meter from the service cover surface and 1.5 meters from floor level.

※2.The final appearance of outdoor units is subject to the actual products.

Capacity(HP)			96	98	100	102	
Model			AVWT-928HKFXE	AVWT-946HKFXE	AVWT-968HKFXE	AVWT-986HKFXE	
Combination			AVWT-232HKFXE	AVWT-250HKFXE	AVWT-272HKFXE	AVWT-272HKFXE	
			AVWT-232HKFXE	AVWT-232HKFXE	AVWT-232HKFXE	AVWT-250HKFXE	
			AVWT-232HKFXE	AVWT-232HKFXE	AVWT-232HKFXE	AVWT-232HKFXE	
			AVWT-232HKFXE	AVWT-232HKFXE	AVWT-232HKFXE	AVWT-232HKFXE	
Power Supply		V/Ph/Hz	380-415V 3N~50/60Hz	380-415V 3N~50/60Hz	380-415V 3N~50/60Hz	380-415V 3N~50/60Hz	
Cooling Operation	Nominal Capacity	kW	272.0	277.5	284.0	289.5	
		Btu/h	928000	946800	969000	987800	
	Power Consumption	kW	84.2	85.9	88.2	89.9	
	EER	W/W	3.23	3.23	3.22	3.22	
Heating Operation	Capacity(MAX)	kW	300.0	307.5	312.5	320.0	
		Btu/h	1023600	1049200	1066300	1091900	
	Power Consumption(MAX)	kW	79.4	81.7	83.4	85.7	
	COP(MAX)	W/W	3.78	3.77	3.75	3.73	
	Capacity(NOM)	kW	272.0	277.5	284.0	289.5	
		Btu/h	928000	946800	969000	987800	
Power Consumption(NOM)	kW	70.6	72.4	74.4	76.2		
	COP(NOM)	W/W	3.85	3.83	3.82	3.80	
"Sound Pressure Level"※1	Normal mode	dB(A)	69	69	70	70	
	Silent mode	dB(A)	54	54	55	55	
Cabinet Color※2		—	White	White	White	White	
Outer Dimensions	Height×Width×Depth	mm	1730×5400×750	1730×5650×750	1730×5650×750	1730×5900×750	
	Packing Dimensions	mm	1950×5680×790	1950×5930×790	1950×5930×790	1950×6180×790	
Net Weight		kg	1396	1405	1416	1425	
Gross Weight		kg	1512	1533	1534	1555	
Refrigerating Installation	Compressor		—	Twin Rotary	Twin Rotary	Twin Rotary	Twin Rotary
	Compressor Quantity		Set	8	8	8	8
	Refrigeration Oil	Type	—	FVC68D	FVC68D	FVC68D	FVC68D
		Brand	—	Idemitsu Kosan	Idemitsu Kosan	Idemitsu Kosan	Idemitsu Kosan
		Charge(Total)	L	32	32.5	32.5	33
	Refrigerant Charge Before Shipment		kg	45.6	45.6	45.6	45.6
	Refrigerant Flow Control		—	Micro-computer Control Expansion Valve	Micro-computer Control Expansion Valve	Micro-computer Control Expansion Valve	Micro-computer Control Expansion Valve
	Heat exchanger type		—	Multi-way cross-flow finned tube type	Multi-way cross-flow finned tube type	Multi-way cross-flow finned tube type	Multi-way cross-flow finned tube type
	Gas Pipe		mm	50.8	50.8	50.8	50.8
Liquid Pipe		mm	25.4	25.4	25.4	25.4	
Fan	Condenser Fan Quantity		—	8	8	8	8
	Air Flow Rate		m ³ /min	1184	1238	1238	1292
Hole for Power Supply Wiring		mm	46	46	46	46	
Hole for Control Line Wiring		mm	20	20	20	20	

Notes:

The above cooling and heating capacities show the capacities when the outdoor unit is operated with the 100% rating of indoor units,

Cooling Operation Conditions

Heating Operation Conditions

Indoor Air Inlet Temperature: 27°C DB (80°F DB)

Indoor Air Inlet Temperature: 20°C DB / (68°F DB)

19°C WB (66°F WB)

Outdoor Air Inlet Temperature: 7°C DB / (45°F DB)

Outdoor Air Inlet Temperature: 35°C DB (95°F DB)

6°C WB / (43°F WB)

Piping Length: 7.5 meters, Piping Lift: 0 meter

※1.The above noise values are measured in the anechoic chamber without reflected echo, therefore the impact of the reflected echo must be included at the scene.

Measurement point: 1 meter from the service cover surface and 1.5 meters from floor level.

※2.The final appearance of outdoor units is subject to the actual products.

Capacity(HP)			104	106	108	
Model			AVWT-1008HKFXE	AVWT-1026HKFXE	AVWT-1048HKFXE	
Combination			AVWT-272HKFXE	AVWT-272HKFXE	AVWT-272HKFXE	
			AVWT-272HKFXE	AVWT-272HKFXE	AVWT-272HKFXE	
			AVWT-232HKFXE	AVWT-250HKFXE	AVWT-272HKFXE	
			AVWT-232HKFXE	AVWT-232HKFXE	AVWT-232HKFXE	
Power Supply		V/Ph/Hz	380-415V 3N~50/60Hz	380-415V 3N~50/60Hz	380-415V 3N~50/60Hz	
Cooling Operation	Nominal Capacity	kW	296.0	301.5	308.0	
		Btu/h	1010000	1028800	1051000	
	Power Consumption	kW	92.2	93.9	96.1	
	EER	W/W	3.21	3.21	3.20	
Heating Operation	Capacity(MAX)	kW	325.0	332.5	337.5	
		Btu/h	1109000	1134600	1151700	
	Power Consumption(MAX)	kW	87.4	89.7	91.5	
	COP(MAX)	W/W	3.72	3.71	3.69	
	Capacity(NOM)	kW	296.0	301.5	308.0	
		Btu/h	1010000	1028800	1051000	
Power Consumption(NOM)	kW	78.2	79.9	81.9		
COP(NOM)	W/W	3.79	3.77	3.76		
"Sound Pressure Level"※1	Normal mode	dB(A)	70	70	70	
	Silent mode	dB(A)	55	55	55	
Cabinet Color※2		—	White	White	White	
Outer Dimensions	Height×Width×Depth	mm	1730×5900×750	1730×6150×750	1730×6150×750	
	Packing Dimensions	Height×Width×Depth	mm	1950×6180×790	1950×6430×790	1950×6430×790
Net Weight		kg	1436	1445	1456	
Gross Weight		kg	1556	1577	1578	
Refrigerating Installation	Compressor		—	Twin Rotary	Twin Rotary	Twin Rotary
	Compressor Quantity		Set	8	8	8
	Refrigeration Oil	Type	—	FVC68D	FVC68D	FVC68D
		Brand	—	Idemitsu Kosan	Idemitsu Kosan	Idemitsu Kosan
		Charge(Total)	L	33	33.5	33.5
	Refrigerant Charge Before Shipment		kg	45.6	45.6	45.6
	Refrigerant Flow Control		—	Micro-computer Control Expansion Valve	Micro-computer Control Expansion Valve	Micro-computer Control Expansion Valve
	Heat exchanger type		—	Multi-way cross-flow finned tube type	Multi-way cross-flow finned tube type	Multi-way cross-flow finned tube type
	Gas Pipe		mm	50.8	50.8	50.8
	Liquid Pipe		mm	25.4	25.4	25.4
Fan	Condenser Fan Quantity		—	8	8	8
	Air Flow Rate		m ³ /min	1292	1346	1346
Hole for Power Supply Wiring		mm	46	46	46	
Hole for Control Line Wiring		mm	20	20	20	

Notes:

The above cooling and heating capacities show the capacities when the outdoor unit is operated with the 100% rating of indoor units,

Cooling Operation Conditions

Heating Operation Conditions

Indoor Air Inlet Temperature: 27°C DB (80°F DB)

Indoor Air Inlet Temperature: 20°C DB / (68°F DB)

19°C WB (66°F WB)

Outdoor Air Inlet Temperature: 7°C DB / (45°F DB)

Outdoor Air Inlet Temperature: 35°C DB (95°F DB)

6°C WB / (43°F WB)

Piping Length: 7.5 meters, Piping Lift: 0 meter

※1.The above noise values are measured in the anechoic chamber without reflected echo, therefore the impact of the reflected echo must be included at the scene.

Measurement point: 1 meter from the service cover surface and 1.5 meters from floor level.

※2.The final appearance of outdoor units is subject to the actual products.

Capacity(HP)			110	112	
Model			AVWT-1066HKFXE	AVWT-1088HKFXE	
Combination			AVWT-272HKFXE	AVWT-272HKFXE	
			AVWT-272HKFXE	AVWT-272HKFXE	
			AVWT-272HKFXE	AVWT-272HKFXE	
			AVWT-250HKFXE	AVWT-272HKFXE	
Power Supply		V/Ph/Hz	380-415V 3N~50/60Hz	380-415V 3N~50/60Hz	
Cooling Operation	Nominal Capacity	kW	313.5	320.0	
		Btu/h	1069800	1092000	
	Power Consumption	kW	97.9	100.1	
	EER	W/W	3.20	3.20	
Heating Operation	Capacity(MAX)	kW	345.0	350.0	
		Btu/h	1177300	1194400	
	Power Consumption(MAX)	kW	93.8	95.5	
	COP(MAX)	W/W	3.68	3.67	
	Capacity(NOM)	kW	313.5	320.0	
		Btu/h	1069800	1092000	
Power Consumption(NOM)	kW	83.7	85.7		
COP(NOM)	W/W	3.75	3.73		
"Sound Pressure Level"※1	Normal mode	dB(A)	70	70	
	Silent mode	dB(A)	55	55	
Cabinet Color※2		—	White	White	
Outer Dimensions	Height×Width×Depth	mm	1730×6400×750	1730×6400×750	
	Packing Dimensions	Height×Width×Depth	mm	1950×6680×790	1950×6680×790
Net Weight		kg	1465	1476	
Gross Weight		kg	1599	1600	
Refrigerating Installation	Compressor		—	Twin Rotary	Twin Rotary
	Compressor Quantity		Set	8	8
	Refrigeration Oil	Type	—	FVC68D	FVC68D
		Brand	—	Idemitsu Kosan	Idemitsu Kosan
		Charge(Total)	L	34	34
	Refrigerant Charge Before Shipment		kg	45.6	45.6
	Refrigerant Flow Control		—	Micro-computer Control Expansion Valve	Micro-computer Control Expansion Valve
	Heat exchanger type		—	Multi-way cross-flow finned tube type	Multi-way cross-flow finned tube type
	Gas Pipe		mm	50.8	50.8
	Liquid Pipe		mm	25.4	25.4
Fan	Condenser Fan Quantity		—	8	8
	Air Flow Rate		m ³ /min	1400	1400
Hole for Power Supply Wiring		mm	46	46	
Hole for Control Line Wiring		mm	20	20	

Notes:

The above cooling and heating capacities show the capacities when the outdoor unit is operated with the 100% rating of indoor units,

Cooling Operation Conditions

Heating Operation Conditions

Indoor Air Inlet Temperature: 27°C DB (80°F DB)

Indoor Air Inlet Temperature: 20°C DB / (68°F DB)

19°C WB (66°F WB)

Outdoor Air Inlet Temperature: 7°C DB / (45°F DB)

Outdoor Air Inlet Temperature: 35°C DB (95°F DB)

6°C WB / (43°F WB)

Piping Length: 7.5 meters, Piping Lift: 0 meter

※1.The above noise values are measured in the anechoic chamber without reflected echo, therefore the impact of the reflected echo must be included at the scene.

Measurement point: 1 meter from the service cover surface and 1.5 meters from floor level.

※2.The final appearance of outdoor units is subject to the actual products.

2.2 Component Data

Outdoor Heat Exchanger, Fan and Fan Motor

Model			AVWT-76HKFXE	AVWT-96HKFXE	AVWT-114HKFXE	AVWT-136HKFXE	
Heat Exchanger	Heat exchanger type	-	Multi-way cross-flow finned tube type				
	Tube	Material	-	Copper			
		Outside diameter	mm	7			
		Rows	-	2	2	2	2
	Fin	Material	-	Aluminum			
		Pitch	mm	1.4	1.4	1.4	1.4
	Quantity	-	1	1	1	1	
Max. operating pressure	Mpa	4.15					
Max.frontal area	m ²	2.43	2.43	2.43	3.26		
Fan Part	Fan	Type	-	Axial-flow Fan			
		Quantity	-	1	1	1	2
		Outside diameter	mm	644	644	644	544
		Rotating speed	rpm	765	840	870	1110
	Fan motor	Type	-	DC motor			
		Start-up mode	-	Soft driving			
		Nominal output power	W	400	550	660	360+360
		Quantity	-	1	1	1	2
		Insulation grade	-	E	E	E	E

Model			AVWT-154HKFXE	AVWT-170HKFXE	AVWT-190HKFXE	AVWT-212HKFXE	
Heat Exchanger	Heat exchanger type	-	Multi-way cross-flow finned tube type				
	Tube	Material	-	Copper			
		Outside diameter	mm	7			
		Rows	-	2	3	3	3
	Fin	Material	-	Aluminum			
		Pitch	mm	1.4	1.4	1.4	1.4
	Quantity	-	1	1	1	1	
Max. operating pressure	Mpa	4.15					
Max.frontal area	m ²	3.26	3.26	3.66	3.66		
Fan Part	Fan	Type	-	Axial-flow Fan			
		Quantity	-	2	2	2	2
		Outside diameter	mm	544	544	644	644
		Rotating speed	rpm	1185	1185	960	960
	Fan motor	Type	-	DC motor			
		Start-up mode	-	Soft driving			
		Nominal output power	W	430+430	460+460	660+660	730+730
		Quantity	-	2	2	2	2
		Insulation grade	-	E	E	E	E

Model			AVWT-232HKFXE	AVWT-250HKFXE	AVWT-272HKFXE	
Heat Exchanger	Heat exchanger type	-	Multi-way cross-flow finned tube type			
	Tube	Material	-	Copper		
		Outside diameter	mm	7		
		Rows	-	3	3	3
	Fin	Material	-	Aluminum		
		Pitch	mm	1.4	1.4	1.4
	Quantity	-	1	1	1	
Max. operating pressure	Mpa	4.15				
Max.frontal area	m ²	3.66	3.98	3.98		
Fan Part	Fan	Type	-	Axial-flow Fan		
		Quantity	-	2	2	
		Outside diameter	mm	644	644	
		Rotating speed	rpm	960	960	
	Fan motor	Type	-	DC motor		
		Start-up mode	-	Soft driving		
		Nominal output power	W	750+750	800+800	820+820
		Quantity	-	2	2	
		Insulation grade	-	E	E	

Parameters of Compressor

Compressor Model			ATH550SKRC8FQP	ATE650SKTQ9JKP	ATE848SKTQ9JKP
Design Pressure	High Side	Mpa	4.15		
	Low Side	Mpa	2.21		
Compressor Motor	Model	-	Brushless DC motor		
	Start-up Mode	-	VFD		
	Polarities	-	8	6	6
	Insulation Grade	-	E		
Refrigerator Oil	Brand	-	FVC68D		
	Volume	L	1.35	2	2

Outdoor Unit Models	Compressor Model	Compressor Quantity
AVWT-76HKFXE	ATH550SKRC8FQP	1
AVWT-96HKFXE	ATH550SKRC8FQP	1
AVWT-114HKFXE	ATE650SKTQ9JKP	1
AVWT-136HKFXE	ATE848SKTQ9JKP	1
AVWT-154HKFXE	ATE848SKTQ9JKP	1
AVWT-170HKFXE	ATE848SKTQ9JKP	1
AVWT-190HKFXE	ATH550SKRC8FQP	2
AVWT-212HKFXE	ATE650SKTQ9JKP	2
AVWT-232HKFXE	ATE650SKTQ9JKP	2
AVWT-250HKFXE	ATE848SKTQ9JKP	2
AVWT-272HKFXE	ATE848SKTQ9JKP	2

2.3 Safety and Control Device Setting

- Compressor Protection

The compressor is protected by the following devices and their combinations.

- (1) High Pressure Switch: This switch cuts out the operation of the compressor when the discharge pressure exceeds the setting.
- (2) Oil Heater: This band type heater protects against oil foaming during cold starting, as it is energized while the compressor stopped.

Model			AVWT-76HKFXE	AVWT-96HKFXE	AVWT-114HKFXE	AVWT-136HKFXE	AVWT-154HKFXE
Compressor Pressure switch			Reset automatically and non-adjustable (one for each compressor)				
High	Open	MPa	4.15	4.15	4.15	4.15	4.15
	Close	MPa	3.20	3.20	3.20	3.20	3.20
Capacity of circuit breaker		A	63X2	63X2	63X2	63X2	63X2
Oil heater capacity		W	84	84	80	80	80
CCP timer Time setting		min.	Non-adjustable				
			3	3	3	3	3

Model			AVWT-170HKFXE	AVWT-190HKFXE	AVWT-212HKFXE	AVWT-232HKFXE	AVWT-250HKFXE
Compressor Pressure switch			Reset automatically and non-adjustable (one for each compressor)				
High	Open	MPa	4.15	4.15	4.15	4.15	4.15
	Close	MPa	3.20	3.20	3.20	3.20	3.20
Capacity of circuit breaker		A	63X2	63X4	63X4	63X4	63X4
Oil heater capacity		W	120	120X2	120X2	120X2	120X2
CCP timer Time setting		min.	Non-adjustable				
			3	3	3	3	3

Model			AVWT-272HKFXE
Compressor Pressure switch			Reset automatically and non-adjustable (one for each compressor)
High	Open	MPa	4.15
	Close	MPa	3.20
Capacity of circuit breaker		A	63X4
Oil heater capacity		W	120X2
CCP timer Time setting		min.	Non-adjustable
			3

2.4 Sound Data

Measurement point: 1m from the service cover surface and 1.5m from floor level.

AVWT-76HKFXE

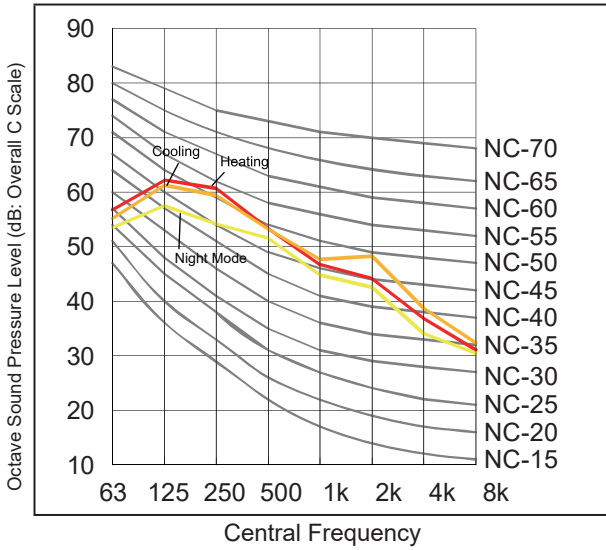

AVWT-96HKFXE

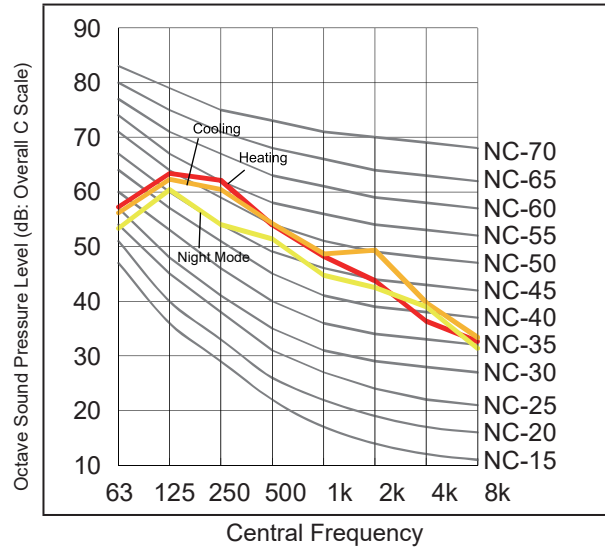

AVWT-114HKFXE

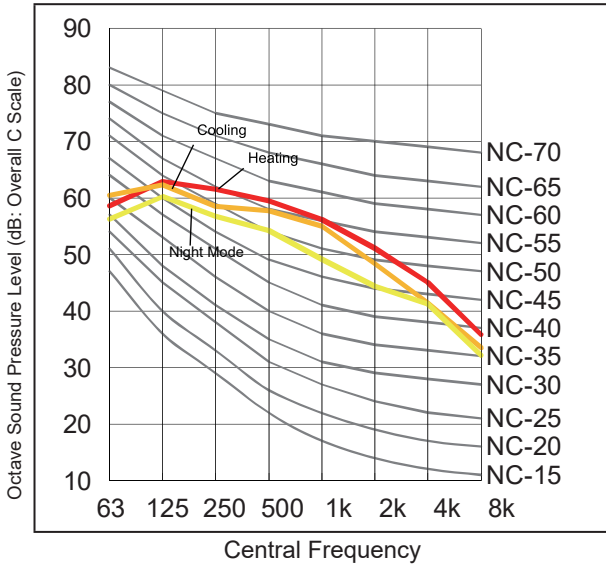

AVWT-136HKFXE

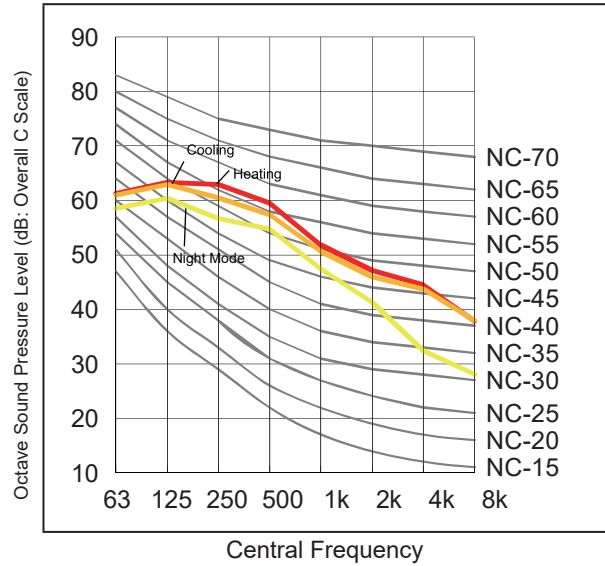

AVWT-154HKFXE

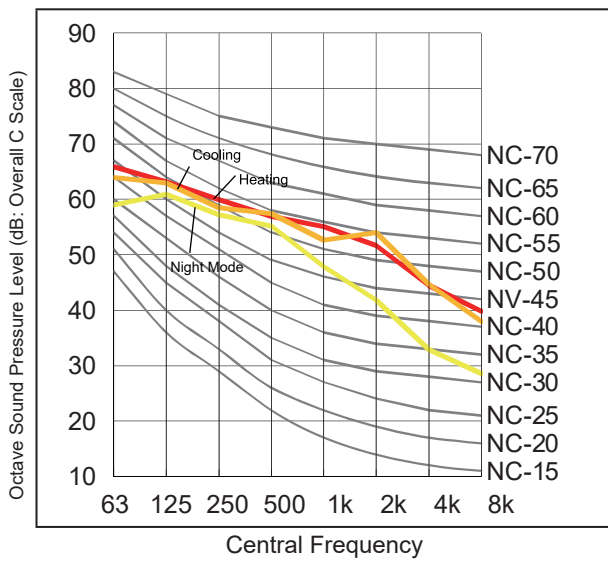

AVWT-170HKFXE

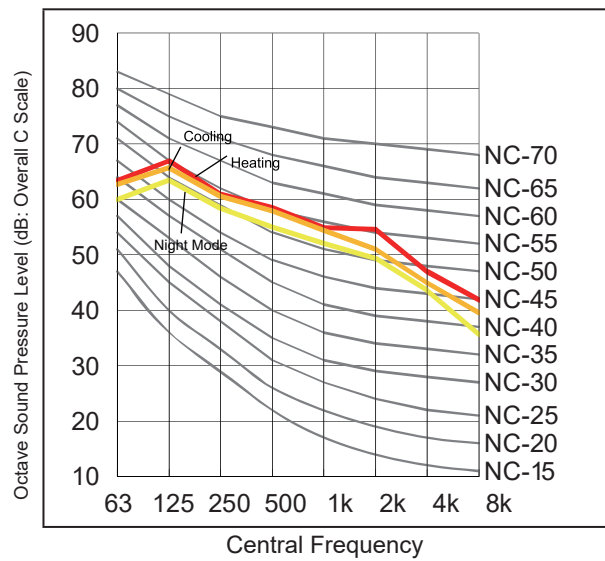

AVWT-190HKFXE

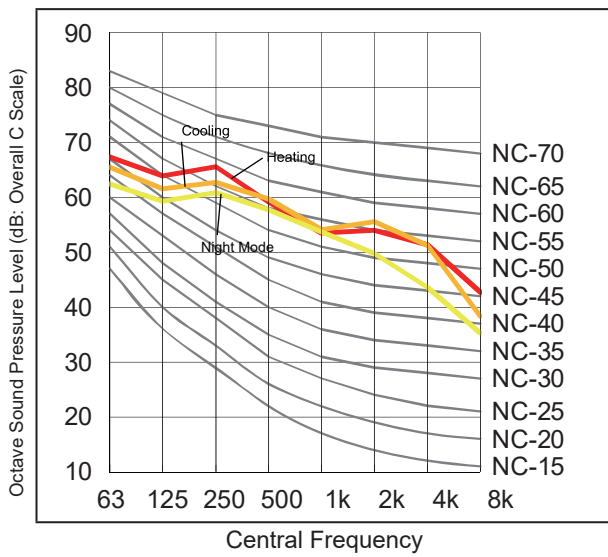

AVWT-212HKFXE

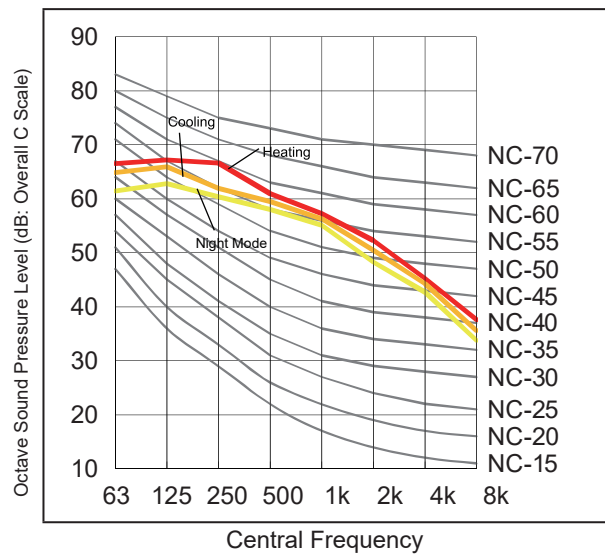

AVWT-232HKFXE

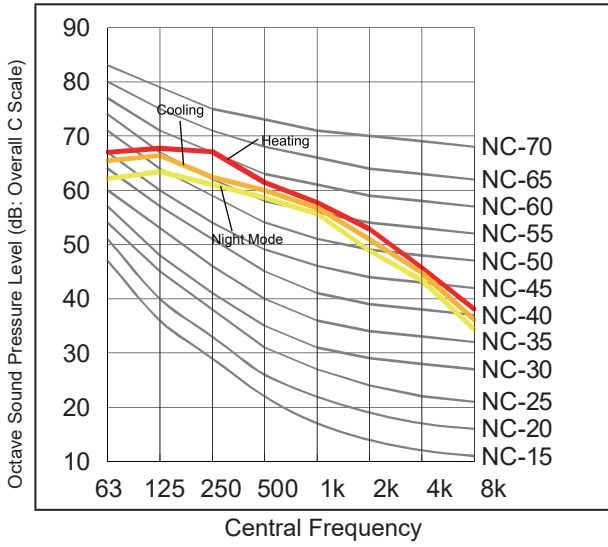

AVWT-250HKFXE

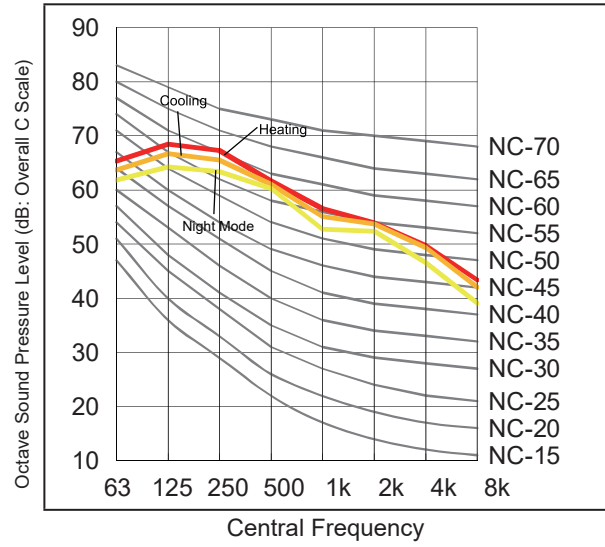

AVWT-272HKFXE

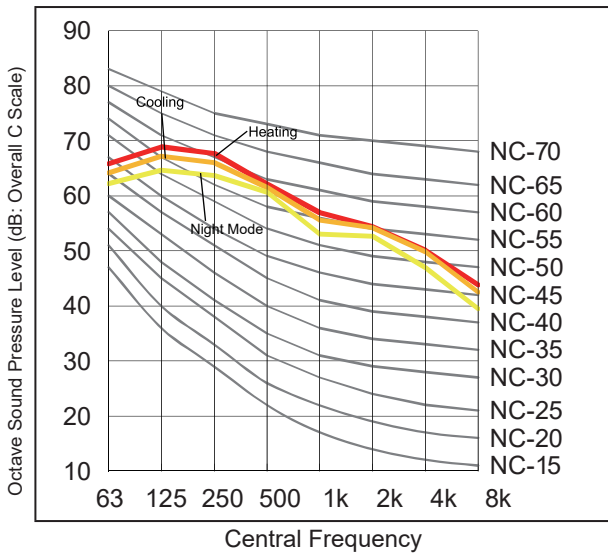

2.5 Dimensional Data

Model: AVWT-76*, AVWT-96*, AVWT-114*

unit: mm

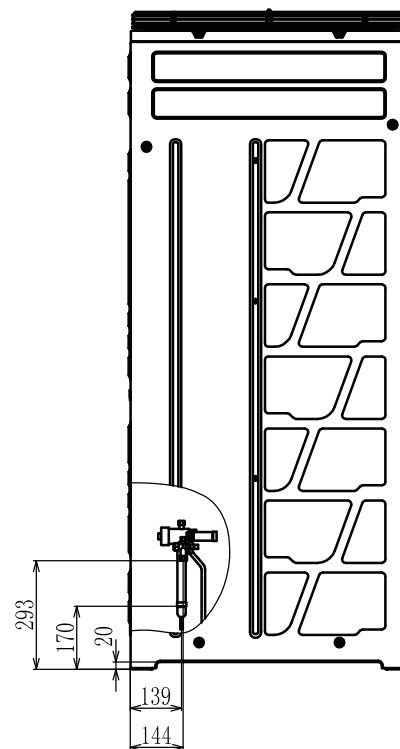
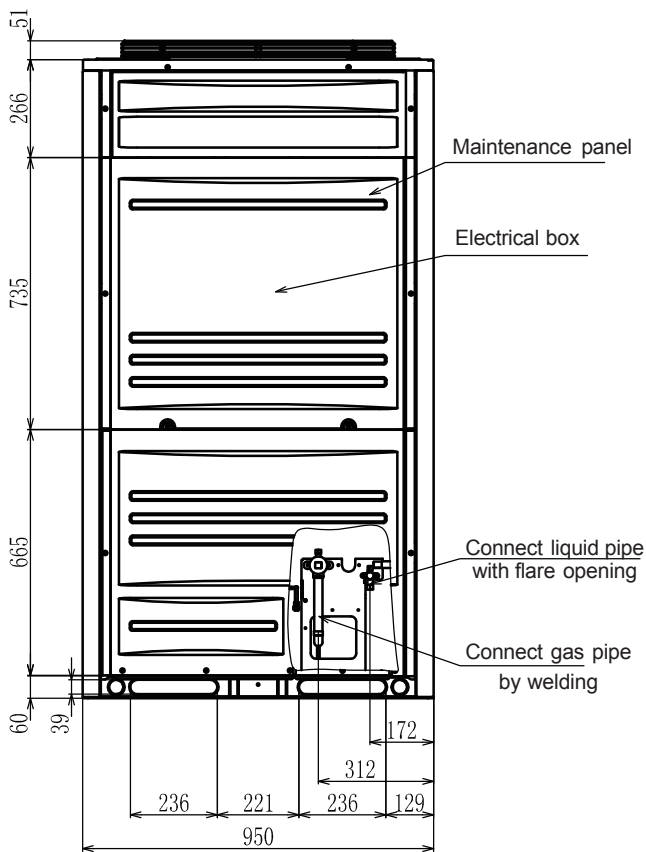
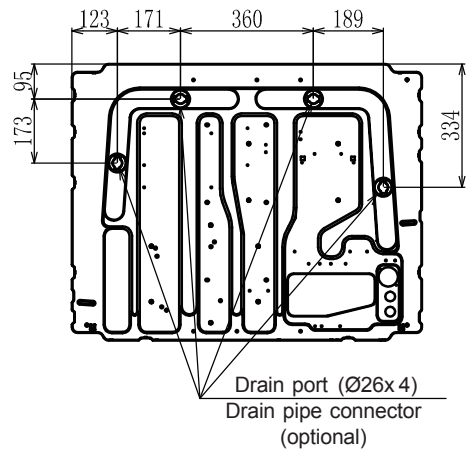
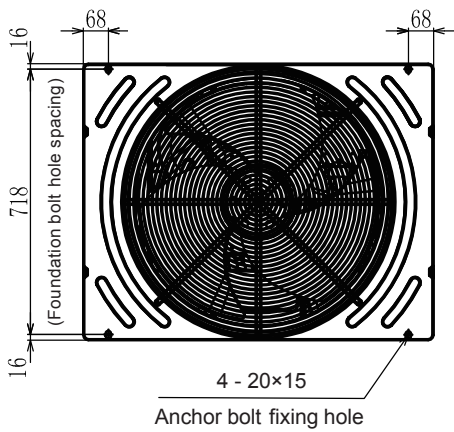

Model: AVWT-136*, AVWT-154*, AVWT-170*

unit: mm

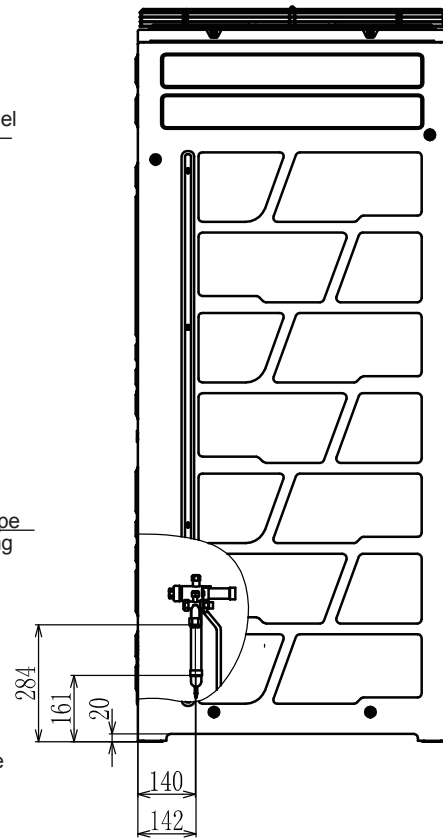
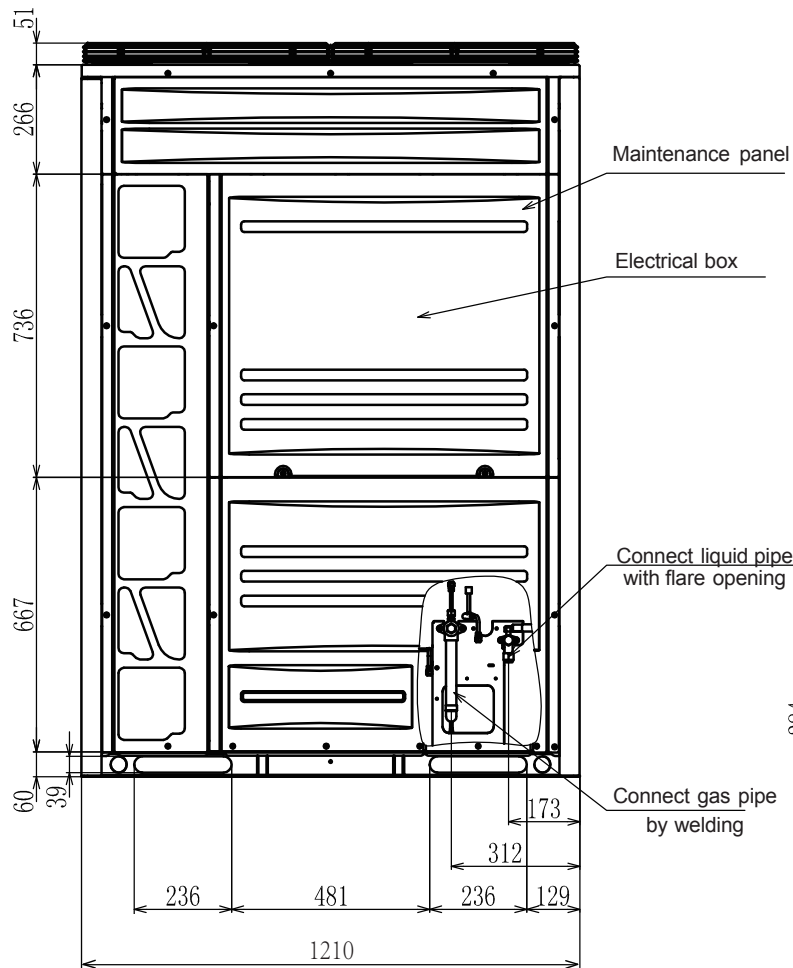
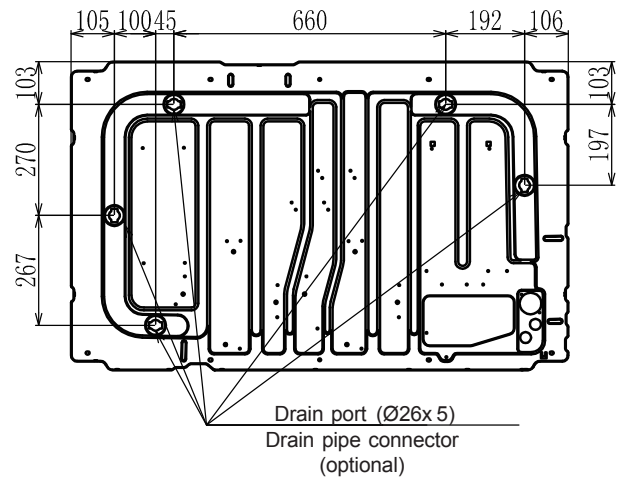
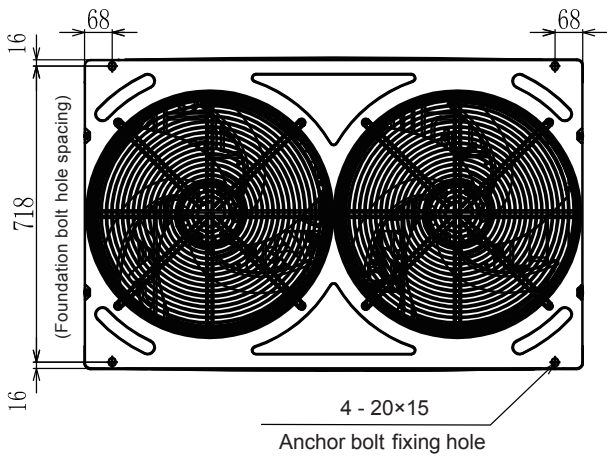

General Data

Model: AVWT-190*, AVWT-212*, AVWT-232*

unit: mm

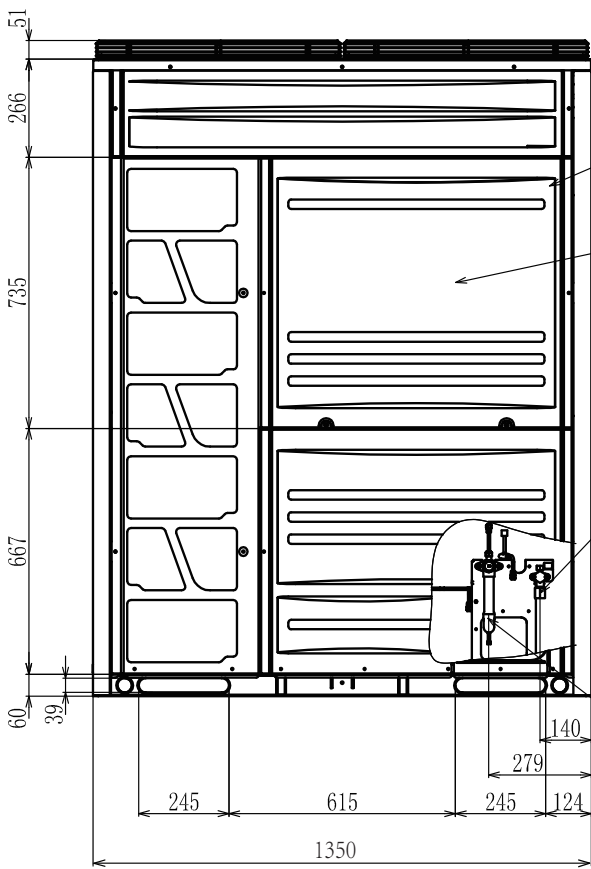
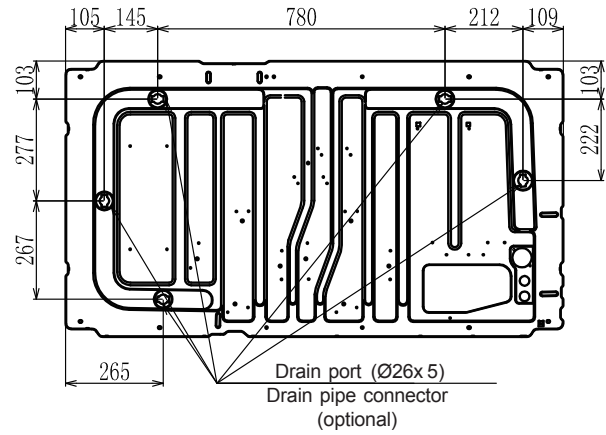
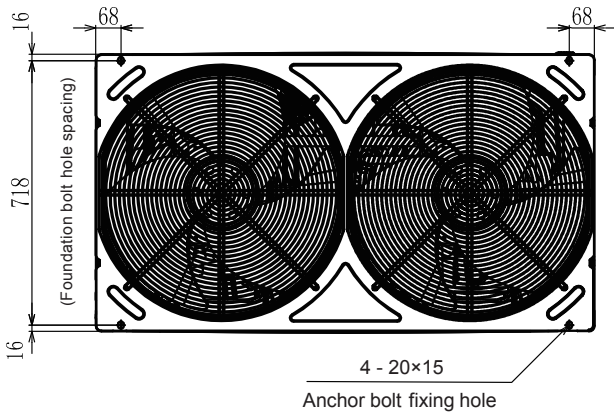

Maintenance panel

Electrical box

Connect liquid pipe with flare opening

Connect gas pipe by welding

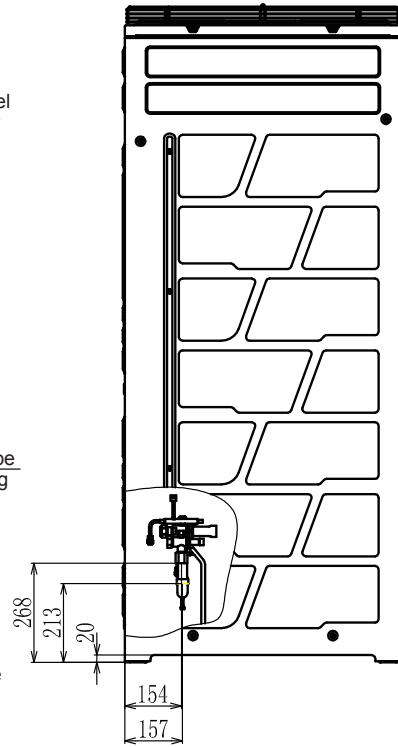

Model: AVWT-250*, AVWT-272*

unit: mm

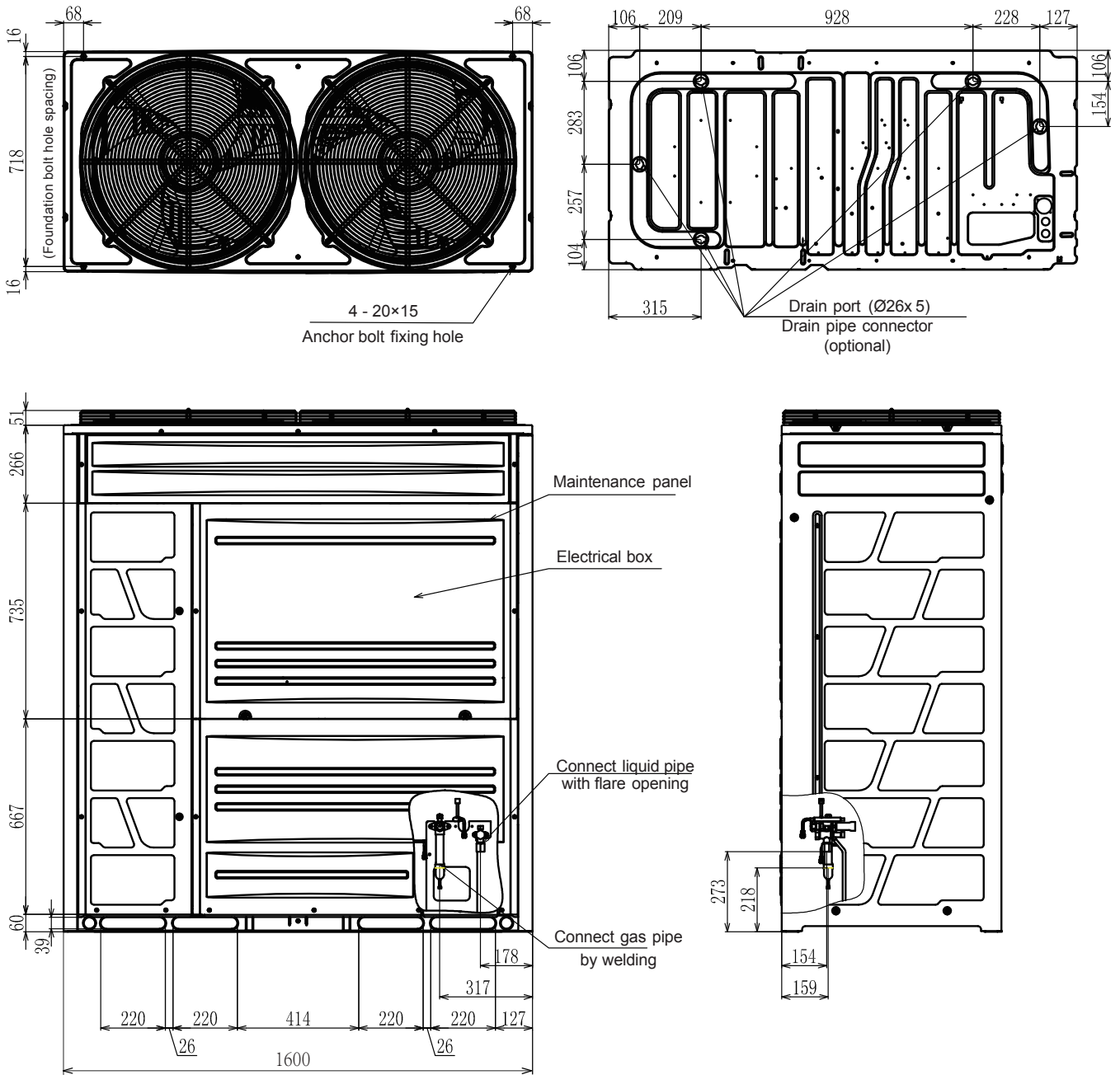

2.6 Structure

AVWT-76-114*

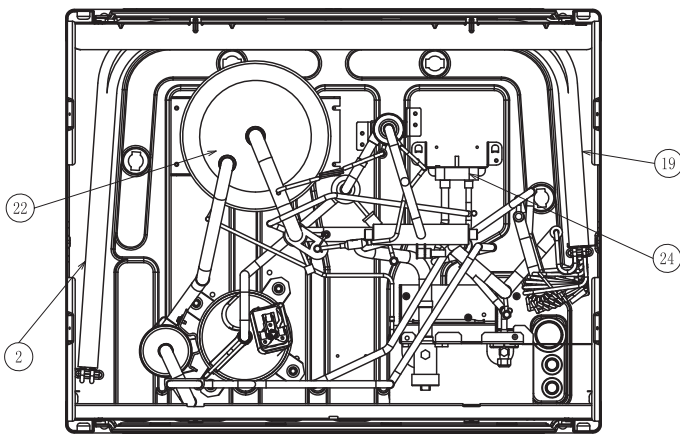

SN	Part Name	SN	Part Name
1	Compressor	13	Check joint
2	Heat exchanger	14	Solenoid valve
3	Strainer	15	Capillary tube
4	Splitter	16	Crankcase heater
5	4-way reversing valve	17	Propeller fan
6	Electronic expansion valve (EVO)	18	Damping rubber pad
7	Stop valve (liquid)	19	Inlet
8	Stop valve (gas)	20	Outlet
9	Electrical box	21	Wooden pallet
10	High pressure switch	22	Accumulator
11	High pressure sensor	23	Oil separator
12	Low pressure sensor	24	Subcooler

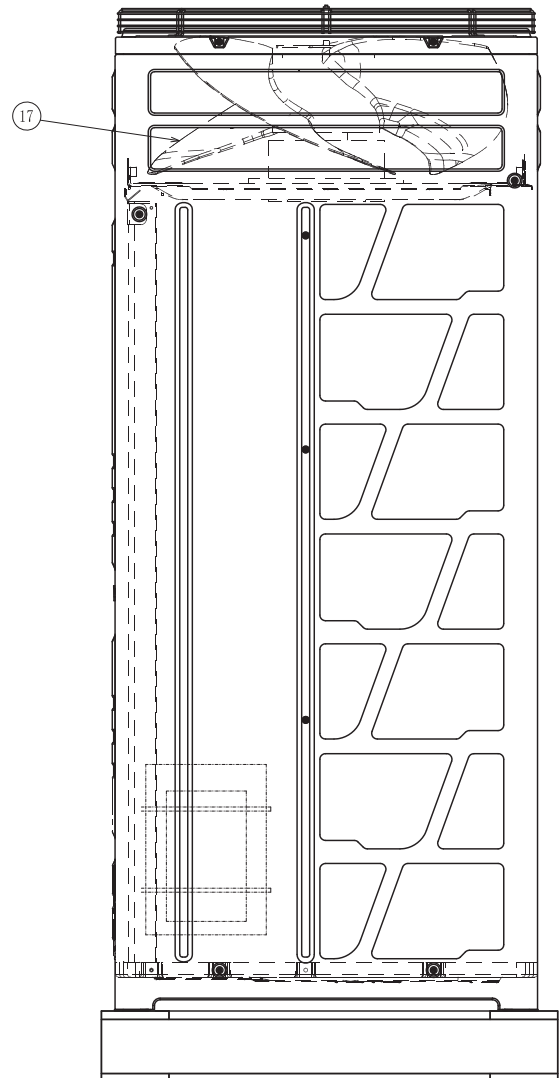
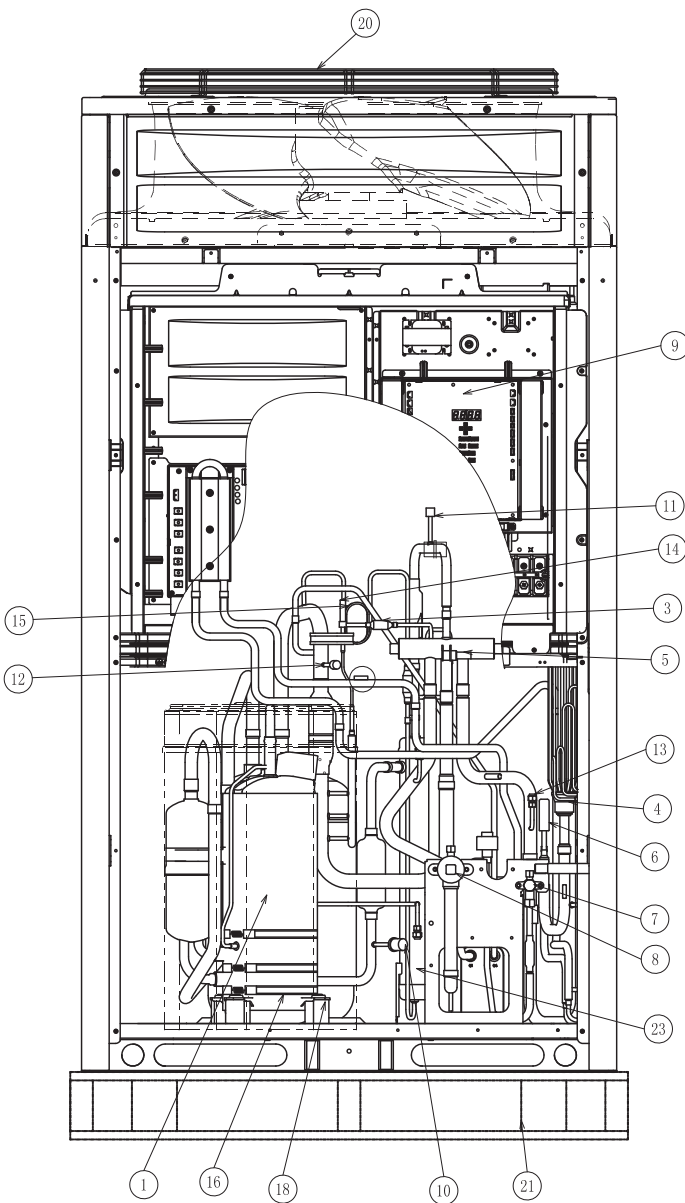

AVWT-136-170*

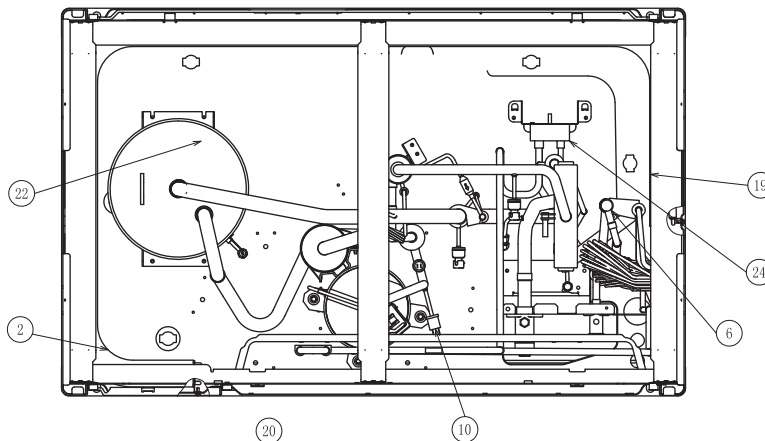

SN	Part Name	SN	Part Name
1	Compressor	13	Check joint
2	Heat exchanger	14	Solenoid valve
3	Strainer	15	Capillary tube
4	Splitter	16	Crankcase heater
5	4-way reversing valve	17	Propeller fan
6	Electronic expansion valve (EVO)	18	Damping rubber pad
7	Stop valve (liquid)	19	Inlet
8	Stop valve (gas)	20	Outlet
9	Electrical box	21	Wooden pallet
10	High pressure switch	22	Accumulator
11	High pressure sensor	23	Oil separator
12	Low pressure sensor	24	Subcooler

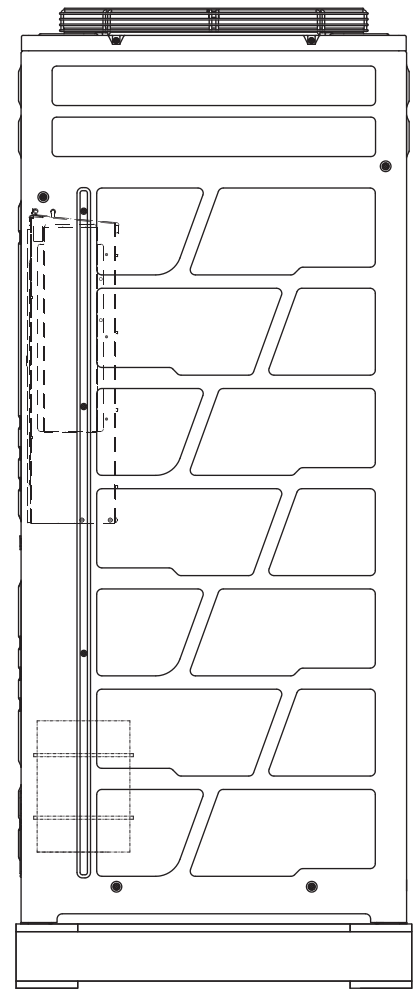
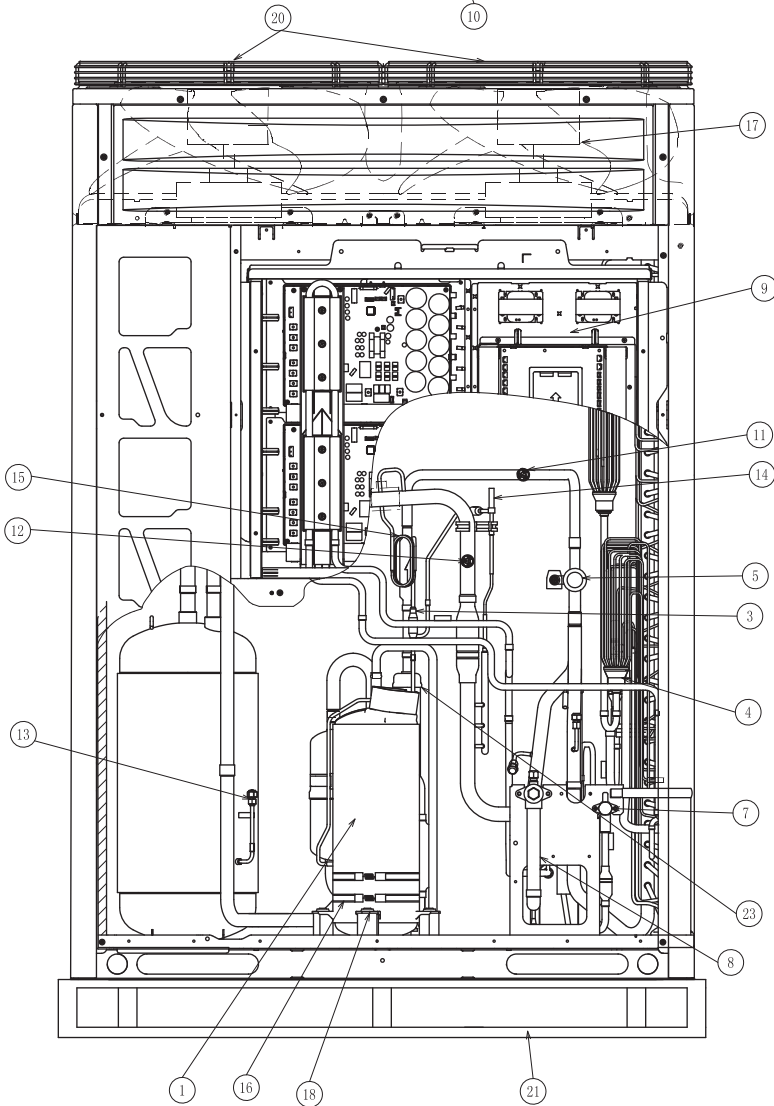

AVWT-190-272*

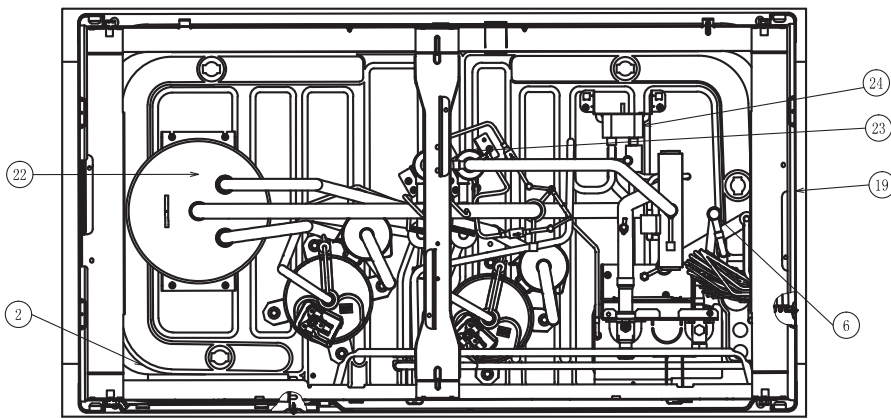

SN	Part Name	SN	Part Name
1	Compressor	13	Check joint
2	Heat exchanger	14	Solenoid valve
3	Strainer	15	Capillary tube
4	Splitter	16	Crankcase heater
5	4-way reversing valve	17	Propeller fan
6	Electronic expansion valve (EVO)	18	Damping rubber pad
7	Stop valve (liquid)	19	Inlet
8	Stop valve (gas)	20	Outlet
9	Electrical box	21	Wooden pallet
10	High pressure switch	22	Accumulator
11	High pressure sensor	23	Oil separator
12	Low pressure sensor	24	Subcooler

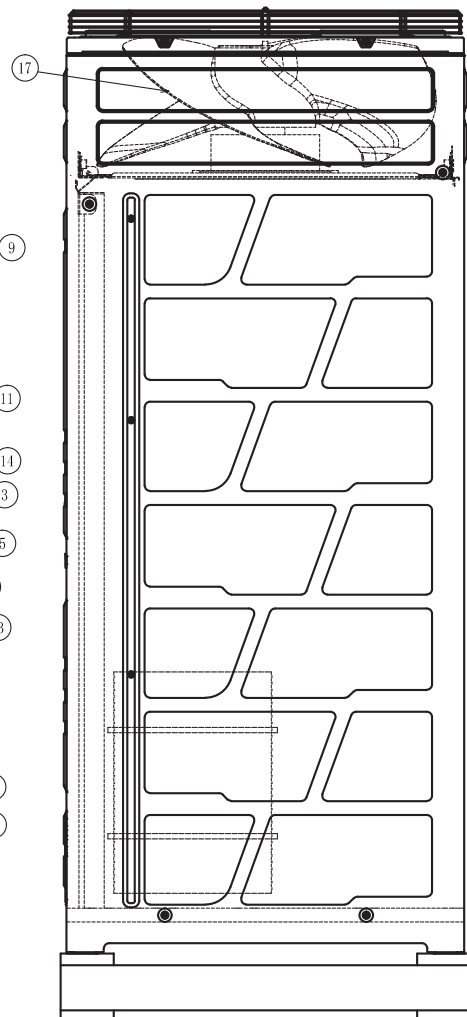
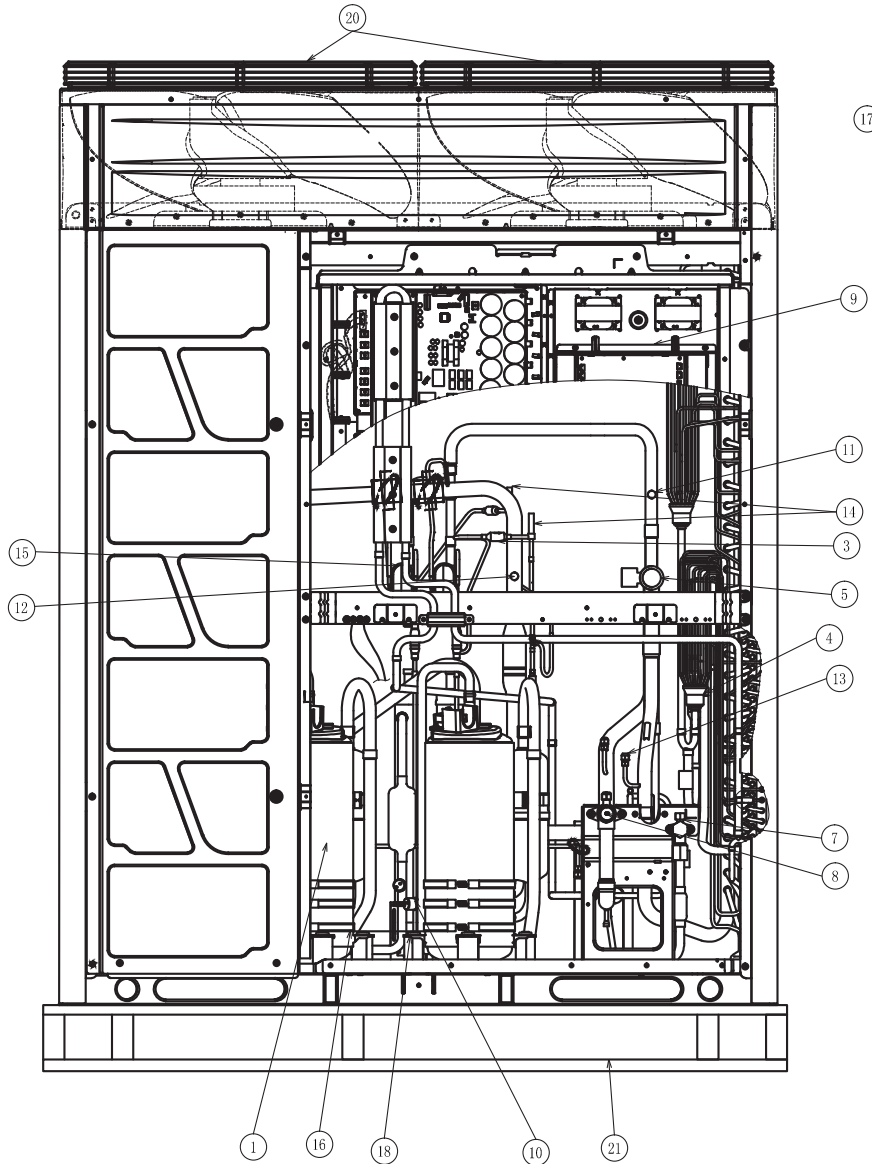

3. Piping System

3.1 Connection of Refrigerant Pipes for Standard Combination Models

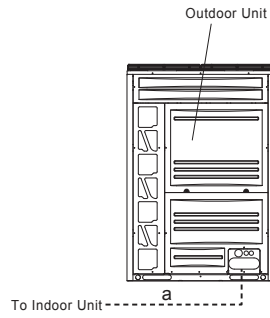

(Φmm)

Model		AVWT-76HKFXE	AVWT-96HKFXE	AVWT-114HKFXE	AVWT-136HKFXE	AVWT-154HKFXE	
Piping Size	a	Gas	19.05	22.2	25.4	25.4	28.6
		Liquid	9.53	9.53	12.7	12.7	12.7

Model		AVWT-170HKFXE	AVWT-190HKFXE	AVWT-212HKFXE	AVWT-232HKFXE	AVWT-250HKFXE	
Piping Size	a	Gas	28.6	28.6	28.6	28.6	31.75
		Liquid	15.88	15.88	15.88	15.88	19.05

Model		AVWT-272HKFXE	
Piping Size	a	Gas	31.75
		Liquid	19.05

- Piping Size for AVWT-290HKFXE~AVWT-544HKFXE (Two-Unit-Combination)

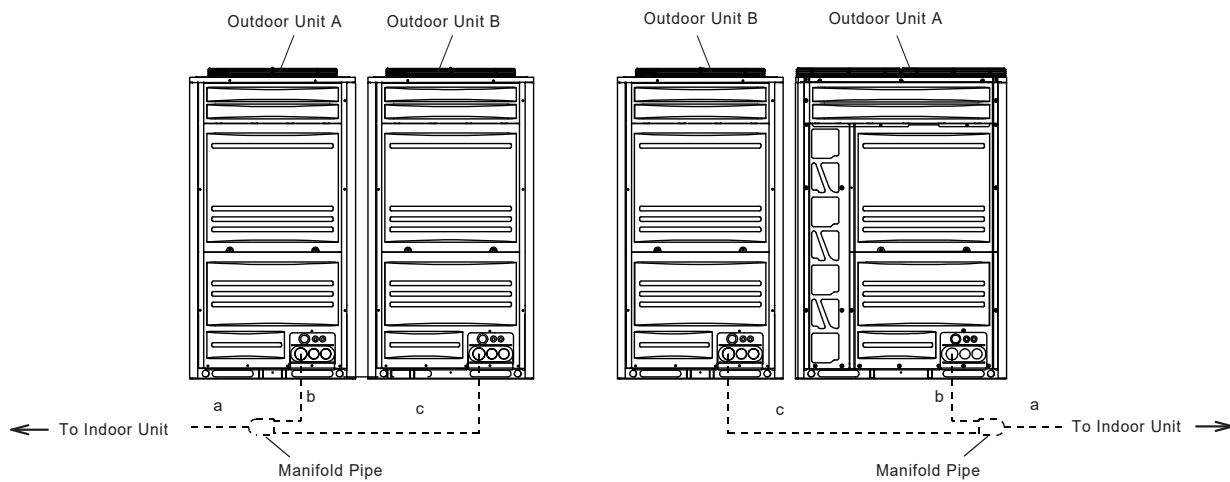

(Φmm)

Model		AVWT-290HKFXE	AVWT-308HKFXE	AVWT-326HKFXE	AVWT-344HKFXE	AVWT-366HKFXE	
Combination Unit	Outdoor Unit A	AVWT-154HKFXE	AVWT-154HKFXE	AVWT-190HKFXE	AVWT-190HKFXE	AVWT-212HKFXE	
	Outdoor Unit B	AVWT-136HKFXE	AVWT-154HKFXE	AVWT-136HKFXE	AVWT-154HKFXE	AVWT-154HKFXE	
Manifold Pipe		HFQ-M32F					
Piping Size	a	Gas	31.75	31.75	38.1	38.1	38.1
		Liquid	19.05	19.05	19.05	19.05	19.05
	b	Gas	28.6	28.6	28.6	28.6	28.6
		Liquid	12.7	12.7	15.88	15.88	15.88
	c	Gas	25.4	28.6	28.6	28.6	28.6
		Liquid	12.7	12.7	12.7	12.7	12.7

Model		AVWT-386HKFXE	AVWT-402HKFXE	AVWT-422HKFXE	AVWT-444HKFXE	AVWT-464HKFXE	
Combination Unit	Outdoor Unit A	AVWT-232HKFXE	AVWT-212HKFXE	AVWT-232HKFXE	AVWT-232HKFXE	AVWT-232HKFXE	
	Outdoor Unit B	AVWT-154HKFXE	AVWT-190HKFXE	AVWT-190HKFXE	AVWT-212HKFXE	AVWT-232HKFXE	
Manifold Pipe		HFQ-M32F			HFQ-M462F		
Piping Size	a	Gas	38.1	38.1	38.1	41.3	41.3
		Liquid	19.05	19.05	19.05	22.2	22.2
	b	Gas	28.6	28.6	28.6	28.6	28.6
		Liquid	15.88	15.88	15.88	15.88	15.88
	c	Gas	28.6	28.6	28.6	28.6	28.6
		Liquid	12.7	15.88	15.88	15.88	15.88

Model		AVWT-482HKFXE	AVWT-504HKFXE	AVWT-522HKFXE	AVWT-544HKFXE	
Combination Unit	Outdoor Unit A	AVWT-250HKFXE	AVWT-272HKFXE	AVWT-272HKFXE	AVWT-272HKFXE	
	Outdoor Unit B	AVWT-232HKFXE	AVWT-232HKFXE	AVWT-250HKFXE	AVWT-272HKFXE	
Manifold Pipe		HFQ-M462F				
Piping Size	a	Gas	41.3	41.3	41.3	41.3
		Liquid	22.2	22.2	22.2	22.2
	b	Gas	31.75	31.75	31.75	31.75
		Liquid	19.05	19.05	19.05	19.05
	c	Gas	28.6	28.6	31.75	31.75
		Liquid	15.88	15.88	19.05	19.05

-Perform piping for outdoor unit in accordance with the requirements as set forth above.
 Select manifold pipe model and tube size by referring to the models of outdoor unit provided above.

(Φmm)

- Piping Size for AVWT-556HKFXE~ AVWT-816HKFXE(Three-Unit-Combination)

Indoor unit on left side

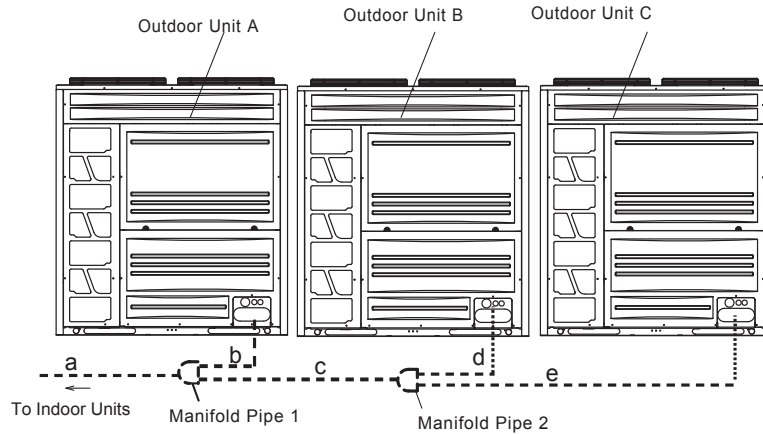

Indoor unit on right side

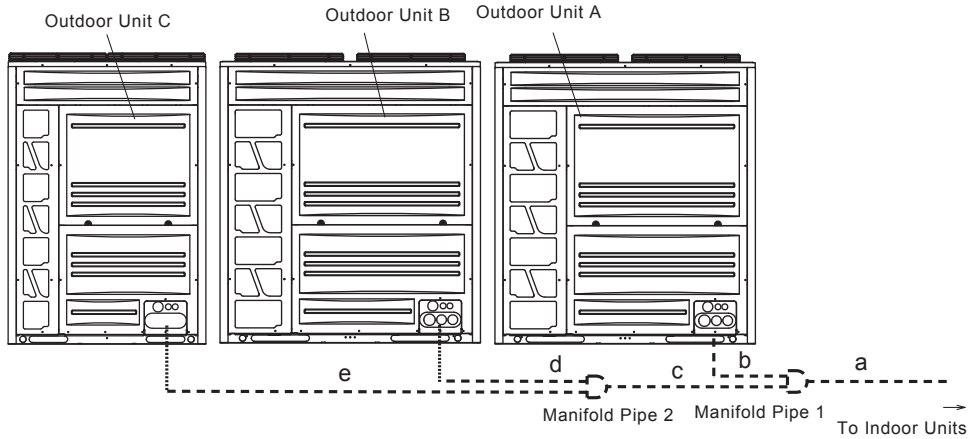

(Φmm)

Model		AVWT-556HKFXE	AVWT-576HKFXE	AVWT-598HKFXE	AVWT-618HKFXE	AVWT-634HKFXE	
Combination Unit	Outdoor Unit A	AVWT-212HKFXE	AVWT-232HKFXE	AVWT-232HKFXE	AVWT-232HKFXE	AVWT-232HKFXE	
	Outdoor Unit B	AVWT-190HKFXE	AVWT-190HKFXE	AVWT-212HKFXE	AVWT-232HKFXE	AVWT-212HKFXE	
	Outdoor Unit C	AVWT-154HKFXE	AVWT-154HKFXE	AVWT-154HKFXE	AVWT-154HKFXE	AVWT-190HKFXE	
Manifold Pipe 1		HFQ-M462F					
Manifold Pipe 2		HFQ-M32F					
Piping Size	a	Gas	44.5	44.5	44.5	44.5	44.5
		Liquid	22.2	22.2	22.2	22.2	22.2
	b	Gas	28.6	28.6	28.6	28.6	28.6
		Liquid	15.88	15.88	15.88	15.88	15.88
	c	Gas	38.1	38.1	38.1	38.1	38.1
		Liquid	19.05	19.05	19.05	19.05	19.05
	d	Gas	28.6	28.6	28.6	28.6	28.6
		Liquid	15.88	15.88	15.88	15.88	15.88
	e	Gas	28.6	28.6	28.6	28.6	28.6
		Liquid	12.7	12.7	12.7	15.88	15.88

(Φmm)

Model		AVWT-654HKFXE	AVWT-676HKFXE	AVWT-696HKFXE	AVWT-714HKFXE	AVWT-732HKFXE
Combination Unit	Outdoor Unit A	AVWT-232HKFXE	AVWT-232HKFXE	AVWT-232HKFXE	AVWT-250HKFXE	AVWT-250HKFXE
	Outdoor Unit B	AVWT-232HKFXE	AVWT-232HKFXE	AVWT-232HKFXE	AVWT-232HKFXE	AVWT-250HKFXE
	Outdoor Unit C	AVWT-190HKFXE	AVWT-212HKFXE	AVWT-232HKFXE	AVWT-232HKFXE	AVWT-232HKFXE
Manifold Pipe 1		HFQ-M682F			HFQ-M682F	
Manifold Pipe 2		HFQ-M32F			HFQ-M462F	
Piping Size	a	Gas	50.8	50.8	50.8	50.8
		Liquid	25.4	25.4	25.4	25.4
	b	Gas	28.6	28.6	28.6	31.75
		Liquid	15.88	15.88	15.88	19.05
	c	Gas	38.1	41.3	41.3	41.3
		Liquid	19.05	22.2	22.2	22.2
	d	Gas	28.6	28.6	28.6	28.6
		Liquid	15.88	15.88	15.88	15.88
	e	Gas	28.6	28.6	28.6	28.6
		Liquid	15.88	15.88	15.88	15.88

(Φmm)

Model		AVWT-754HKFXE	AVWT-776HKFXE	AVWT-794HKFXE	AVWT-816HKFXE
Combination Unit	Outdoor Unit A	AVWT-272HKFXE	AVWT-272HKFXE	AVWT-272HKFXE	AVWT-272HKFXE
	Outdoor Unit B	AVWT-250HKFXE	AVWT-272HKFXE	AVWT-272HKFXE	AVWT-272HKFXE
	Outdoor Unit C	AVWT-232HKFXE	AVWT-232HKFXE	AVWT-250HKFXE	AVWT-272HKFXE
Manifold Pipe 1		HFQ-M682F			
Manifold Pipe 2		HFQ-M462F			
Piping Size	a	Gas	50.8	50.8	50.8
		Liquid	25.4	25.4	25.4
	b	Gas	31.75	31.75	31.75
		Liquid	19.05	19.05	19.05
	c	Gas	41.3	41.3	41.3
		Liquid	22.2	22.2	22.2
	d	Gas	31.75	31.75	31.75
		Liquid	19.05	19.05	19.05
	e	Gas	28.6	28.6	31.75
		Liquid	15.88	15.88	19.05

-Perform piping for outdoor unit in accordance with the requirements as set forth above.
 Select manifold pipe model and tube size by referring to the models of outdoor unit provided above.

- Piping Size for AVWT-824HKFXE~AVWT-1088HKFXE (Four-Unit-Combination)

Indoor Unit at the left side

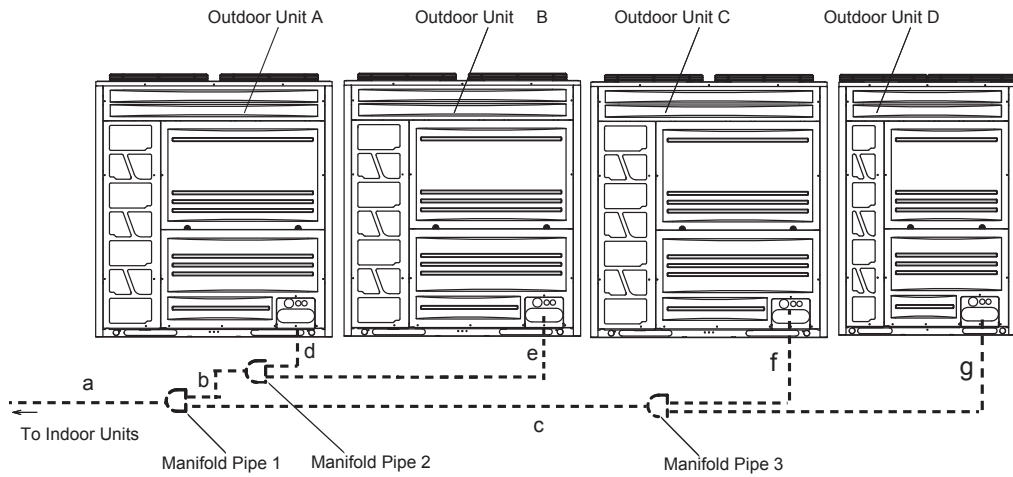

Indoor unit at the right side

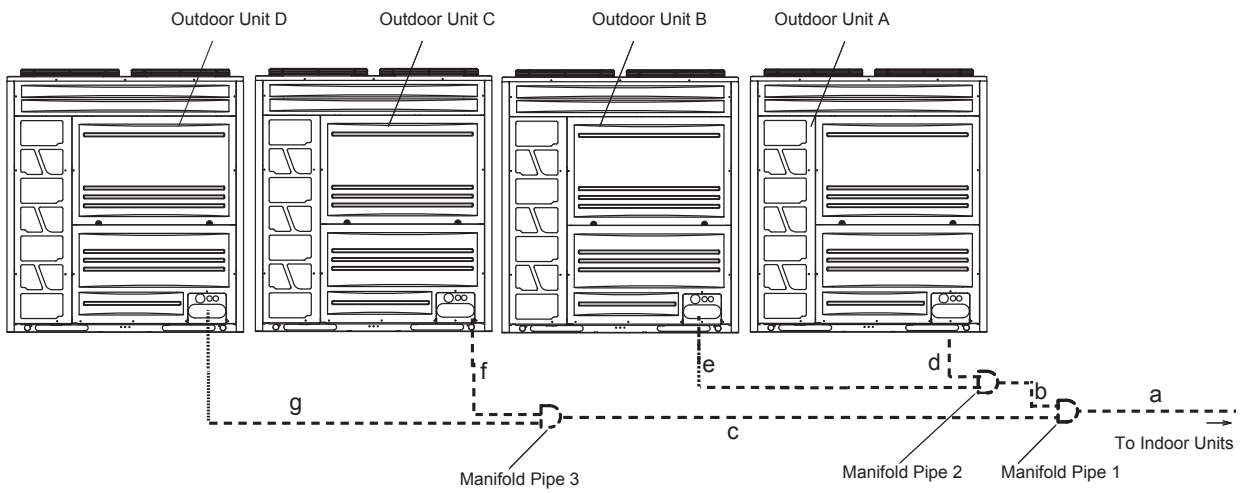

(Φmm)

Model		AVWT-824HKFXE	AVWT-844HKFXE	AVWT-866HKFXE	AVWT-886HKFXE	AVWT-908HKFXE	
Combination Unit	Outdoor Unit A	AVWT-232HKFXE	AVWT-232HKFXE	AVWT-232HKFXE	AVWT-232HKFXE	AVWT-232HKFXE	
	Outdoor Unit B	AVWT-212HKFXE	AVWT-232HKFXE	AVWT-232HKFXE	AVWT-232HKFXE	AVWT-232HKFXE	
	Outdoor Unit C	AVWT-190HKFXE	AVWT-190HKFXE	AVWT-212HKFXE	AVWT-232HKFXE	AVWT-232HKFXE	
	Outdoor Unit D	AVWT-190HKFXE	AVWT-190HKFXE	AVWT-190HKFXE	AVWT-190HKFXE	AVWT-212HKFXE	
Manifold Pipe 1		HFQ-M682F				HFQ-M682F	
Manifold Pipe 2		HFQ-M462F				HFQ-M462F	
Manifold Pipe 2		HFQ-M32F				HFQ-M462F	
Piping Size	a	Gas	50.8	50.8	50.8	50.8	50.8
		Liquid	25.4	25.4	25.4	25.4	25.4
	b	Gas	41.3	41.3	41.3	41.3	41.3
		Liquid	22.2	22.2	22.2	22.2	22.2
	c	Gas	38.1	38.1	38.1	38.1	41.3
		Liquid	19.05	19.05	19.05	19.05	22.2
	d	Gas	28.6	28.6	28.6	28.6	28.6
		Liquid	15.88	15.88	15.88	15.88	15.88
	e	Gas	28.6	28.6	28.6	28.6	28.6
		Liquid	15.88	15.88	15.88	15.88	15.88
	f	Gas	28.6	28.6	28.6	28.6	28.6
		Liquid	15.88	15.88	15.88	15.88	15.88
	g	Gas	28.6	28.6	28.6	28.6	28.6
		Liquid	15.88	15.88	15.88	15.88	15.88

(Φmm)

Model		AVWT-928HKFXE	AVWT-946HKFXE	AVWT-968HKFXE	AVWT-986HKFXE	AVWT-1008HKFXE	
Combination Unit	Outdoor Unit A	AVWT-232HKFXE	AVWT-250HKFXE	AVWT-272HKFXE	AVWT-272HKFXE	AVWT-272HKFXE	
	Outdoor Unit B	AVWT-232HKFXE	AVWT-232HKFXE	AVWT-232HKFXE	AVWT-250HKFXE	AVWT-272HKFXE	
	Outdoor Unit C	AVWT-232HKFXE	AVWT-232HKFXE	AVWT-232HKFXE	AVWT-232HKFXE	AVWT-232HKFXE	
	Outdoor Unit D	AVWT-232HKFXE	AVWT-232HKFXE	AVWT-232HKFXE	AVWT-232HKFXE	AVWT-232HKFXE	
Manifold Pipe 1		HFQ-M682F			HFQ-M682F		
Manifold Pipe 2		HFQ-M462F			HFQ-M462F		
Manifold Pipe 3		HFQ-M462F			HFQ-M462F		
Piping Size	a	Gas	50.8	50.8	50.8	50.8	50.8
		Liquid	25.4	25.4	25.4	25.4	25.4
	b	Gas	41.3	41.3	41.3	41.3	41.3
		Liquid	22.2	22.2	22.2	22.2	22.2
	c	Gas	41.3	41.3	41.3	41.3	41.3
		Liquid	22.2	22.2	22.2	22.2	22.2
	d	Gas	28.6	31.75	31.75	31.75	31.75
		Liquid	15.88	19.05	19.05	19.05	19.05
	e	Gas	28.6	28.6	28.6	31.75	31.75
		Liquid	15.88	15.88	15.88	19.05	19.05
	f	Gas	28.6	28.6	28.6	28.6	28.6
		Liquid	15.88	15.88	15.88	15.88	15.88
	g	Gas	28.6	28.6	28.6	28.6	28.6
		Liquid	15.88	15.88	15.88	15.88	15.88

(Φmm)

Model		AVWT-1026HKFXE	AVWT-1048HKFXE	AVWT-1066HKFXE	AVWT-1088HKFXE	
Combination Unit	Outdoor Unit A	AVWT-272HKFXE	AVWT-272HKFXE	AVWT-272HKFXE	AVWT-272HKFXE	
	Outdoor Unit B	AVWT-272HKFXE	AVWT-272HKFXE	AVWT-272HKFXE	AVWT-272HKFXE	
	Outdoor Unit C	AVWT-250HKFXE	AVWT-272HKFXE	AVWT-272HKFXE	AVWT-272HKFXE	
	Outdoor Unit D	AVWT-232HKFXE	AVWT-232HKFXE	AVWT-250HKFXE	AVWT-272HKFXE	
Manifold Pipe 1		HFQ-M682F				
Manifold Pipe 2		HFQ-M462F				
Manifold Pipe 3		HFQ-M462F				
Piping Size	a	Gas	50.8	50.8	50.8	50.8
		Liquid	25.4	25.4	25.4	25.4
	b	Gas	41.3	41.3	41.3	41.3
		Liquid	22.2	22.2	22.2	22.2
	c	Gas	41.3	41.3	41.3	41.3
		Liquid	22.2	22.2	22.2	22.2
	d	Gas	31.75	31.75	31.75	31.75
		Liquid	19.05	19.05	19.05	19.05
	e	Gas	31.75	31.75	31.75	31.75
		Liquid	19.05	19.05	19.05	19.05
	f	Gas	31.75	31.75	31.75	31.75
		Liquid	19.05	19.05	19.05	19.05
	g	Gas	28.6	28.6	31.75	31.75
		Liquid	15.88	15.88	19.05	19.05

-Perform piping for outdoor units in accordance with the requirements as set forth above.
 Select manifold model and tube size by referring to the models of outdoor units provided above.

3.2 Pipe Connection Design Guidance

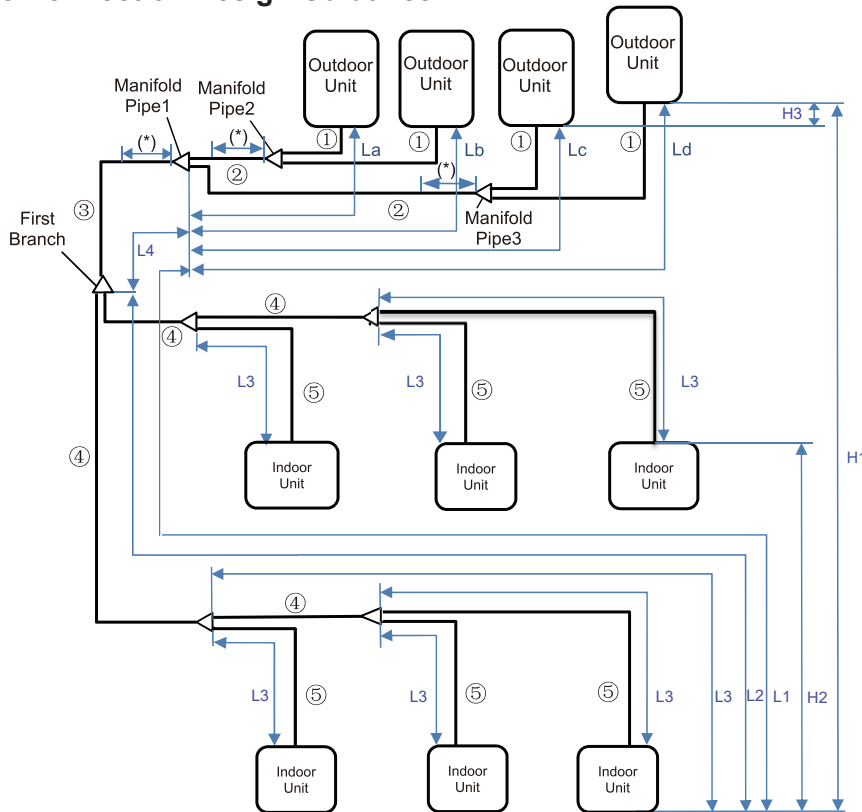

(*): Keep the straight distance of 500mm or more after the Manifold Pipe.

• Piping Work Conditions

Item	Mark	Allowable Piping Length	
		≤ the recommended connectable number of Indoor Unit	≥ the recommended connectable number of Indoor Unit
Total Piping Length	Total Liquid Piping Actual	≤ 1,000m	≤ 300m
Maximum Piping Length	Actual Length	≤ 165m	≤ 115m
	Equivalent Length	≤ 190m	≤ 130m
Maximum Piping Length between First Branch and Each Indoor Unit	L2	≤ 90m	≤ 40m
Maximum Piping Length between Each Branch Pipe and Each Indoor Unit	L3	≤ 40m	≤ 30m
Maximum Piping Length between Manifold Pipe 1 and First Branch	L4	≤ 75m	≤ 75m
Piping Length between Manifold Pipe 1 and Each Outdoor Unit	La, Lb, Lc, Ld	≤ 10m	≤ 10m
Height Difference between Outdoor Units and Indoor Units	O.U. is Higher	≤ 50m	≤ 50m
	O.U. is Lower	≤ 40m	≤ 40m
Height Difference between Indoor Units	H2	≤ 30m	≤ 30m
Height Difference between Outdoor Units	H3	≤ 0.1m	≤ 0.1m

NOTES:

1. Check the gas pipe and liquid pipe are equivalent in terms of the piping length and piping system.
2. Piping length between outdoor units should be $L_a \leq L_b \leq L_c \leq L_d \leq 10m$.
3. If the piping length (L3) between some Branch Pipe and indoor unit is considerably longer than others, refrigerant may not flow well and also performance may be deteriorated compared to other models (Recommended Piping Length: $L_3 \leq 15m$). When the liquid piping length is longer than 15m, use $\Phi 9.53$ pipe with reducer (field-supplied).
4. Allowable total piping length may become shorter than 1,000m due to the limitation of maximum additional refrigerant amount.
5. Function setting Ci is required ($C_i=2$) in case of height difference between indoor units: $15m < H_2 < 30m$.
6. In case of height difference between outdoor units and indoor units: $50m(40m) < H_1 < 90m$, contact technical department of the manufacture.

①② Piping between outdoor unit refer to item 3.1 and item 3.2.

③ Main pipe (basic unit or manifold pipe 1 to first branch)

Outdoor Unit Capacity (kBtu/h)	Gas (Φ mm)	Liquid (Φ mm)	First Branch Model
76 (8HP)	19.05	9.53	HFQ-102F
96 (10HP)	22.20	9.53	
114~136 (12~14HP)	25.40	12.70	HFQ-162F
154 (16HP)	28.60	12.70	
170~232 (18~24HP)	28.60	15.88	HFQ-242F
250~308 (26~32HP)	31.75	19.05	HFQ-302F
326~422 (34~44HP)	38.10	19.05	
444~544 (46~56HP)	41.30	22.20	HFQ-462F
556~634 (58~66HP)	44.50	22.20	
654~1088 (68~112HP)	50.80	25.40	HFQ-682F

NOTE:

When maximum length of the equivalent refrigerant pipe (L1) from the outdoor unit/manifold pipe1 to the indoor unit is over 100m, the pipe size of gas and liquid line from basic unit/manifold pipe1 to first branch should be increased one size with the reducer (field-supplied).

④ Pipe after first branch

Total Indoor Unit Capacity (kBtu/h)	Gas (Φ mm)	Liquid (Φ mm)	Model
Q ≤ 54(6HP)	15.88	9.53	HFQ-102F
54(6HP) < Q ≤ 86(9HP)	19.05	9.53	
86(9HP) < Q ≤ 114(12HP)	22.20	9.53	
114(12HP) < Q ≤ 154(16HP)	25.40	12.70	HFQ-162F
154(16HP) < Q ≤ 170(18HP)	28.60	12.70	
170(18HP) < Q ≤ 250(26HP)	28.60	15.88	HFQ-242F
250(26HP) < Q ≤ 324(34HP)	31.75	19.05	HFQ-302F
324(34HP) < Q ≤ 444(46HP)	38.10	19.05	
444(46HP) < Q ≤ 552(58HP)	41.30	22.20	HFQ-462F
552(58HP) < Q ≤ 654(68HP)	44.50	22.20	
654(68HP) < Q	50.80	25.40	HFQ-682F

NOTE:

Even if the equivalent refrigerant piping length (L1) is more than 100m, no need to increase the pipe size after first branch. If the branch pipe size is larger than the first branch, adjust the branch pipe size to the first branch. In case that the selected pipe size after the first branch is larger than the pipe size before the first branch, use the same pipe size as the one before the branch.

⑤ Pipe between last branch and indoor unit

1. The pipe diameter should be the same as the indoor unit piping connection size, details refer to the technical catalog of indoor unit.
2. When the liquid piping length is longer than 15m, use Φ9.53 pipe with reducer (field-supplied) instead of Φ6.35 pipe.

Piping Branch Restrictions

In the case that the piping length from the first branch to the farthest indoor unit (L2) is over 40m, follow the instructions below when performing the field-supplied piping work.

Example 1: Installation with Main Piping Branch

In the case that piping length from the first branch to the terminal indoor unit is within 40-90m.

- (1) If the piping length L2 is over 40m, the diameter of gas and liquid lines “b” and “c” or “g” and “h” should be increased by one size with reducers (field-supplied).
- (2) The difference between the piping length from the first branch to the farthest indoor unit and the piping length from the first branch to the nearest indoor unit must be within 40m.

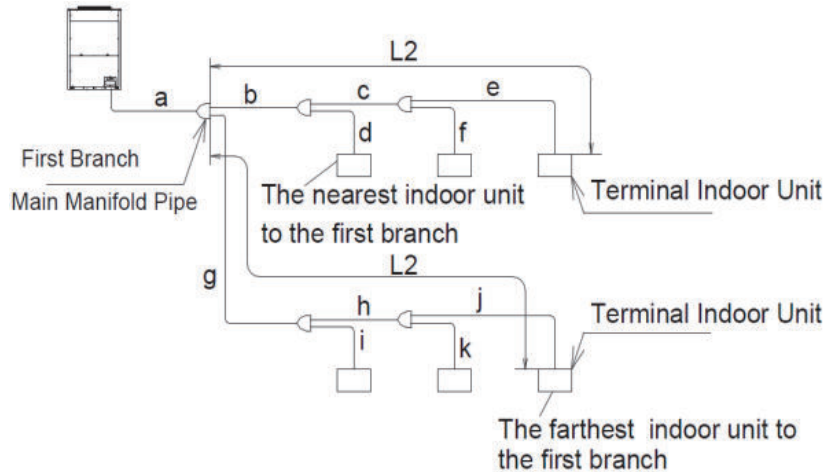

Example 2: Installation without Main Piping Branch

In the case that piping length from the first branch to the terminal indoor unit is within 40-90m.

- (1) If the piping length L2 is over 40m, the diameter of gas and liquid lines “b” and “d” and “f” should be increased by one size with reducers (field-supplied).
- (2) The difference between the piping length from the first branch to the farthest indoor unit and the piping length from the first branch to the nearest indoor unit must be within 40m.

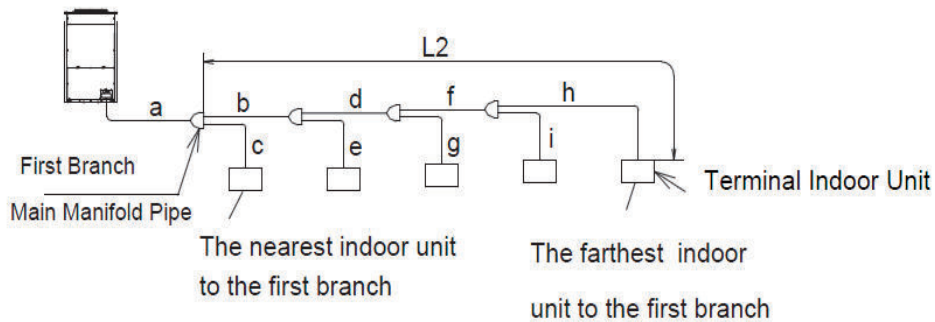

3.3 Calculation of Additional Refrigerant

Although refrigerant has been charged into this unit, additional refrigerant charge is required. Determine the additional refrigerant quantity according to the following procedure, and charge it into the system. Record the additional refrigerant quantity to facilitate maintenance and servicing activities thereafter.

1. Calculating Method of Additional Refrigerant Charge (W kg)

(1) Additional refrigerant charge calculation for liquid piping (W1)

Pipe Diameter Φ (mm)	Total Piping Length (m)	Refrigerant Amount for 1m Pipe (kg/m)	Additional Charge for liquid piping (kg)
28.6	m	×0.600=	
25.4	m	×0.480=	
22.2	m	×0.370=	
19.05	m	×0.260=	
15.88	m	×0.170=	
12.7	m	×0.110=	
9.53	m	×0.056=	
6.35	m	×0.024=	
Total Additional Charge For Liquid Piping (W1) =			

(2) Additional refrigerant charge calculation for indoor unit (W2)

Series	model	05	07	09	12	14	15	17	18	19	22	24	27(28)	30	38	48	54	76(96)	114	154	190
Ceiling Ducted Type (AC/DC Low-height)	AVE-*HCFRL; AVE-*HJFDL	0.12	0.12	0.21	0.21		0.26	0.26		0.36	0.38	0.38									
Ceiling Ducted Type (Low/High Static Pressure)	AVD-*HCFCL; AVD-*HCFCH		0.19	0.19	0.27		0.27			0.42	0.42	0.42	0.60	0.60	0.60	0.80	0.86	1.57			
Ceiling Ducted Type (DC Dynamic Static Pressure)	AVD-*HJFH		0.19	0.19	0.27		0.27			0.42		0.42		0.60	0.60	0.80	0.86	1.57			
1-way Cassette Type	AVY-*UXJSJA/KA		0.21	0.21	0.28	0.28			0.38			0.38									
2-way Cassette Type	AVL-*UXJSGA/HA		0.21	0.21	0.21	0.48			0.48			0.48	0.48	0.48	0.81	0.81	0.81				
4-Way Cassete Type	AVBC-*HJFKA			0.29	0.29		0.40			0.40	0.59	0.59	0.75	0.75	0.75	0.75	0.75				
Mini 4-Way Cassette	AVC-*HJFA	0.14	0.14	0.21	0.21		0.31	0.31		0.31											
Floor Concealed Type	AVH-*UXCSAA/BA			0.19		0.26			0.36			0.36									
Ceiling&Floor Type	AVV-*URSCA/B/C							0.42	0.42		0.42	0.42	0.58	0.58	0.58	0.75					
Console Type	AVK-*HJFCAA	0.13	0.20	0.20	0.29		0.29	0.29													
Wall Mounted Type	AVS-*HJFTDD, AVS-*HJFDJD	0.23	0.23	0.23	0.23		0.31		0.41			0.41	0.41								
All Fresh Air Indoor Unit	AVA-*UXCSCH/ QH/RH AVA-*UX6SRH/ SH/TH													0.40		0.91		1.57	1.57	2.59	3.06

According to the above table, the amount of additional refrigerant required for a single indoor unit of different models is found, and the amount of additional refrigerant W2 for indoor unit is the sum of all the additional refrigerant required for the indoor unit, but the maximum value of W2 is shown in the following table:

Capacity (kBtu/h)	76~308	326~386	402~544	556~618	634~696	714~816	824~928	946~1088
Max W2	6kg	8kg	10kg	12kg	14kg	16kg	19kg	21kg

(3) Additional refrigerant charge calculation for Connection Ratio (W3)

Connection Ratio (Total Capacity of Indoor Unit / Total Capacity of Outdoor Unit)	Refrigerant Charge (kg)
<100%	0.0
100% ~ 150%	0.5

(4) Total additional refrigerant charge can be calculated as follows: W=W1+W2+W3=_____kg

Maximum Additional Refrigerant Charge

Total additional charge must not exceed the maximum value indicated in the following table.

Once additional refrigerant charge exceeds the value below, total piping length should be reduced and recalculate the additional refrigerant charge to satisfy the table below.

Capacity (kBtu/h)	76 ~ 114	136 ~ 154	170 ~ 190	212 ~ 232	250 ~ 272	290 ~ 344	366 ~ 464	482 ~ 618	634 ~ 696	714 ~ 816	824 ~ 928	946 ~ 1088
Max. Additional Refrigerant Charge (kg)	24.0	31.0	34.0	38.0	39.0	50.0	53.0	68.0	73.0	80.0	90.0	100.0

Ref. Charge of O.U. before Shipment (W0)

Outdoor Unit	Outdoor Unit Ref. Charge (W0) kg
AVWT-76HKFXE	5.3
AVWT-96HKFXE	5.3
AVWT-114HKFXE	5.8
AVWT-136HKFXE	8.1
AVWT-154HKFXE	8.1
AVWT-170HKFXE	10.2
AVWT-190HKFXE	10.9
AVWT-212HKFXE	11.4
AVWT-232HKFXE	11.4
AVWT-250HKFXE	11.4
AVWT-272HKFXE	11.4

NOTES:

- W0 is outdoor unit ref. charge before shipment.
- In case of the combination of the basic unit, calculate the total ref. charge before shipment of the outdoor units to be combined.

2. Charging Work

Charge refrigerant (R410A) into the system according to Item 6.3. in INSTALLATION chapter

3. Record of Additional Charge

Total refrigerant charge of this system is calculated in the following formula.

Total Ref. Charge = W + W0

This System = + = kg

Total Additional Charge: W kg

Total Refrigerant Charge: kg

Date of Ref. / /

Charge Work:

3.4 Piping Connection Kit Dimensions (optional)

unit: mm

Models	Gas Line	Liquid Line	Reducer for Gas Line	Reducer for Liquid Line
HFQ-M22F			<p>(2 unit)</p>	—
HFQ-M32F			<p>(1 unit)</p> <p>(1 unit)</p> <p>(1 unit)</p>	—
HFQ-M462F			<p>(1 unit)</p> <p>(1 unit)</p>	<p>(1 unit)</p>
HFQ-M682F			<p>(1 unit)</p> <p>(1 unit)</p> <p>(2 unit)</p>	—

ID: Inner Diameter, OD: Outer Diameter

unit: mm

Models	Gas Line	Liquid Line	Reducer for Gas Line	Reducer for Liquid Line	
HFQ-102F	<p>Diagram showing gas line connections with dimensions: ID15.88, ID12.7, ID19.05, ID22.2, ID15.88, ID12.7, ID19.05, ID22.2, ID15.88, ID12.7.</p>	<p>Diagram showing liquid line connections with dimensions: ID12.7, ID9.53, ID9.53, ID6.35, ID9.53, ID6.35, ID9.53, ID6.35.</p>	/	<p>Diagram showing a reducer for liquid line with dimensions: ID9.53, OD6.35.</p>	
HFQ-162F	<p>Diagram showing gas line connections with dimensions: ID25.4, ID28.6, ID25.4, ID28.6, ID25.4, ID22.2, ID22.2, ID15.88, ID19.05, ID12.7.</p>	<p>Diagram showing liquid line connections with dimensions: ID12.7, ID9.53, ID9.53, ID12.7, ID9.53, ID12.7, ID9.53, ID6.35.</p>		<p>Diagram showing a reducer for gas line with dimensions: OD25.4, ID15.88, ID12.7, ID22.2, ID19.05.</p>	<p>Diagram showing a reducer for liquid line with dimensions: ID9.53, OD6.35.</p>
HFQ-242F	<p>Diagram showing gas line connections with dimensions: ID25.4, ID28.6, ID25.4, ID28.6, ID25.4, ID22.2, ID22.2, ID15.88, ID19.05, ID12.7.</p>	<p>Diagram showing liquid line connections with dimensions: ID9.53, ID12.7, ID15.88, ID15.88, ID19.05, ID15.88, ID12.7, ID9.53, ID6.35.</p>		<p>Diagram showing a reducer for gas line with dimensions: OD25.4, ID15.88, ID12.7, ID22.2, ID19.05.</p>	<p>Diagram showing a reducer for liquid line with dimensions: ID9.53, OD6.35.</p>
HFQ-302F	<p>Diagram showing gas line connections with dimensions: ID31.75, ID32.0, ID38.1, ID31.75, ID31.75, ID28.6, ID28.6.</p>	<p>Diagram showing liquid line connections with dimensions: ID22.2, ID19.05, ID25.4, ID15.88, ID12.7, ID9.53, ID19.05, ID22.2, ID25.4, ID15.88, ID9.53, ID12.7, ID6.35.</p>		<p>Diagram showing a reducer for gas line with dimensions: OD31.75, ID22.2, ID28.6.</p>	<p>Diagram showing a reducer for liquid line with dimensions: ID9.53, OD6.35.</p>
			<p>Diagram showing a reducer for gas line with dimensions: OD28.6, ID15.88, ID12.7, ID22.2, ID19.05.</p>		
			<p>Diagram showing a reducer for gas line with dimensions: OD38.1, ID34.92.</p>		

ID: Inner Diameter, OD: Outer Diameter

unit: mm

Models	Gas Line	Liquid Line	Reducer for Gas Line	Reducer for Liquid Line
HFQ-462F			<p>(1 unit)</p>	<p>(1 unit)</p>
			<p>(2 unit)</p>	
HFQ-682F			<p>(1 unit)</p>	<p>(1 unit)</p>
			<p>(2 unit)</p>	
			<p>(2 unit)</p>	<p>(2 unit)</p>
			<p>(1 unit)</p>	

ID: Inner Diameter, OD: Outer Diameter

4. Capacities and Selection Data

4.1 Procedure for Selection of the System

This section explains the procedure to select the most suitable outdoor unit, with the values to be taken into account and the necessary steps to be carried out.

This procedure allows to select the unit with the best characteristics to provide the greatest level of efficiency and comfort, considering the building layout, the specifications of the indoor units to be installed and the distribution of air and refrigerant flows.

The ease of access for installation and maintenance work must be taken into account when selecting the location for installation of the outdoor unit.

4.1.1 Unique Features of the System

The system boasts some unique features that must be taken into account before selecting the outdoor unit.

Possibility of installing a reduced total unit capacity

The system allows the connection of a total combined indoor capacity as low as 50% and as high as 150%, of the nominal capacity of the outdoor unit. In comparison with other air conditioning systems requiring the indoor and outdoor nominal capacities to be equal, the system allows the installation of an outdoor unit with a nominal capacity up to 50% smaller than the total combined indoor capacity. This possibility is explained in the following example:

The diagram shows a typical building with a morning peak heat load on the east zone equivalent to a 68,500 Btu/h unit. In the afternoon, a peak equivalent to a 78,400 Btu/h unit occurs on the west zone.

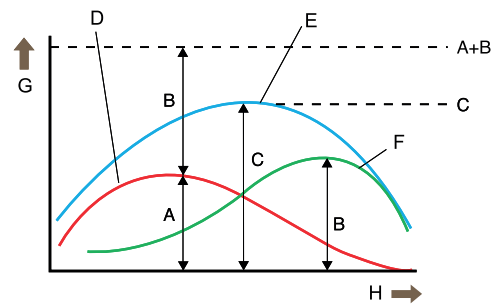
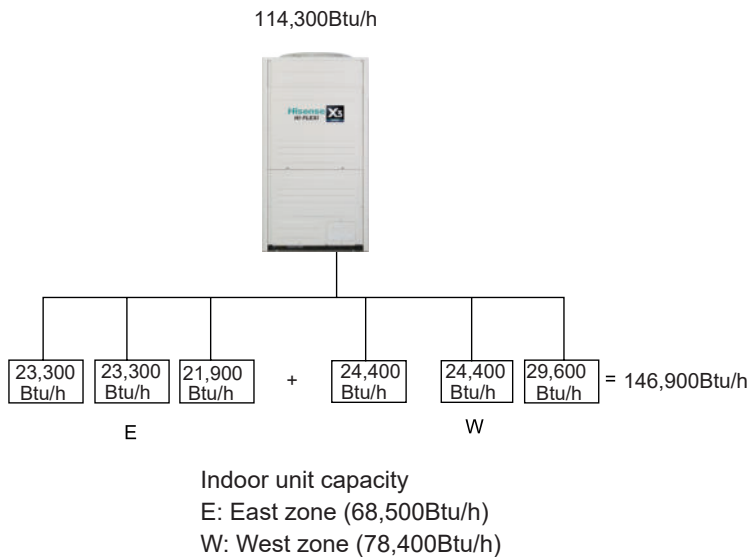

- A: morning peak heat load in the eastern area
- B: evening peak heat load in the western area
- C: maximum simultaneous load for the entire building
- D: eastern area load
- E: total load
- F: western area load
- G: load
- H: time

In this case, a conventional system would require the installation of a 146,900 Btu/h outdoor unit, matching the total installed indoor capacity (68,500 Btu/h + 78,400 Btu/h). However, the maximum simultaneous load in the whole building occurs at noon, and is equal to 114,300 Btu/h of unit capacity. Therefore, a 114,300 Btu/h outdoor unit could be selected, directing its capacity to either the east or the west zone as dictated by the system controls.

NOTES:

- The maximum required loads of east and west zone must not be simultaneous.
- In systems in which all the indoor units are operated simultaneously, the total indoor capacity must not exceed the nominal capacity of the outdoor unit. Otherwise, poor performance or a narrowing of the operation range in overload conditions may occur.

The ratio of total combined horsepower is calculated with the following formula:

$$\text{Ratio of total combined horsepower} = \left(\frac{\text{Total capacity of the indoor units}}{\text{Capacity of the outdoor unit}} \right) \times 100\% = \left(\frac{146,900 \text{ Btu/h}}{114,300 \text{ Btu/h}} \right) \times 100\% \approx 126\%$$

4.1.2 Selection Parameters

To select the outdoor units, it will be necessary to consult and/or use a series of parameters shown in tables and graphics presented in the different chapters of this handbook. A summarized list is shown below:

For cooling and heating capacities: manual of Engineering Data.

For cooling correction factor depending on the piping length: 4.2 “Capacity Correction Based on Refrigerant Piping Length”.

For heating correction factor depending on the piping length: 4.2 “Capacity Correction Based on Refrigerant Piping Length”.

For sensible heat factor: VRF Indoor Units Technical Catalog.

In case of an installation with ducts (outdoor unit with AVD indoor unit) the fan performance for duct calculations should be considered. The AVD units are designed with difference static pressure ranges in order to fulfill all installation necessities.

4.1.3 Check Points for System Installation

For selecting the unit capacity, perform the system selection with checking the refrigerant concentration at leakage in order not to exceed the maximum permissible concentration.

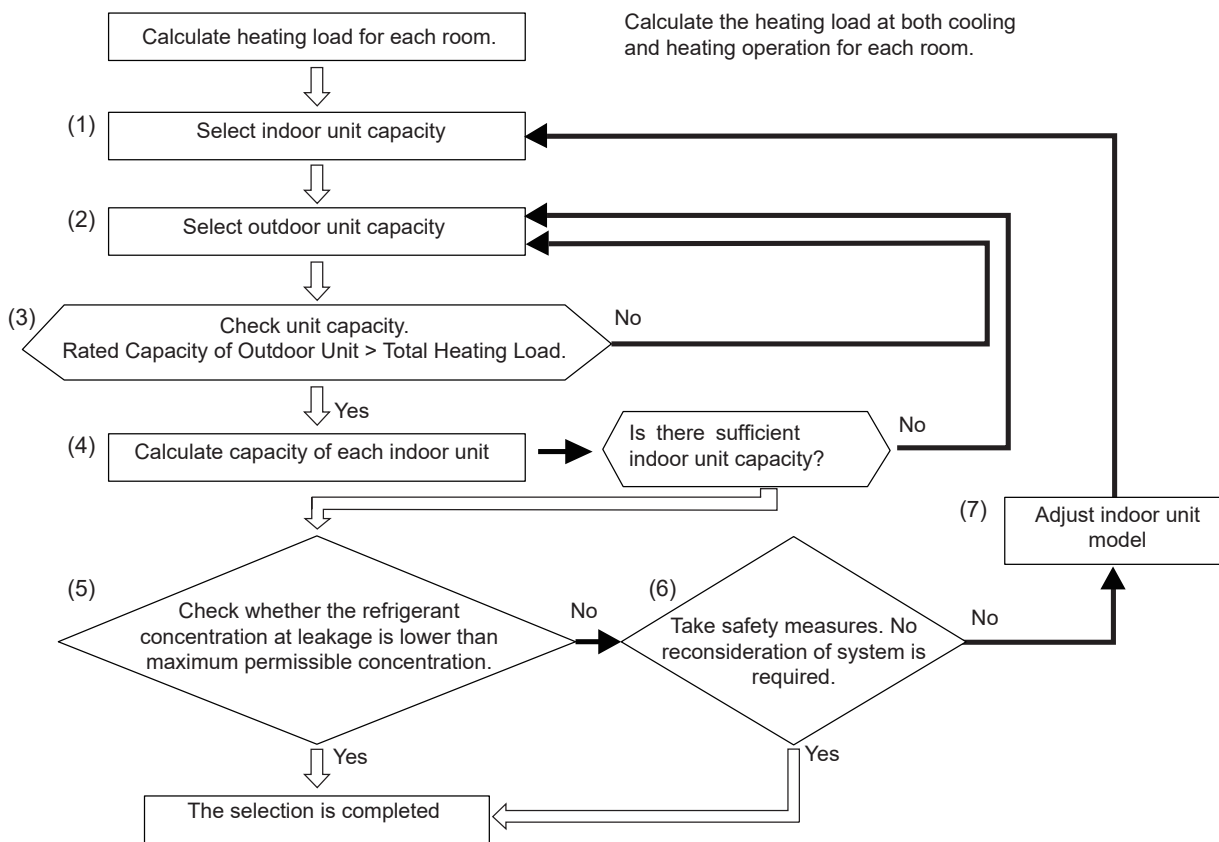

(1) Selecting indoor unit capacity.

Set temporarily the indoor unit model and capacity in each room as following:

$$\text{Heating Load for each room} < \text{Capacity of Indoor Unit}$$

At this time, consider the correction factor according to room temperature.

Then, sum up each indoor unit capacity (The calculation is required for cooling and heating operation).

$$\text{Indoor unit capacity} = \text{Rated capacity} \times \text{correction Factor (room temperature)}$$

Correction factor according to room temperature: When the estimated load for each room differs from the rated capacity (cooling: 27 °C DB/19 °C WB; heating: 20°C DB, select the outdoor unit capacity at the estimated load from the manual of Engineering Data.

$$\text{Correction Factor (room temperature)} = \text{Outdoor unit capacity at estimated load} / \text{Rated outdoor unit capacity}$$

(2) Selecting outdoor unit capacity.

Set temporarily the outdoor unit capacity according to the total connectable indoor unit capacity at the item (1). Then, calculate maximum outdoor unit capacity with considering the correction factors according to temperature condition, piping length and lift, and defrosting correction factor (for heating operation). The calculation is required for cooling and heating operation

$$\text{Outdoor unit capacity} = \text{Outdoor unit capacity at estimated load} \times \text{Correction factors (total indoor unit capacity, piping length, defrosting correction factor (for heating operation))}$$

Outdoor unit capacity at estimated load: When calculating heating load for outdoor unit, check the ambient temperature.

If the ambient temperature differs from the temperature indicated in the rated capacity (cooling: 35°C DB; heating: 7°C DB / 6°C WB), select the outdoor unit capacity at the estimated load from the manual of Engineering Data.

Correction factor according to total indoor unit capacity:

- Select the correction factor according to manual of Engineering Data.
- Correction factor according to piping length:
- Select the correction factor according to 4.2 "Capacity Correction Based on Refrigerant Piping Length".
- Correction factor according to defrosting condition (for heating operation):
- Select the correction factor according to 4.3 "Correction Factor According to Defrosting Operation".

(3) Checking unit capacity.

Compare the outdoor unit capacity calculated in the item (2) with the total heating load.

(4) Calculating each indoor unit capacity.

Recalculate the indoor unit capacity as follows. (The calculation is required for cooling and heating operation.)

$$\text{Unit capacity for each room} = \frac{\text{Outdoor Unit Capacity (value at item 2)} \times (\text{indoor unit capacity in concerned room (model)})}{\text{Total indoor unit capacity (model)}}$$

If the outdoor unit capacity is insufficient against the necessary heating load for each room, recalculate it from the item (2) after the outdoor unit capacity is increased.

(5) Checking Refrigerant Concentration at Refrigerant Leakage < Permissible Refrigerant Concentration.

(6) Taking Safety Measure (Reconsideration of system is not required.)

(7) Correction of outdoor unit model if the condition of both (5) and (6) are negative.

NOTES:

- Refer to 6.3 Charging Operation in Installation Chapter for items from (5) through (7).
- When the temperature is set, consider that the ambient temperature increases by short circuit. Especially, if multiple outdoor units are installed or there is obstacle around the outdoor unit, pay attention to increase the ambient temperature.
- For the setting temperature at the heating operation in the ducted and cassette indoor unit type, consider the temperature irregularity between the floor and the ceiling surface. The temperature around the ceiling surface normally becomes 2°C higher than the floor surface during the heating operation.
- For selecting indoor unit capacity, if the sensible heating load is considered, consider the sensible heat factor together.
- In the case that the total indoor unit capacity exceeds the outdoor unit capacity, the temperature is low or the piping length is long, if the indoor units operate simultaneously, the air outlet temperature decreases so that affects comfort level. Therefore, the facility should be designed that the cooling/heating capacity for indoor unit calculated from the cooling/heating capacity for system is more than the heating load.

4.1.4 Selection procedure example

Given conditions

Once considered the system possibilities, it's the moment to start with the selection procedure. In order to do this, it has been assumed an installation consisting of several rooms with different required cooling loads and temperature conditions.

Total load required for each room

Concept	Room 1	Room 2	Room 3	Room 4	Room 5	Room 6	Room 7
Estimated cooling load (Btu/h)	13,470	17,250	17,250	20,700	27,930	30,760	30,760
Estimated heating load (Btu/h)	14,590	18,620	18,620	22,410	29,440	32,050	32,050

Temperature condition

Operating conditions		Cooling	Heating
Indoor air inlet temperature	DB	27.0	20.0
	WB	19.0	—
Outdoor air inlet temperature	DB	30.0	1.0
	WB	—	0.0

DB: dry bulb; WB: wet bulb.

Piping connection conditions:

- Equivalent pipe length between outdoor unit and indoor units: 60 m.
- Pipe height: 25 m.

In this example, the maximum required loads will not be simultaneous.

Appropriate selection of indoor units and nominal capacity

Example: selection of AVD ducted indoor units.

The pre-selected capacity of the different indoor units has not been the immediately higher in all the units, in order to apply safety factor considering the different correction factors existing, which will reduce the capacity.

Concept	Room 1	Room 2	Room 3	Room 4	Room 5	Room 6	Room 7
Model selected	AVD-19*	AVD-24*	AVD-24*	AVD-27*	AVD-38*	AVD-48*	AVD-48*
Nominal cooling load (Btu/h)	19,100	24,200	24,200	27,400	38,000	48,000	48,000
Nominal heating load (Btu/h)	21,600	27,400	27,400	30,800	42,500	54,500	54,500

Then, it's shown a diagram of the installation resulting: 191,100Btu/h

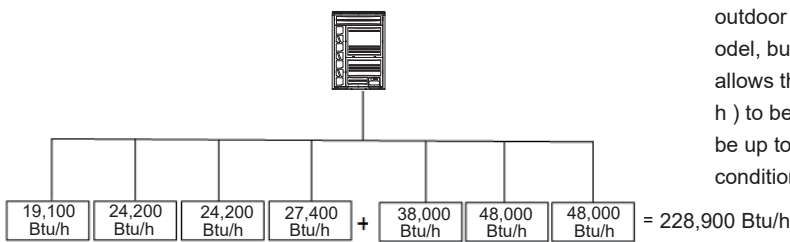

The resulting total indoor unit capacity is 228,900 Btu/h. The outdoor unit with the exact capacity is the 228,900 Btu/h model, but the possibility "Reduced total outdoor unit capacity" allows the AVWT-190* model (nominal capacity: 191,100 Btu/h) to be selected. Thus, it is allowed that the outdoor unit to be up to 20% smaller capacity when compared with other air conditioning systems.

$$\text{Total combination horsepower} = (\text{Total indoor unit capacity} / \text{Outdoor unit capacity}) \times 100\% = (228,900 \text{ Btu/h} / 191,100 \text{ Btu/h}) \times 100\% \approx 120\%$$

NOTE:

The maximum simultaneous load on the installation must not be higher than 191,100 Btu/h for this example.

To determine the outdoor unit pre-selected nominal cooling and heating capacity, it's necessary refer to Engineering Data, in which the total capacity combination (120%) and the temperature condition have been taken into consideration.

Concept	Room 1+2+3+4+5+6+7	Outdoor unit pre-selected capacity(AVWT-190*~120%)
Total nominal cooling load (Btu/h)	228,900	204,105
Total nominal heating load (Btu/h)	258,700	222,462

NOTES:

- If the air inlet temperature for the indoor unit or outdoor unit is not contained in the capacity tables, an interpolation should be carried out using the values above and below the air inlet temperature.
- If the total combination capacity is not shown in the capacity tables (for example, 115%), an interpolation should be carried out using the values above and below (110% and 120%) the total combination.

Next step will be the capacity correction using the different correction factors shown in this chapter.

Correction factor according to piping length:

According to 4.2 “Capacity Correction Based on Refrigerant Piping Length”.

- Cooling capacity correction factor depending on the pipe length =0.890.
- Heating capacity correction factor depending on the pipe length =0.954.

Correction factor according to defrosting condition (for heating operation):

According to 4.3 “Correction Factor According to Defrosting Operation”.

- Outdoor inlet air temp.(°C DB)=1, then Defrost correction factor = 0.857.

Actual capacity of the outdoor unit

$$\text{Actual maximum capacity of the outdoor unit} = (\text{Nominal capacity of the outdoor unit}) \times (\text{Correction factor according to pipe length and height}) \times (\text{Correction factor according to temperature})$$

Cooling: $(204,105 \text{ Btu/h}) \times (0.890) \times (1.0) = 181,653 \text{ Btu/h}$.

Heating: $(222,462 \text{ Btu/h}) \times (0.954) \times (0.857) = 181,880 \text{ Btu/h}$.

Actual capacity of each indoor unit.

$$\text{Actual capacity of each indoor unit} = (\text{Actual capacity of the outdoor unit}) \times (\text{Nominal capacity of each indoor units} / \text{Total nominal capacity of each indoor unit})$$

Example:

AVD-19*

Cooling: $181,653 \times (19,100 / (19,100 + 24,200 + 24,200 + 27,400 + 38,000 + 48,000 + 48,000)) = 15,158 \text{ Btu/h}$.

Heating: $181,880 \times (21,600 / (21,600 + 27,400 + 27,400 + 30,800 + 42,500 + 54,500 + 54,500)) = 15,186 \text{ Btu/h}$.

AVD-24*

Cooling: $181,653 \times (24,200 / (19,100 + 24,200 + 24,200 + 27,400 + 38,000 + 48,000 + 48,000)) = 19,208 \text{ Btu/h}$.

Heating: $181,880 \times (27,400 / (21,600 + 27,400 + 27,400 + 30,800 + 42,500 + 54,500 + 54,500)) = 19,264 \text{ Btu/h}$.

AVD-27*

Cooling: $181,653 \times (27,400 / (19,100 + 24,200 + 24,200 + 27,400 + 38,000 + 48,000 + 48,000)) = 21,744 \text{ Btu/h}$.

Heating: $181,880 \times (30,800 / (21,600 + 27,400 + 27,400 + 30,800 + 42,500 + 54,500 + 54,500)) = 21,654 \text{ Btu/h}$.

AVD-38*

Cooling: $181,653 \times (38,000 / (19,100 + 24,200 + 24,200 + 27,400 + 38,000 + 48,000 + 48,000)) = 30,156 \text{ Btu/h}$.

Heating: $181,880 \times (42,500 / (21,600 + 27,400 + 27,400 + 30,800 + 42,500 + 54,500 + 54,500)) = 29,880 \text{ Btu/h}$.

AVD-48*

Cooling: $181,653 \times (48,000 / (19,100 + 24,200 + 24,200 + 27,400 + 38,000 + 48,000 + 48,000)) = 38,092 \text{ Btu/h}$.

Heating: $181,880 \times (54,500 / (21,600 + 27,400 + 27,400 + 30,800 + 42,500 + 54,500 + 54,500)) = 38,316 \text{ Btu/h}$.

Results:

Concept	Room 1	Room 2	Room 3	Room 4	Room 5	Room 6	Room 7
Model selected	AVD-19*	AVD-24*	AVD-24*	AVD-27*	AVD-38*	AVD-48*	AVD-48*
Actual cooling capacity (Btu/h)	15,158	19,208	19,208	21,744	30,156	38,092	38,092
Actual heating capacity (Btu/h)	15,186	19,264	19,264	21,654	29,880	38,316	38,316
Estimated cooling load (Btu/h)	13,470	17,250	17,250	20,700	27,930	30,760	30,760
Estimated heating load (Btu/h)	14,590	18,620	18,620	22,410	29,440	32,050	32,050

Concept	Room 1+2+3+4+5+6+7
Actual total cooling capacity (Btu/h)	181,653
Actual total heating capacity (Btu/h)	181,880
Estimated total cooling load (Btu/h)	158,120
Estimated total heating load (Btu/h)	167,780

As can be seen, the actual total cooling and heating capacity are higher than the estimated total cooling and heating load.

Therefore, it can be said that the AVWT-190* unit meets the minimum cooling and heating requirements set for the system.

NOTES:

If the actual total cooling / heating capacity calculated is lower than the estimated total cooling / heating load, the calculation must be done again with the unit immediately.

4.2 Capacity Correction Based on Refrigerant Piping Length

< Cooling Capacity >

Correction factor for cooling capacity according to piping length.

The correction factors are shown in the following figure.

The cooling capacity should be corrected according to the following formula:

$$CCA = CC \times F$$

CCA: actual corrected cooling capacity

CC: cooling capacity in the performance table

F: correction factor based on the equivalent piping length

Equivalent piping length for

- one 90° elbow is 0.5m.
- one 180° bend is 1.5m.
- one branch pipe is 0.5m

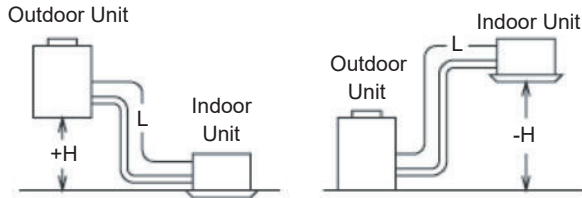

H: Vertical Distance Between Indoor Unit and Outdoor Unit

EL: Equivalent Total Distance Between Indoor Unit and Outdoor Unit (Equivalent One-Way Piping Length)

H>0: Position of Outdoor Unit Higher Than Position of Indoor Unit

L: Actual One-Way Piping Length Between Indoor Unit and Outdoor Unit

* H and EL please refer to INSTALLATION Chapter Section 4 Refrigerant Piping Work

AVWT-76*~1088*

— Normal
 - - Size up

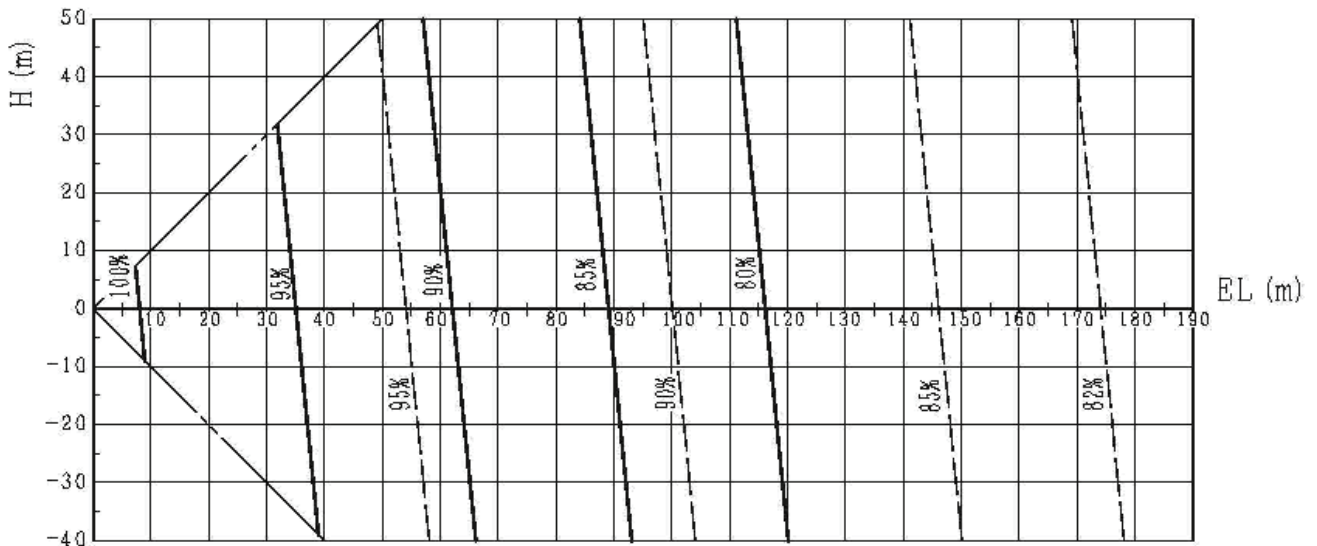

<Heating Capacity >

Correction factor for heating capacity according to piping length.

The correction factors are shown in the following figure.

The heating capacity should be corrected according to the following formula:

$$HCA=HC \times F$$

HCA: actual corrected heating capacity

HC: heating capacity in the performance table

F: correction factor based on the equivalent piping length

Equivalent Piping Length for

- one 90° elbow is 0.5m.
- one 180° bend is 1.5m.
- one branch pipe is 0.5m

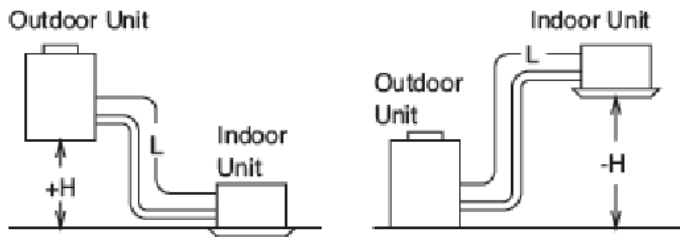

H: vertical distance between indoor unit and outdoor unit in meters

EL: equivalent total distance between indoor unit and outdoor unit in meters.

(equivalent one-way piping length)

H>0: position of outdoor unit higher than position of Indoor unit

L: actual one-way piping length between indoor unit and outdoor unit in meters

* H and EL please refer to INSTALLATION Chapter Section 4 Refrigerant Piping Work

AVWT-76*~1088*

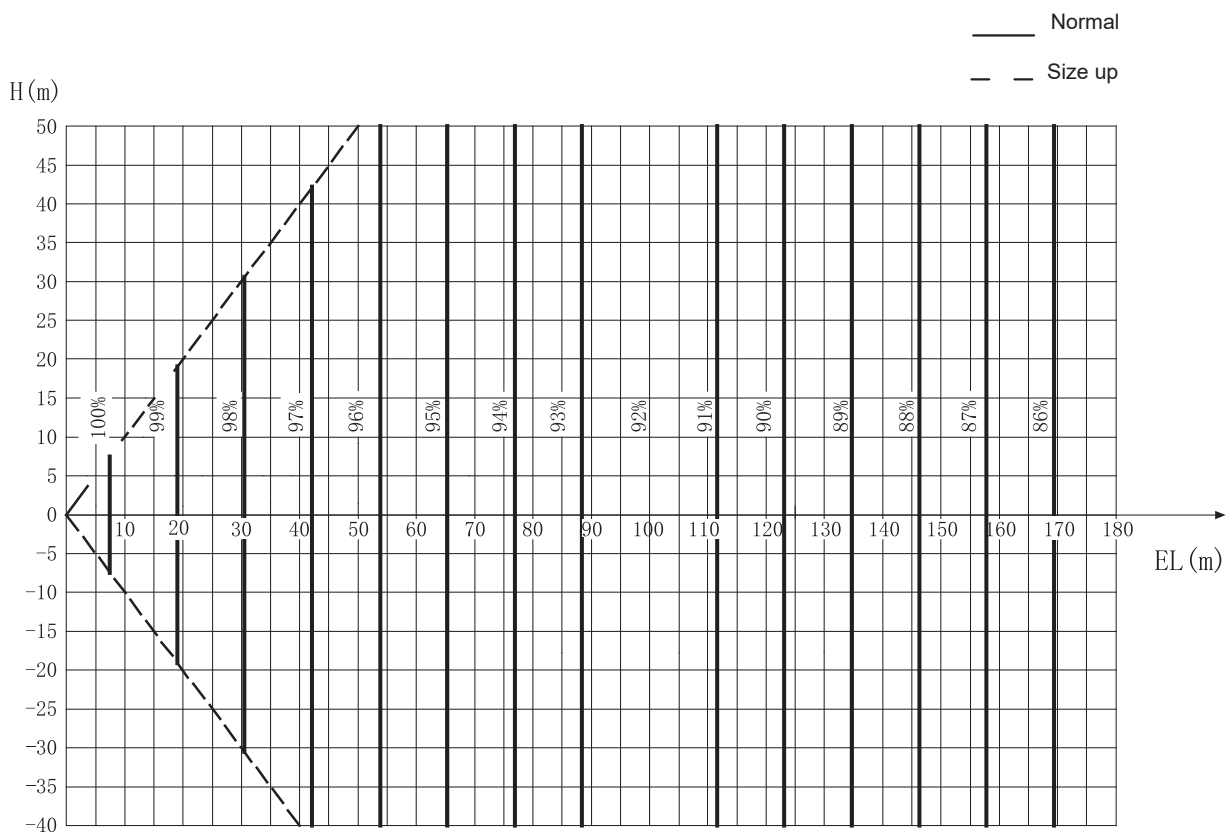

4.3 Correction Factor According to Defrosting Operation

The heating capacity in the preceding paragraph excludes the condition of the frost or the defrosting operation period.

In consideration of the frost or the defrosting operation, the heating capacity is corrected by the equation below.

Corrected Heating Capacity = Correction Factor × Heating Capacity.

Outdoor Inlet Air Temp. (°C DB) (Humidity=85% RH)	-7	-5	-3	0	3	5	7
Correction Factor	0.95	0.93	0.88	0.85	0.87	0.90	1.0

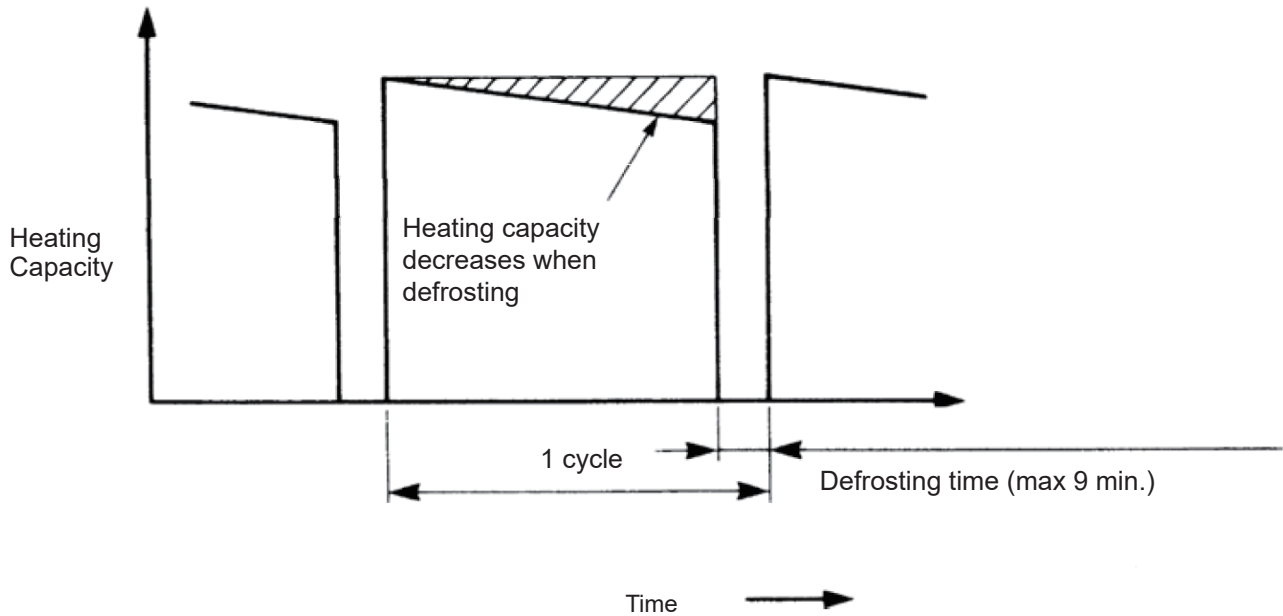

NOTE:

The correction factor is not available for the special condition like a snowfall or an operation in a transitional period.

5. Control System

5.1 Refrigerant Cycle

AVWT-76~170HKFXE

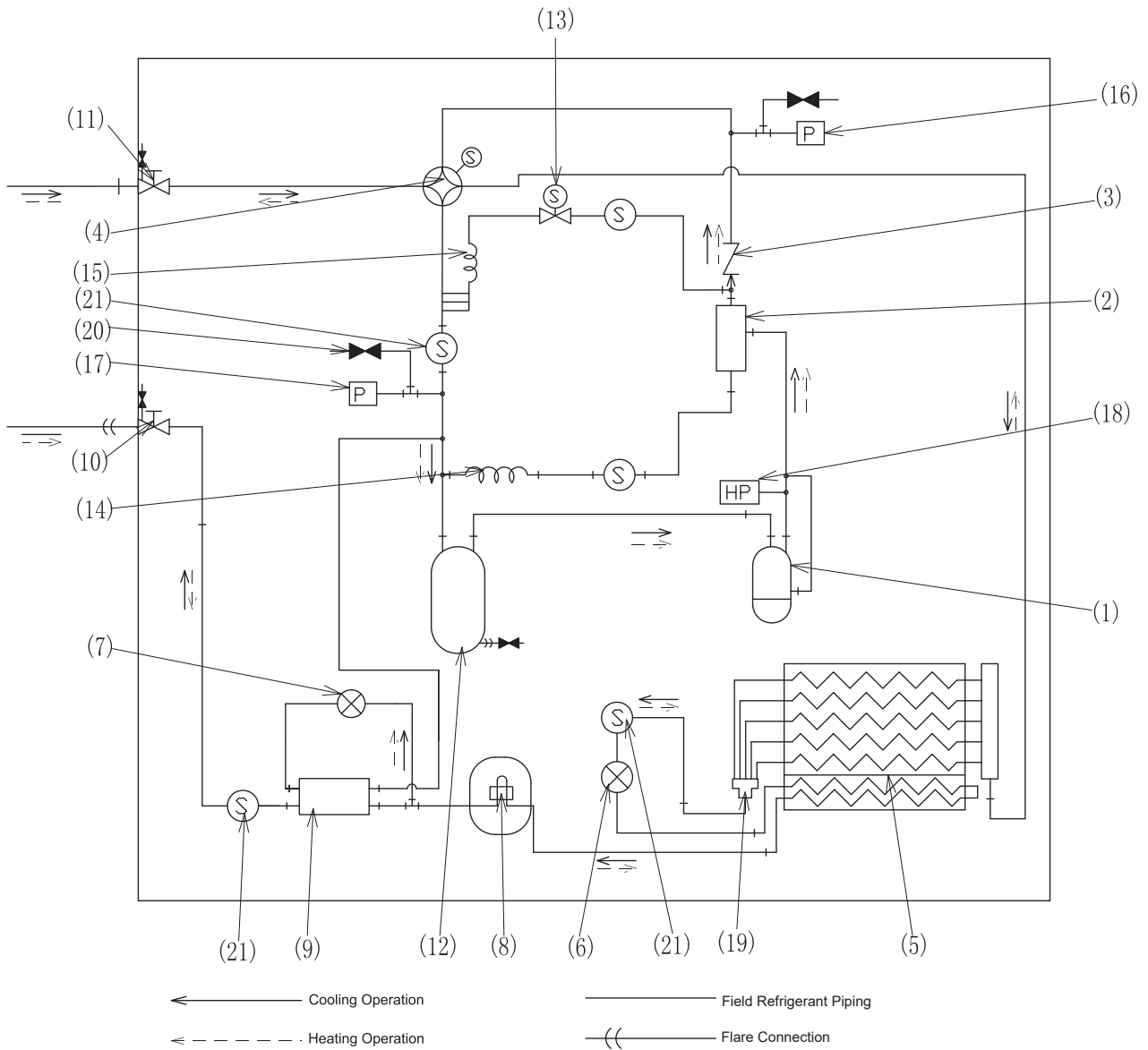

NO.	Name	NO.	Name	
1	Compressor	12	Accumulator	
2	Oil separator	13	Solenoid valve	SVA
3	Check valve	14	Capillary tube	SVF
4	4-way reversing valve	15	Capillary tube	SVA
5	Heat exchanger	16	Pressure sensor	HP
6	Expansion valve	17	Pressure sensor	LP
7				
8	Refrigerant cooler	18	Pressure switch(high)	
9	Subcooler	19	Distributor	
10	Stop valve	20	Check Joint	
11			21	Strainer

AVWT-190~272HKFXE

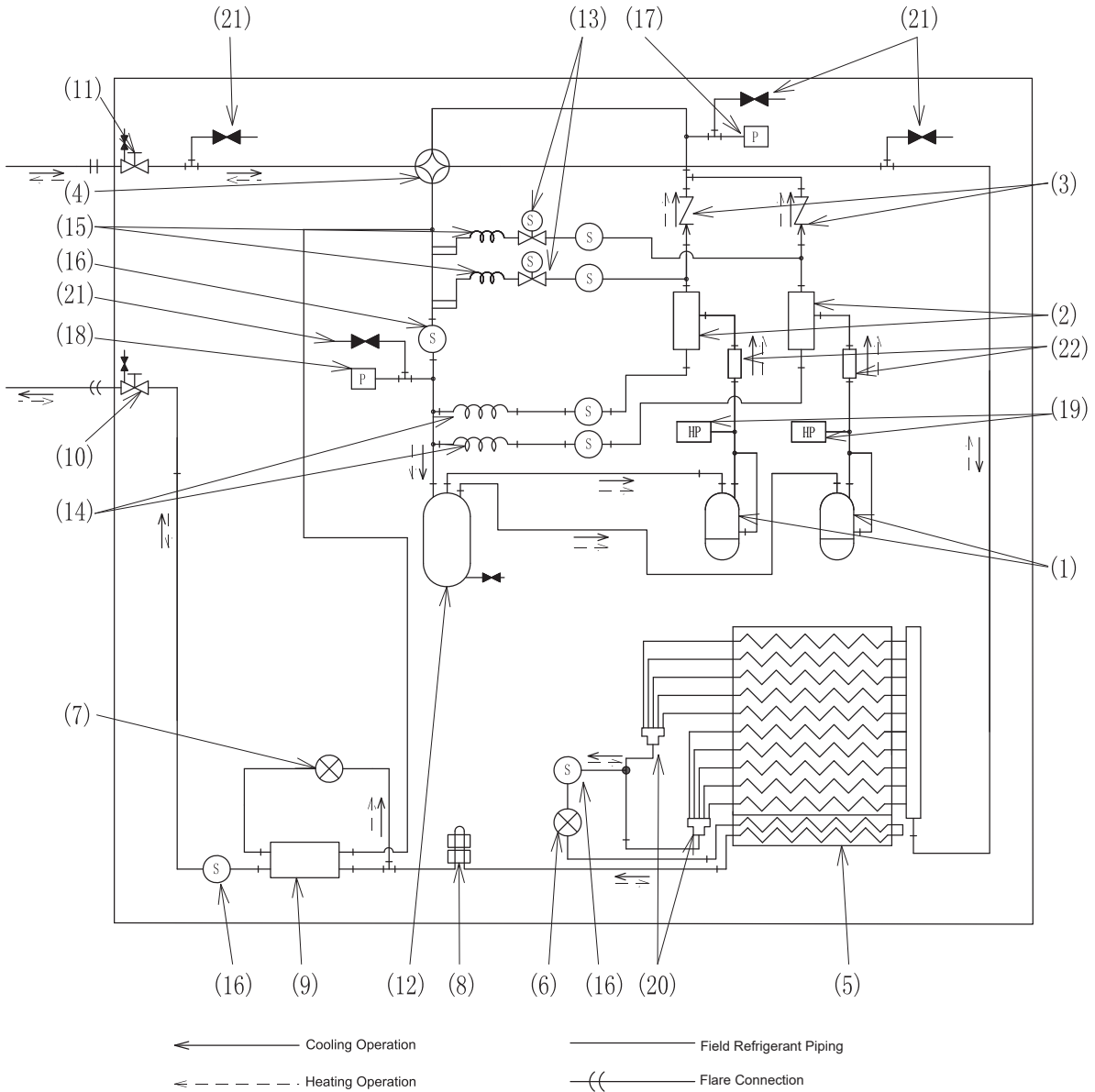

NO.	Name	NO.	Name		
1	Compressor	12	Accumulator		
2	Oil separator	13	Solenoid valve	SVA	
3	Check valve	14	Capillary tube	SVF	
4	4-way reversing valve	15	Capillary tube	SVA	
5	Heat exchanger	16	Strainer		
6	Expansion valve	EVO	17	Pressure sensor	HP
7		EVB	18	Pressure sensor	LP
8	Refrigerant cooler	19	Pressure switch(high)		
9	Subcooler	20	Distributor		
10	Stop valve	liquid	21	Check Joint	
11		gas			

5.2 Control Logic

Table 5.1 Cycle Control

Control Device		Summary of Control			
		Cooling Operation*		Heating Operation	
		Purpose of Control	Contents of Control	Purpose of Control	Contents of Control
MC	Inverter Frequency of Compressor	Cooling Capacity Control	Inverter Frequency Control is carried out to bring the I.U. air inlet temperature to temperature setpoint by evaporation temperature control.	Heating Capacity Control	Inverter Frequency Control is carried out to bring the I.U. air inlet temperature to temperature setpoint by condensation temperature control..
EVO	Electronic Expansion Valve for HEX	HEX SC Control	EVO opening is adjusted to achieve the target value of HEX SC.	HEX SH Control	EVO opening is adjusted to achieve the target value of HEX SH.
EVB	Electronic Expansion Valve for plate Type HEX	Compressor discharge temperature and SC of liquid refrigerant	EVB opening is adjusted to achieve the target value of compressor discharge temperature and SC of liquid refrigerant	Compressor discharge temperature and SC of liquid refrigerant	EVB opening is adjusted to achieve the target value of compressor discharge temperature and SC of liquid refrigerant
EVI	Electronic Expansion Valve for Indoor Unit	I.U. HEX SH Control	EVI opening is adjusted to achieve the target value of I.U. HEX SH.	I.U. HEX SC Control	EVI opening is adjusted to achieve the target value of I.U. HEX SC.
SVA	Solenoid Valve to Bypass High/Low Pressure	1. Pd Increase Protection 2. Ps Decrease Protection	1. Pd> 3.7MPa: Open 2. Ps< 0.2MPa: Open	1. Pd Increase Protection 2. Ps Decrease Protection	1. Pd> 3.5MPa: Open 2. Ps< 0.17MPa: Open

(*): Dry operation is included in the cooling operation.

- Pd: Discharge Pressure
- Ps: Suction Pressure
- SH: Superheat
- SC: Subcool
- I.U.: Indoor Unit
- HEX: Heat Exchanger

5.3 Standard Operation Procedure Chart

Cooling operation

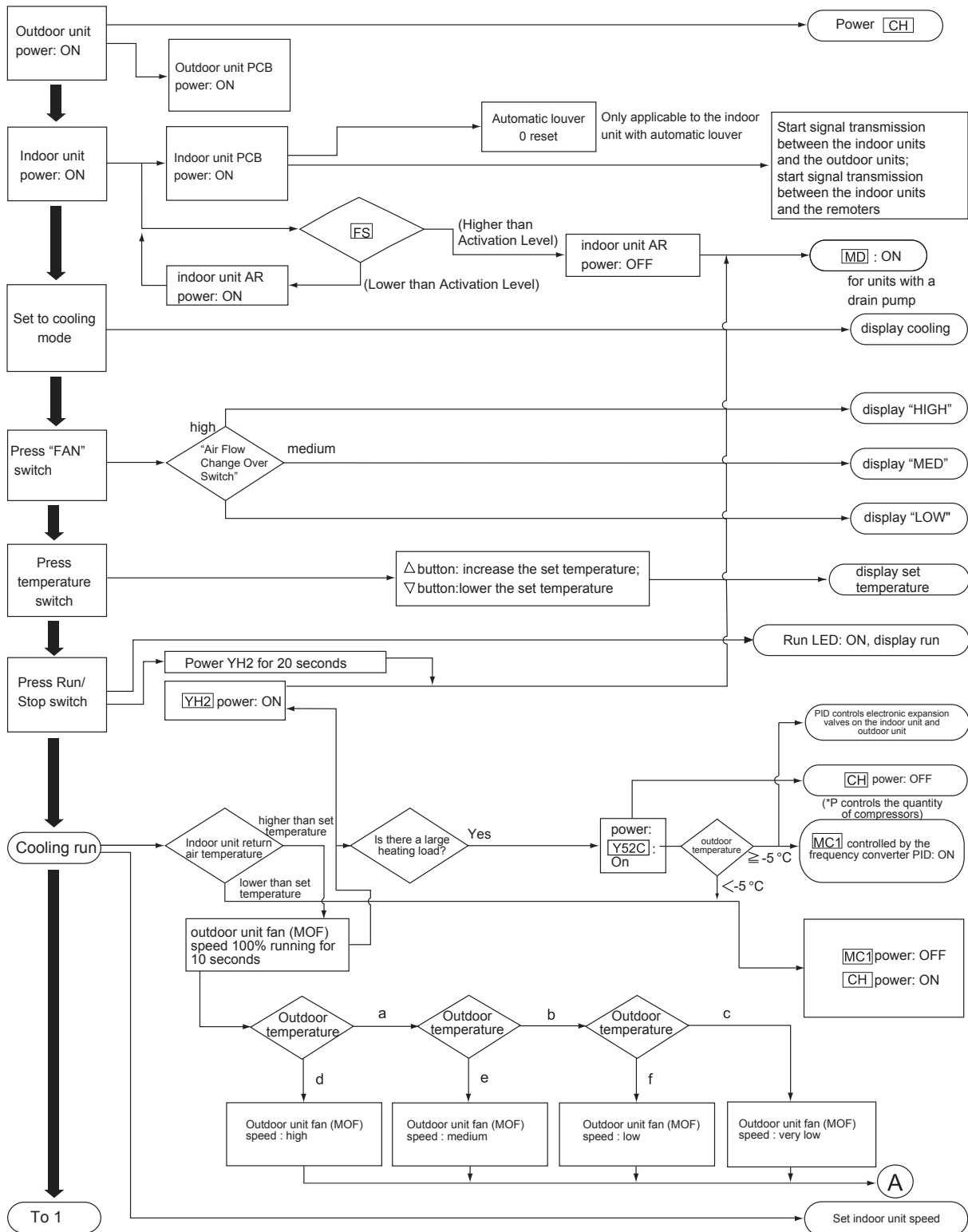

a	b	c	d	e	f
Lower than 25°C	Lower than 18°C	Lower than 11°C	Higher than 25°C	Higher than 18°C	Higher than 11°C

Cooling operation

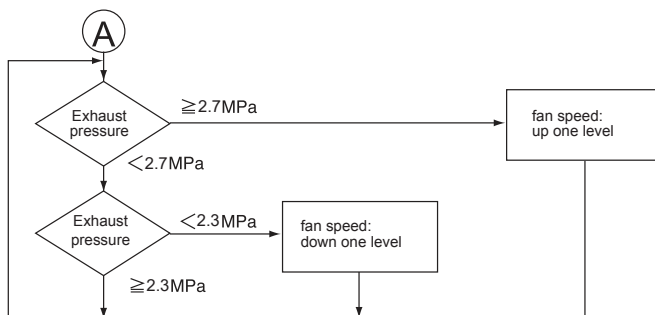
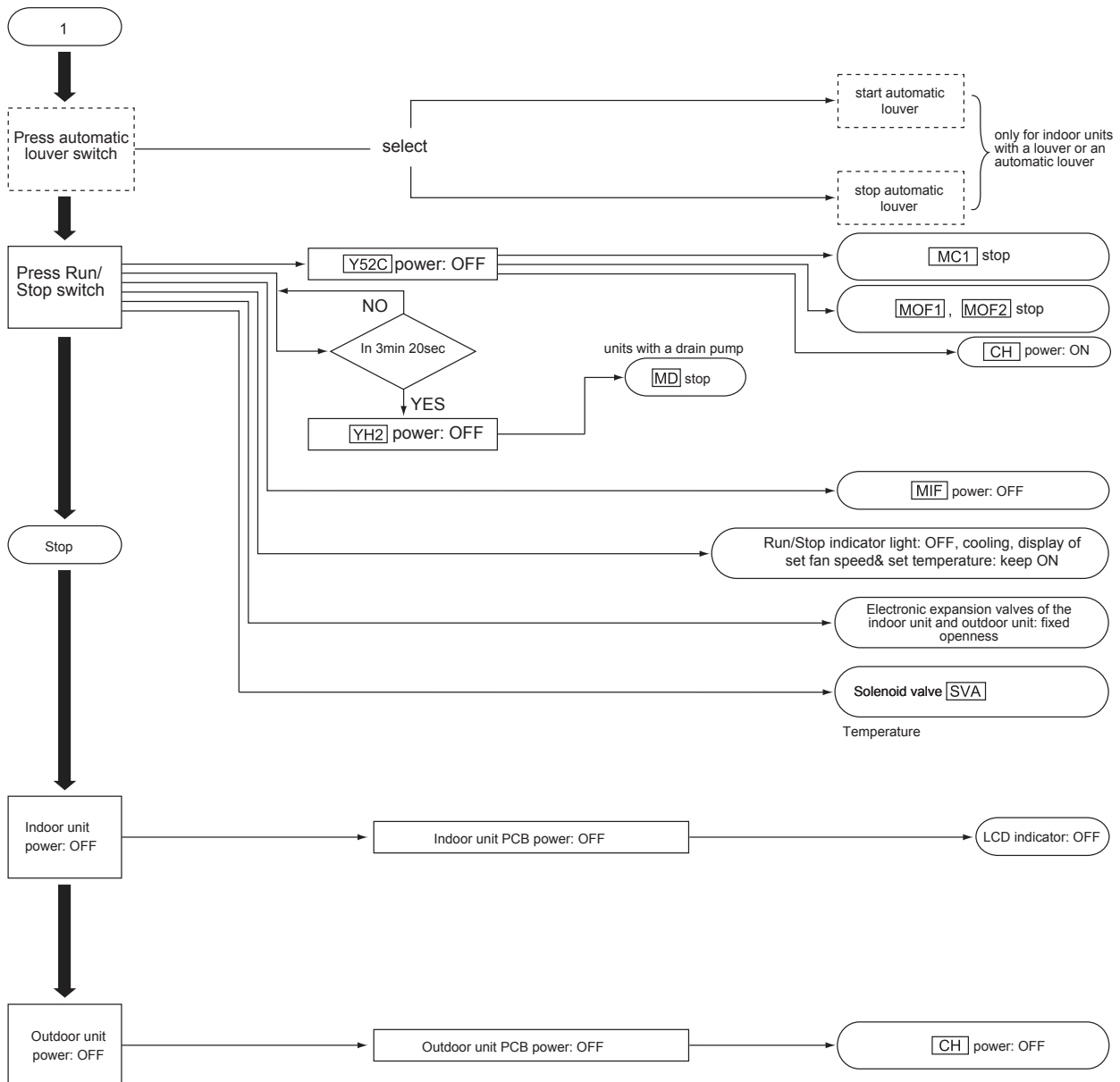

Dry run

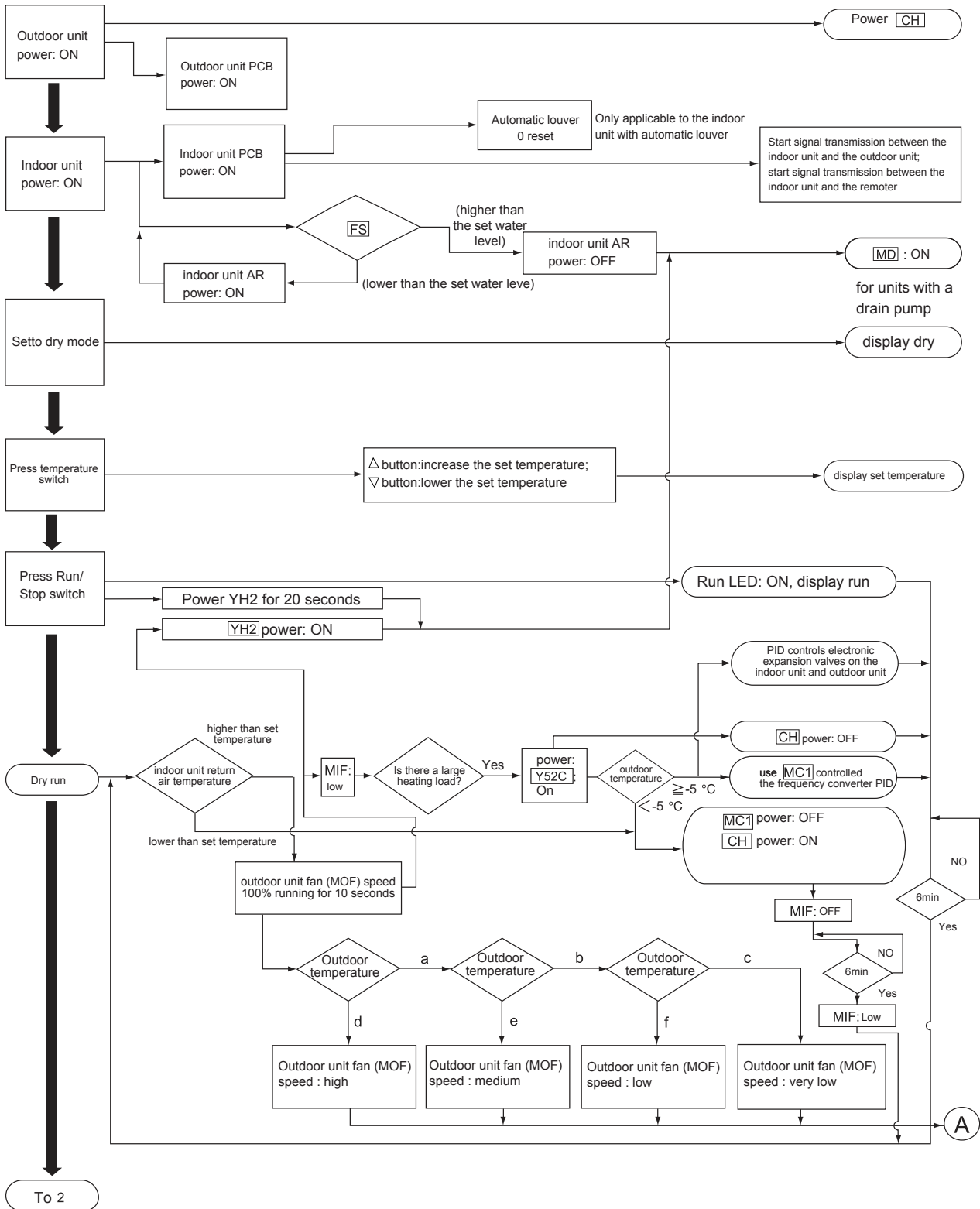

a	b	c	d	e	f
Lower than 25°C	Lower than 18°C	Lower than 11°C	Higher than 25°C	Higher than 18°C	Higher than 11°C

Dry run

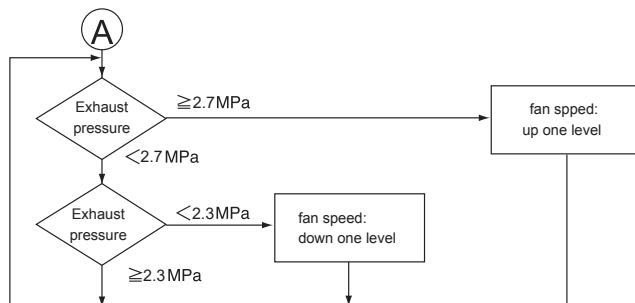
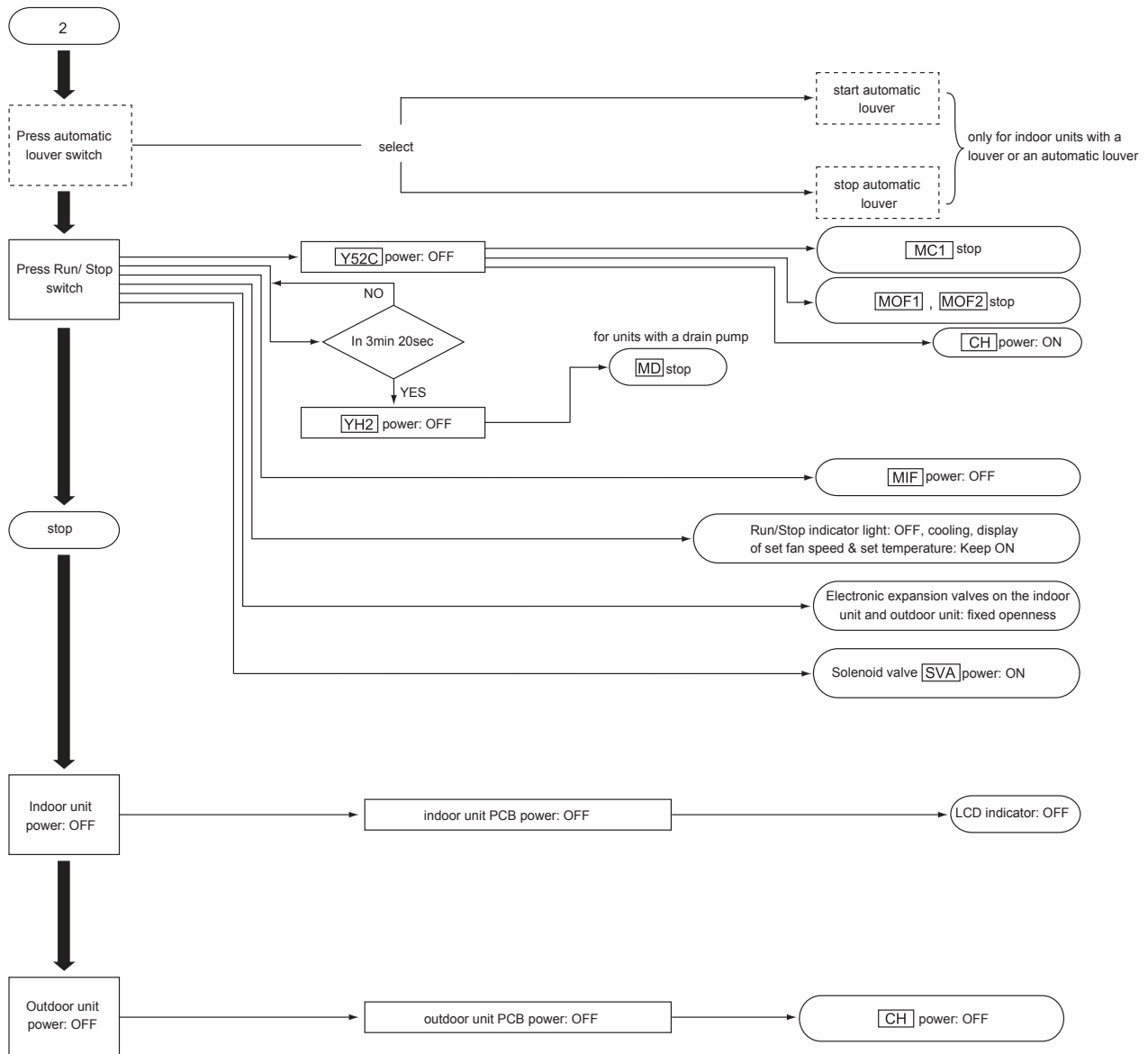

Freeze protection control during the cool or dry run

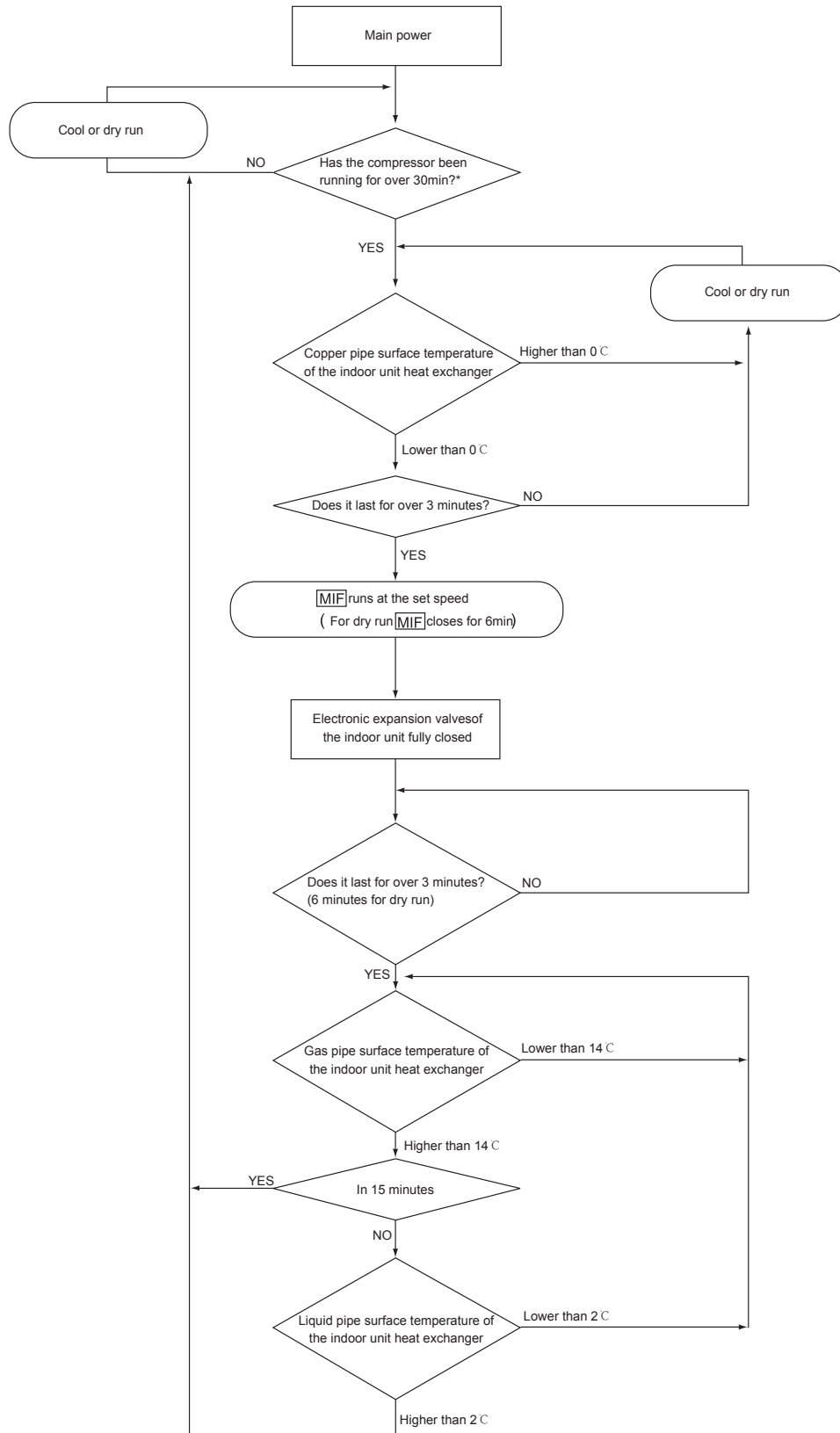

*: The runtime of the compressor is determined by the running condition.

Heating operation

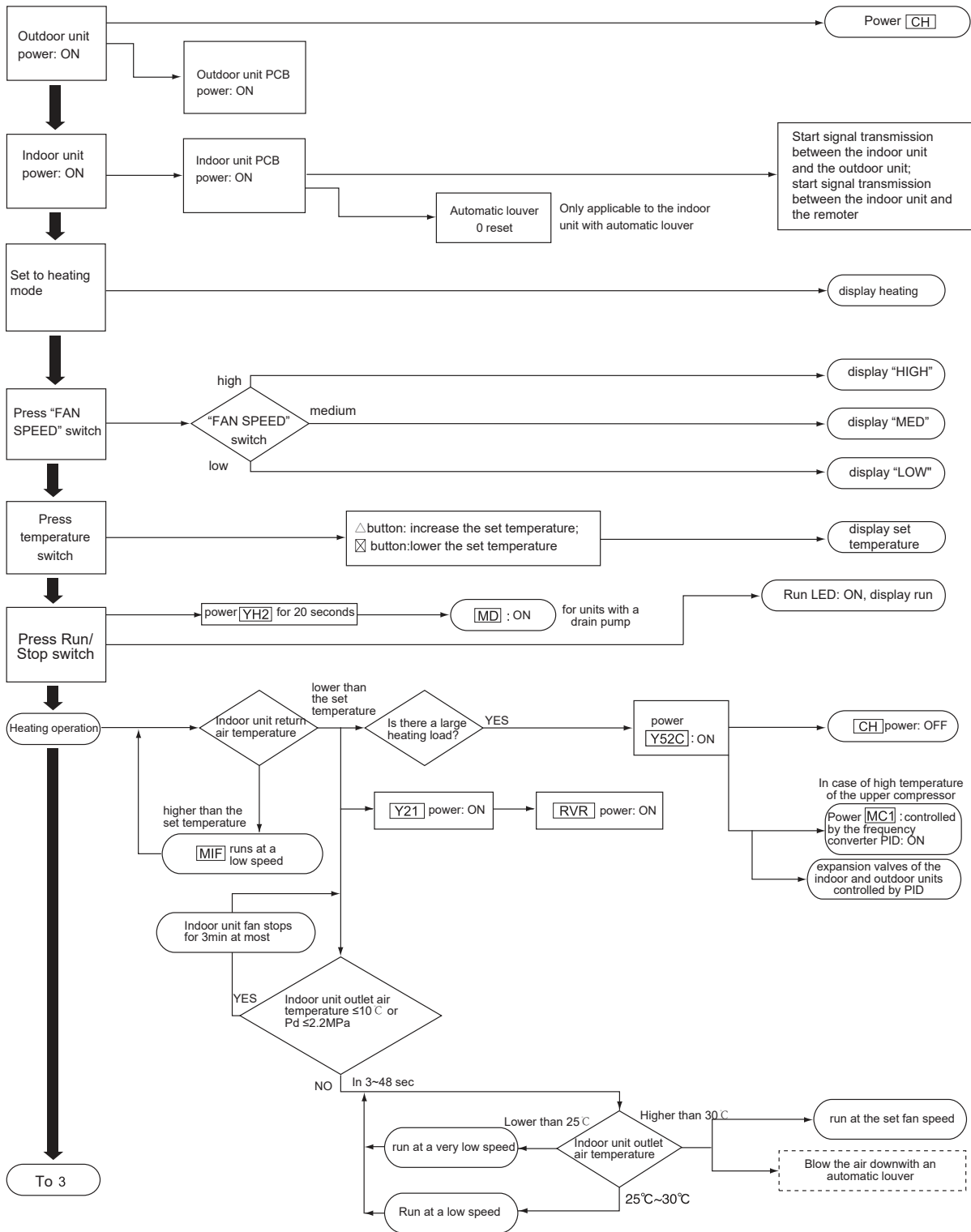

Heating operation

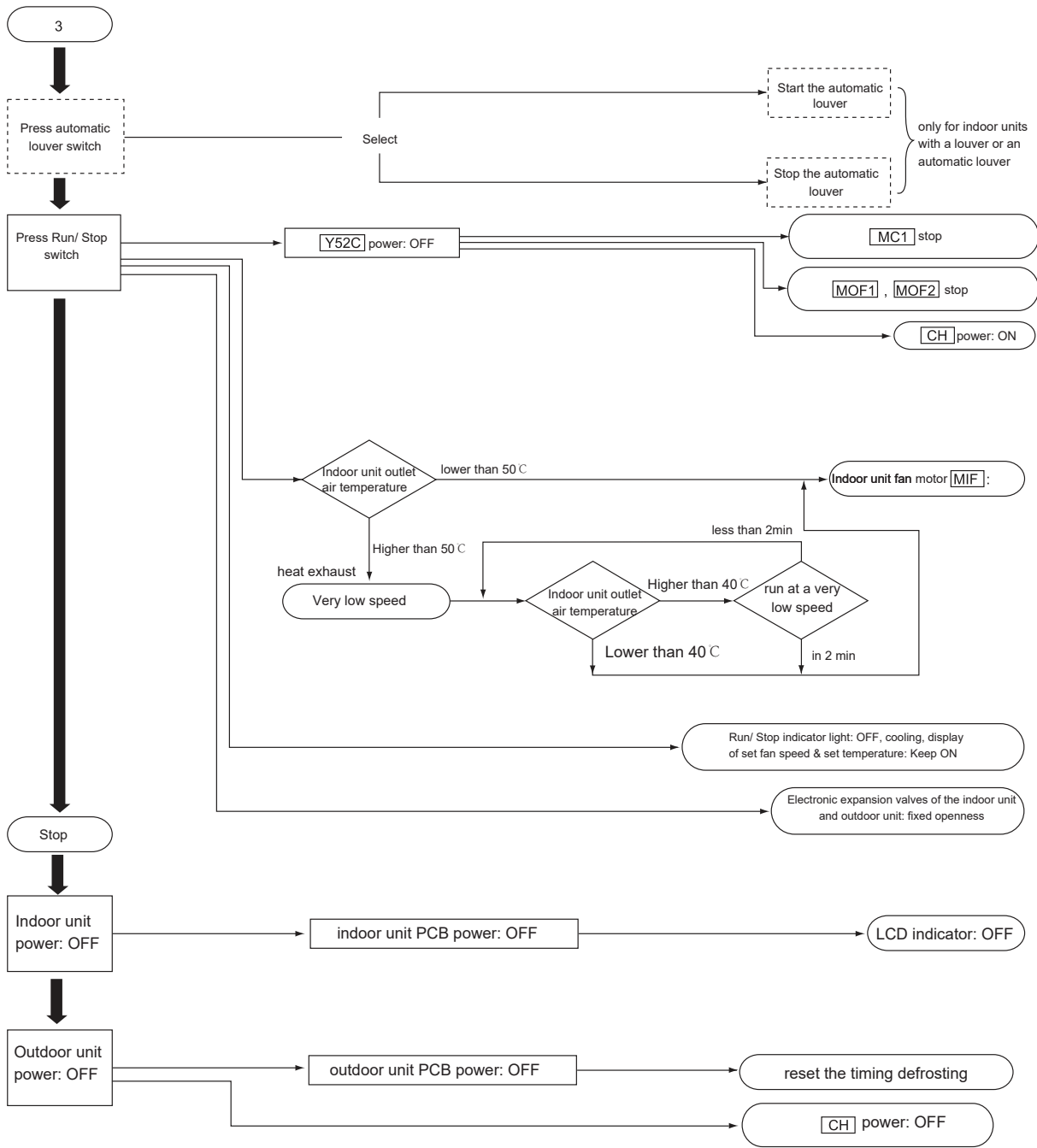

: Not equipped, optional

Defrosting operation

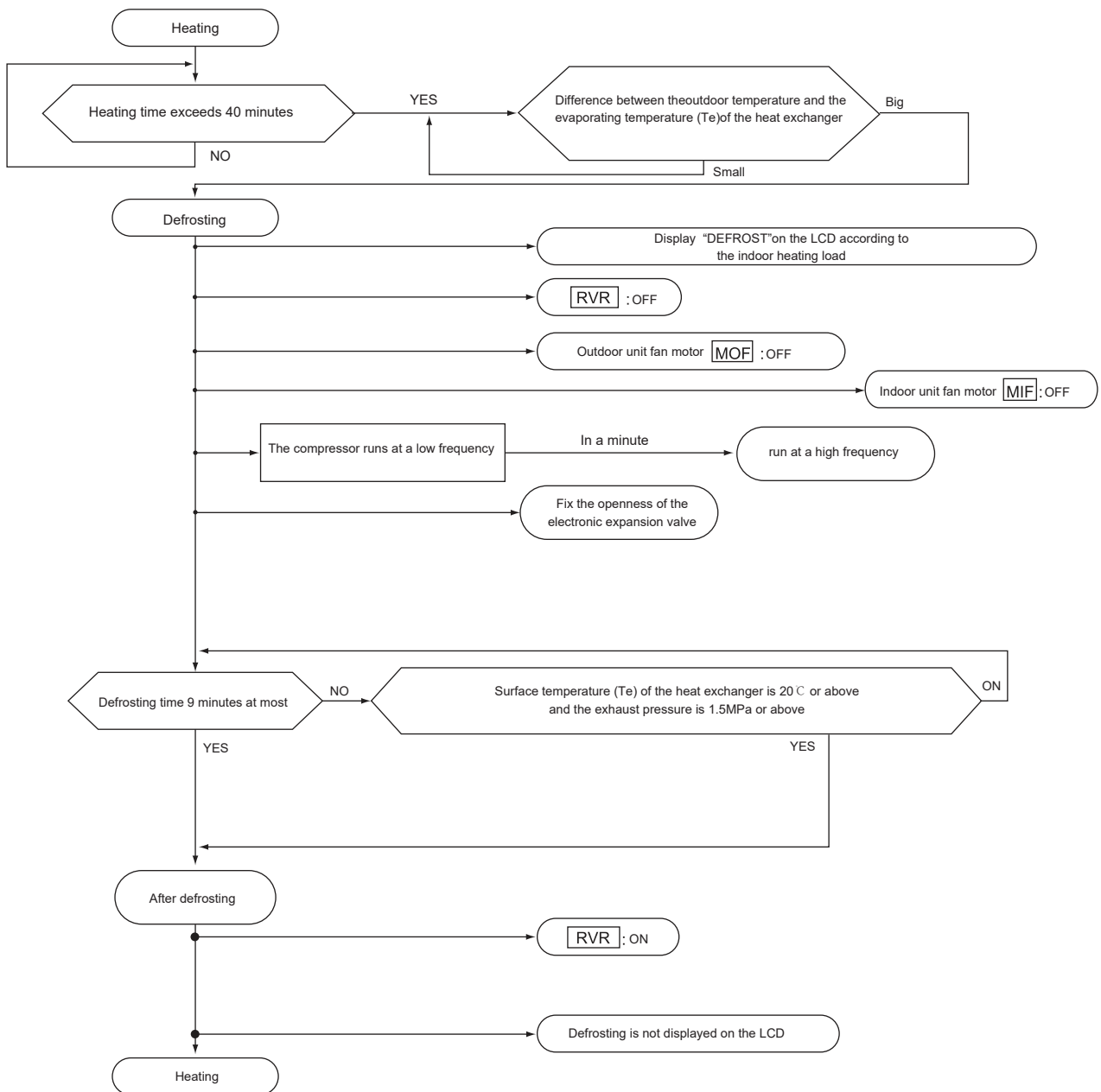

Supply air temperature overheat protection

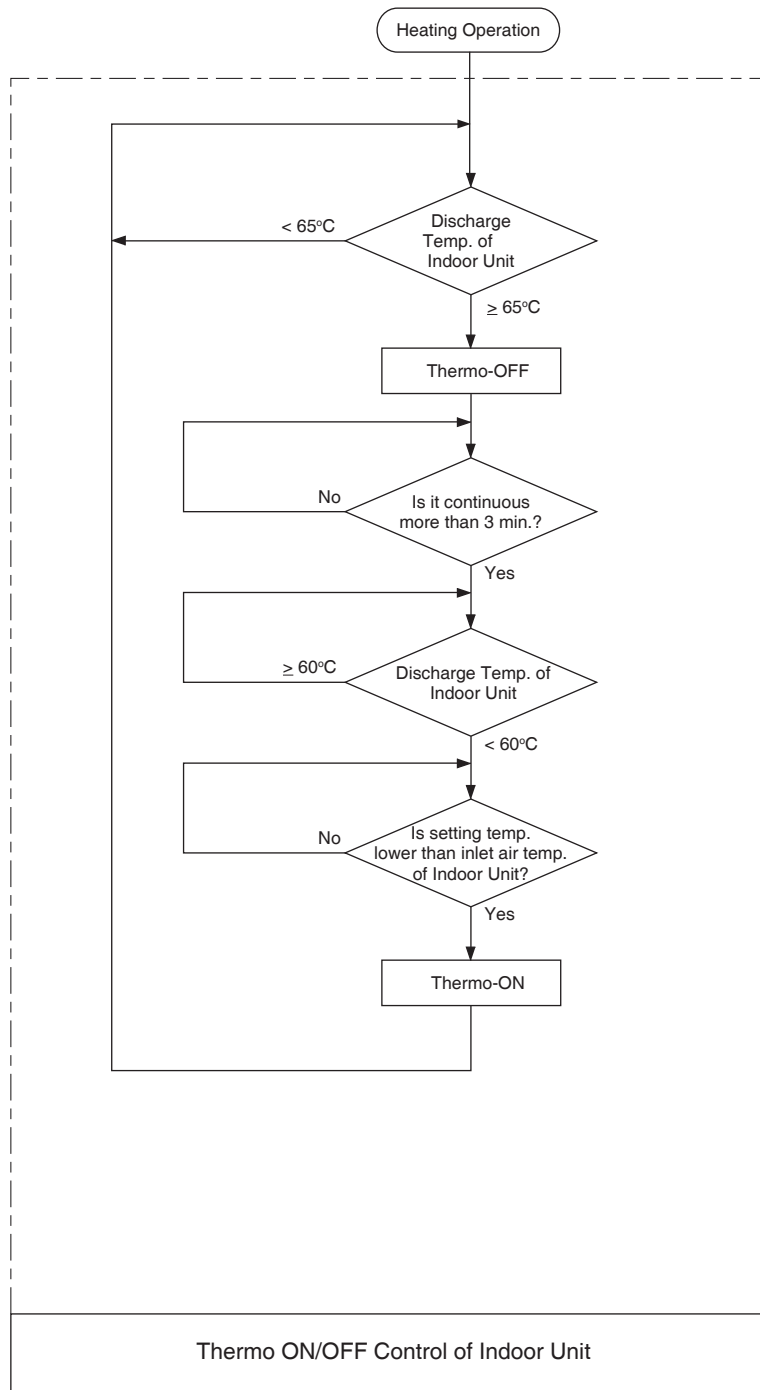

5.4 Electrical wiring diagram

Model: AVWT-76~170HKFXE

ELECTRICAL WIRING DIAGRAM

— : Factory Wiring

- - - : Field Wiring

⚠ Electrical Operation or Periodic Inspection is Allowed Only After the Main Power is Turned Off for Ten Minutes

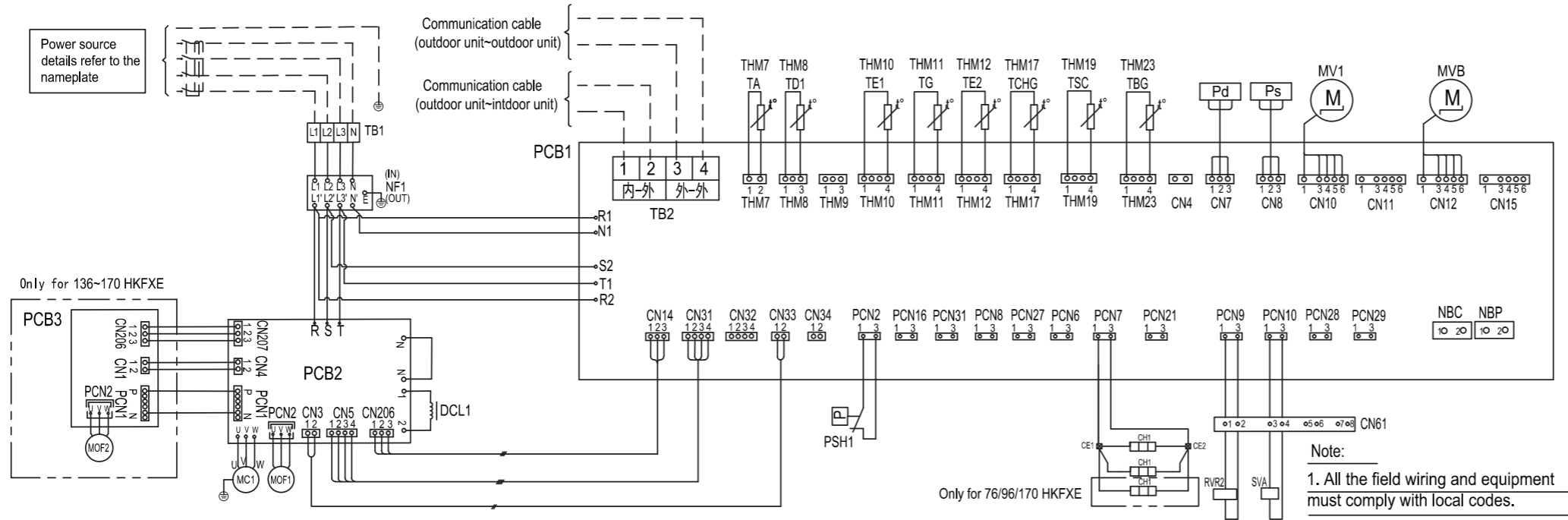

Mark	Name
CH	Crankcase Heater
CN,PCN	Connector
DCL	Reactor
⊕	Protective Earth
MC	Motor for Compressor
MOF	Motor for Outdoor Fan
MV	Micro-Computer Control Expansion Valve
NF	Noise Filter
PCB	Printed Circuit Board
Pd,Ps	Sensor for Refrigerant Pressure
PSH	Pressure Switch for Protection
RVR	Reversing Valve Relay
SVA,S,J1,J2	Solenoid Valve
TB	Terminal Board
THM	Thermistor
○	Terminals

Electrical Control Box of Outdoor Unit
The Electrical Control Box

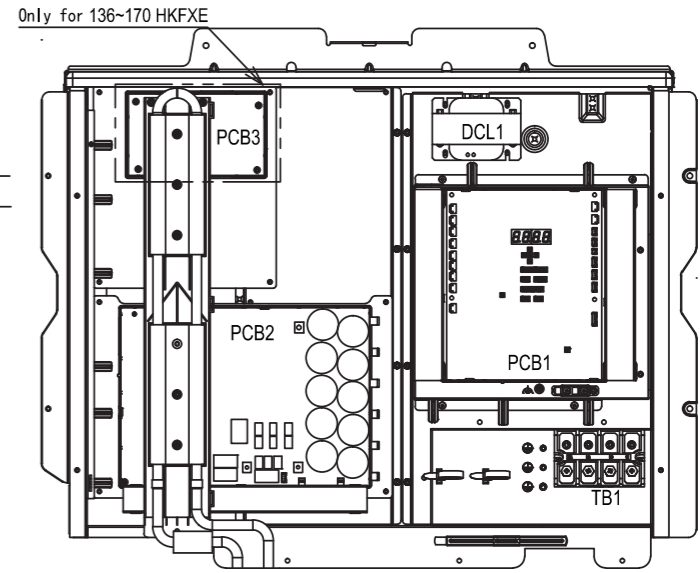

The Electrical Control Box
(After opening the division plate P)

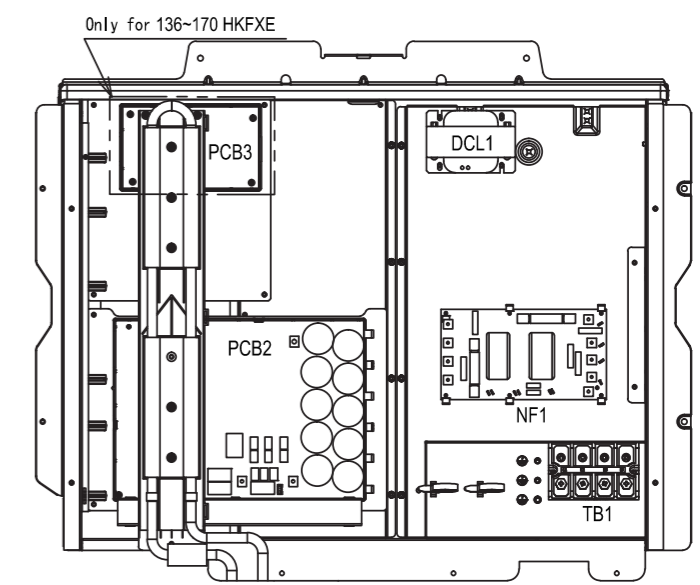

Location of Main Parts
8-12HP

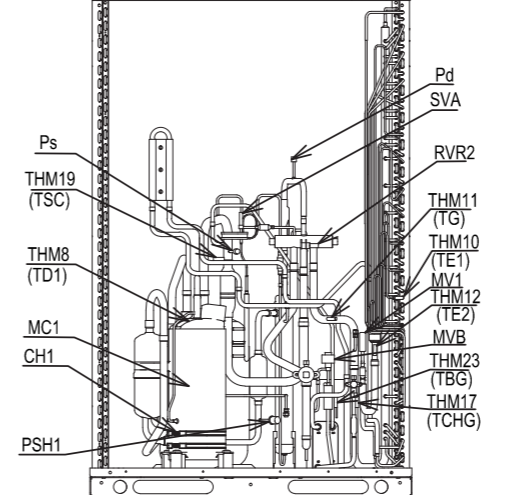

14-18HP

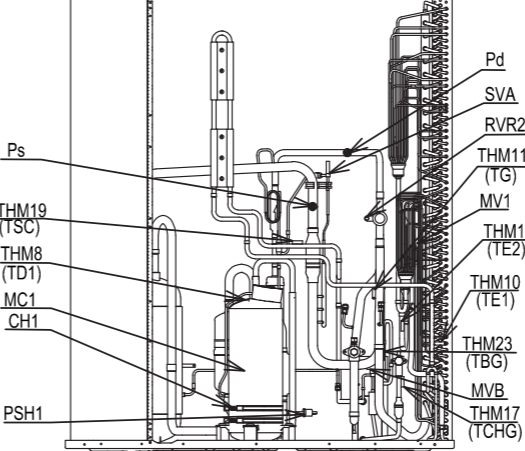

The figure above is only used to illustrate the relative position of main parts.

Calculating Method of Additional Refrigerant Charge(W kg)		Calculating Method										Additional Charge (kg)													
NO.	NAME																								
1	W1	Additional refrigerant charge calculation for liquid piping (W1 kg)										kg													
		Pipe Diameter	Total Piping Length (m)	Additional Charge Per Meter (kg)	Additional Charge (kg)	Pipe Diameter	Total Piping Length (m)	Additional Charge Per Meter (kg)	Additional Charge (kg)																
		Ø28.6	m	×0.600=		Ø25.4	m	×0.480=																	
		Ø22.2	m	×0.370=		Ø19.05	m	×0.260=																	
		Ø15.88	m	×0.170=		Ø12.7	m	×0.110=																	
		Ø9.53	m	×0.056=		Ø6.35	m	×0.024=																	
2	W2	Additional refrigerant charge calculation for indoor unit (W2 kg) :										kg													
		Series	model	05	07	09	12	14	15	17	18		19	22	24	27(28)	30	38	48	54	76(96)	114	154	190	
		Ceiling Ducted Type (AC/DC Low-height)	AVE→*HCFL; AVE→*HJFDL	0.12	0.12	0.21	0.21	0.26	0.26	0.36	0.38		0.38												
		Ceiling Ducted Type (Low/High Static Pressure)	AVD→*HCFL; AVD→*HCFC		0.19	0.19	0.27	0.27		0.42	0.42		0.42	0.60	0.60	0.60	0.80	0.86	1.57						
		Ceiling Ducted Type (DC Dynamic Static Pressure)	AVD→*HJFH		0.19	0.19	0.27	0.27		0.42	0.42			0.60	0.60	0.80	0.86	1.57							
		1-way Cassette Type	AVY→*UXJSJA/KA		0.21	0.21	0.28	0.28		0.38			0.38												
		2-way Cassette Type	AVL→*UXJSGA/HA		0.21	0.21	0.21	0.48		0.48			0.48	0.48	0.48	0.81	0.81	0.81							
		4-Way Cassette Type	AVBC→*HJFKA			0.29	0.29	0.40		0.40	0.59		0.59	0.75	0.75	0.75	0.75	0.75							
		Mini 4-Way Cassette	AVC→*HJFA		0.14	0.14	0.21	0.21		0.31	0.31		0.31												
		Floor Concealed Type	AVH→*UXCSAA/BA			0.19	0.26			0.36			0.36												
		Ceiling&Floor Type	AVV→*URSCA/B/C							0.42	0.42		0.42	0.58	0.58	0.58	0.75								
		Console Type	AVK→*HJFCAA		0.13	0.20	0.20	0.29		0.29	0.29														
		Wall Mounted Type	AVS→*HJFTDD; AVS→*HJFDJD		0.23	0.23	0.23	0.23		0.31	0.41			0.41	0.41										
		All Fresh Air Indoor Unit	AVA→*UXCSCH/QH/RH; AVA→*UX6SRH/SH/TH											0.40	0.91	1.57	1.57	2.59	3.06						
		Note: Maximum W2 for different outdoor unit:																							
		Capacity(kBTU/h) 76-308 326-386 402-544 556-618 634-696 714-816 824-928 946-1088																							
		Max. W2 6kg 8kg 10kg 12kg 14kg 16kg 19kg 21kg																							
3	W3	The Ratio of Indoor Unit Connection Capacity (Indoor Unit Total Capacity/Outdoor Unit Capacity) Additional Charge(W3 Kg)										kg													
		I.U.Capacity Ratio	Refrigerant Amount	I.U.Capacity Ratio	Refrigerant Amount																				
		<100%	0.0	100~150%	0.5																				
4	W	Total Ref. Charge of This System = W1 + W2 + W3																						kg	
		Note: Ensure that the total additional charge should not be exceeded the max. additional refrigerant charge quantity as shown in the table below.																							
		Max. Additional Refrigerant charge Quantity																							
		Capacity(kBTU/h) 76-114 136-154 170-190 212-232 250-272 290-344 366-464 482-618 634-696 714-816 824-928 946-1088																							
		Max. Additional Ref. Charge(kg) 24.0 31.0 34.0 38.0 39.0 50.0 53.0 68.0 73.0 80.0 90.0 100.0																							

ELECTRICAL WIRING DIAGRAM

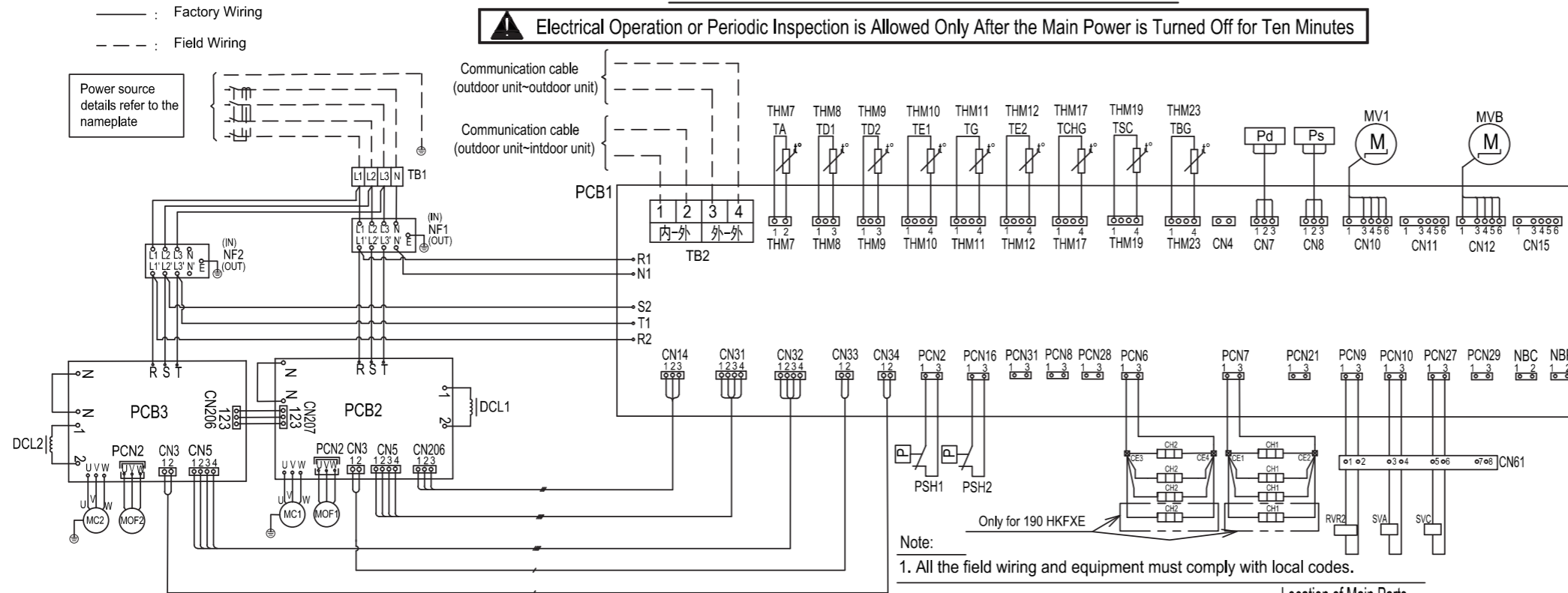

Mark	Name
CH	Crankcase Heater
CN,PCN	Connector
DCL	Reactor
⊕	Protective Earth
MC	Motor for Compressor
MOF	Motor for Outdoor Fan
MV	Micro-Computer Control Expansion Valve
NF	Noise Filter
PCB	Printed Circuit Board
Pd,Ps	Sensor for Refrigerant Pressure
PSH	Pressure Switch for Protection
RVR	Reversing Valve Relay
SVA,S,J1,J2	Solenoid Valve
TB	Terminal Board
THM	Thermistor
○	Terminals

Electrical Control Box of Outdoor Unit
The Electrical Control Box

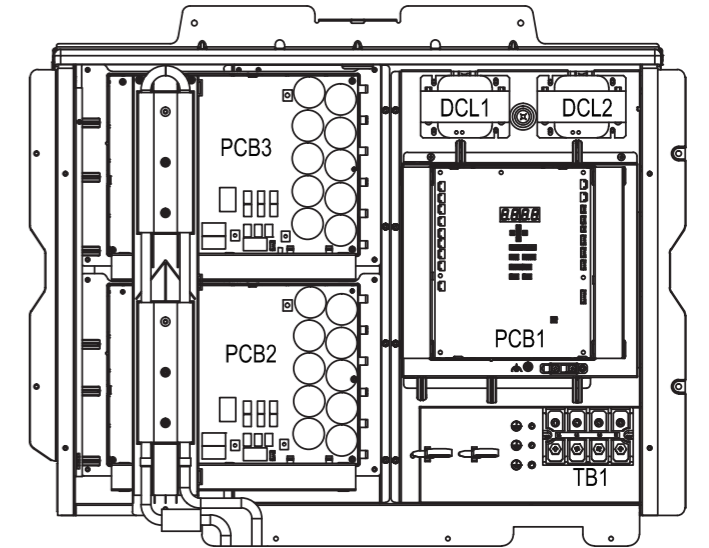

The Electrical Control Box
(After opening the division plate P)

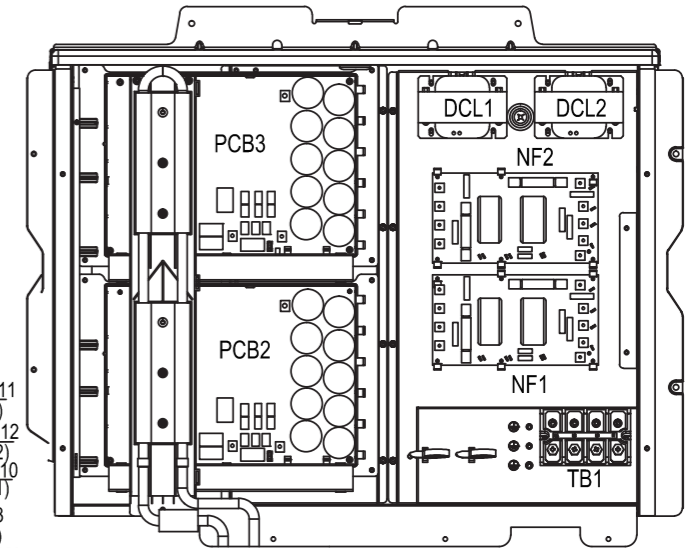

Calculating Method of Additional Refrigerant Charge(W kg)																										
NO.	NAME	Calculating Method						Additional Charge (kg)																		
1	W1	Additional refrigerant charge calculation for liquid piping (W1 kg)						kg																		
		Pipe Diameter	Total Piping Length (m)	Additional Charge Per Meter (kg)	Additional Charge (kg)	Pipe Diameter	Total Piping Length (m)		Additional Charge Per Meter (kg)	Additional Charge (kg)																
		Ø28.6	m	×0.600=		Ø25.4	m		×0.480=																	
		Ø22.2	m	×0.370=		Ø19.05	m		×0.260=																	
		Ø15.88	m	×0.170=		Ø12.7	m		×0.110=																	
		Ø9.53	m	×0.056=		Ø6.35	m	×0.024=																		
2	W2	Additional refrigerant charge calculation for indoor unit (W2 kg) :						kg																		
		Series	model	05	07	09	12		14	15	17	18	19	22	24	27(28)	30	38	48	54	76(96)	114	154	190		
		Ceiling Ducted Type (AC/DC Low-height)	AVE~*HCFRL; AVE~*HJFDL	0.12	0.12	0.21	0.21		0.26	0.26	0.36	0.38	0.38													
		Ceiling Ducted Type (Low/High Static Pressure)	AVD~*HCFCL; AVD~*HCFCH	0.19	0.19	0.27	0.27		0.27	0.27	0.42	0.42	0.42	0.60	0.60	0.60	0.60	0.80	0.86	1.57						
		Ceiling Ducted Type (DC Dynamic Static Pressure)	AVD~*HJFH	0.19	0.19	0.27	0.27		0.27	0.27	0.42	0.42	0.42	0.60	0.60	0.80	0.86	1.57								
		1-way Cassette Type	AVY~*UXJSA/KA	0.21	0.21	0.28	0.28		0.28	0.28	0.38	0.38	0.38													
		2-way Cassette Type	AVL~*UXJGA/HA	0.21	0.21	0.21	0.48		0.48	0.48	0.48	0.48	0.48	0.48	0.81	0.81	0.81									
		4-Way Cassete Type	AVBC~*HJFKA	0.29	0.29	0.29	0.40		0.40	0.40	0.59	0.59	0.59	0.75	0.75	0.75	0.75	0.75	0.75							
		Mini 4-Way Cassette	AVC~*HJFA	0.14	0.14	0.21	0.21		0.21	0.31	0.31	0.31	0.31													
		Floor Concealed Type	AVH~*UXCSAA/BA	0.19	0.19	0.26	0.26		0.26	0.36	0.36	0.36	0.36													
		Ceiling&Floor Type	AVV~*URSCA/B/C	0.19	0.19	0.26	0.26		0.26	0.36	0.36	0.36	0.36	0.42	0.42	0.58	0.58	0.58	0.75							
		Console Type	AVK~*HJFCAA	0.13	0.20	0.20	0.29		0.29	0.29	0.29	0.29	0.29													
		Wall Mounted Type	AVS~*HJFTDD; AVS~*HJFDJD	0.23	0.23	0.23	0.23		0.23	0.31	0.31	0.41	0.41	0.41	0.41											
		All Fresh Air Indoor Unit	AVA~*UXCSCH/QH/RH AVA~*UX6SRH/SH/TH											0.40	0.91	1.57	1.57	2.59	3.06							
Note: Maximum W2 for different outdoor unit:																										
		Capacity(kBTU/h)	76-308	326-386	402-544	556-618	634-696	714-816	824-928	946-1088																
		Max. W2	6kg	8kg	10kg	12kg	14kg	16kg	19kg	21kg																
3	W3	The Ratio of Indoor Unit Connection Capacity (Indoor Unit Total Capacity/Outdoor Unit Capacity) Additional Charge(W3 Kg)						kg																		
		I.U.Capacity Ratio	Refrigerant Amount	I.U.Capacity Ratio	Refrigerant Amount																					
		<100%	0.0	100~150%	0.5																					
4	W	Total Ref. Charge of This System = W1 + W2 + W3						kg																		
Note: Ensure that the total additional charge should not be exceeded the max. additional refrigerant charge quantity as shown in the table below.																										
Max. Additional Refrigerant Charge Quantity																										
		Capacity(kBTU/h)	76-114	136-154	170-190	212-232	250-272	290-344	366-464	482-618	634-696	714-816	824-928	946-1088												
		Max. Additional Ref. Charge(kg)	24.0	31.0	34.0	38.0	39.0	50.0	53.0	68.0	73.0	80.0	90.0	100.0												

Location of Main Parts
20-24HP

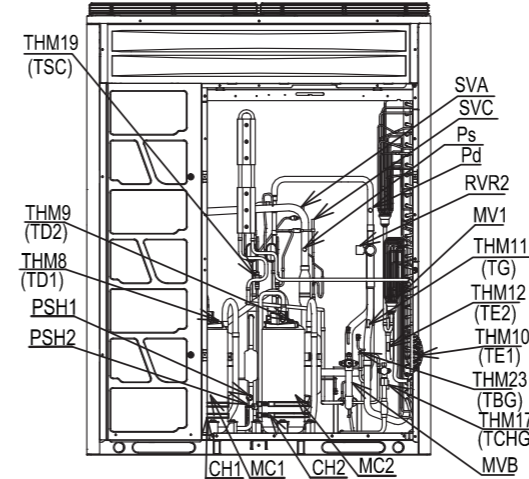

26-28HP

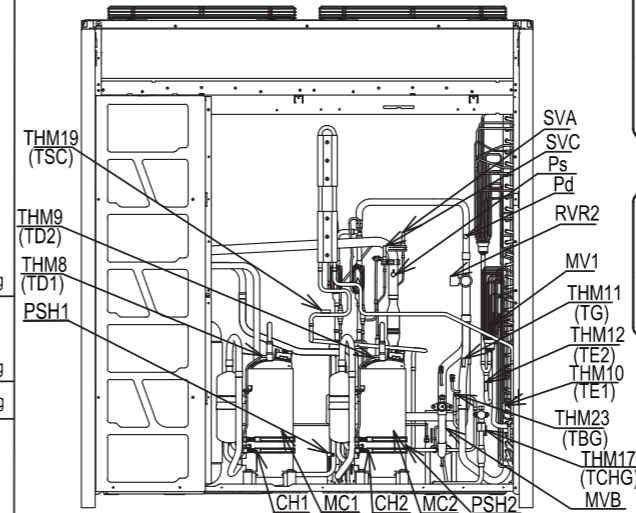

The figure above is only used to illustrate the relative position of main parts.

INSTALLATION



1. Before Installation

1.1 Outdoor Unit & Refrigerant Cycle

Regarding structure drawings and refrigerant cycle diagram, please refer to Design chapter.

1.2 Necessary Tools and Instrument List for Installation

The design pressure for this product is 4.15MPa.

To avoid accidental mixing of the different refrigerant or different refrigerant oil, the sizes of the charging connections have been changed. It is necessary to prepare the following tools before installation.

No.	Tool	No.	Tool	No.	Tool	No.	Tool
1	Handsaw	6	Copper Pipe Bender	11	Spanner	16	Leveller
2	Phillips Screwdriver	7	Plier	12	Charging Cylinder	17	Clamper for Solderless Terminals
3	Vacuum Pump	8	Pipe Cutter	13	Control Valve	18	Hoist (for Indoor Unit)
4	Refrigerant Gas Hose	9	Brazing Kit	14	Cutter for Wires	19	Ammeter
5	Megohmmeter	10	Hexagon Wrench	15	Gas Leak Detector	20	Voltage Meter

Note:

Use tools and measuring instruments are for the new refrigerant R410A only in case of direct contact with the refrigerant.

DANGER

The pressure of refrigerant R410A is 1.4 times higher than that of conventional refrigerant, impurities such as moisture, oxide film, and grease affect easily R410A. Be sure to remove any moisture, dust, different refrigerant or refrigerant oil from the refrigerant cycle. If materials other than specified are used, it may lead to explosion, injury, leakage, electric shock or a fire.

Before Installation

○: Interchangeable with current R22

■: Only for Refrigerant R410A (Not interchangeable with R22)

×: Prohibited

●: Only for Refrigerant R407C (Not interchangeable with R22)

Measuring Instrument and Tool		Interchangeability with R22		Reason of Non-Interchangeability and Attention (★: Strictly Required)	Application
		R407C	R410A		
Refrigerant Pipe	Pipe Cutter Chamfering Reamer	○	○	—	Cutting pipe; Removing burrs
	Flaring Tool	○	○■	* R410A requires high pressure resistance piping and larger flaring. In case of material 1/2H, flaring is not applicable. (The flaring tools for R410A are applicable to R407C)	Flaring for tubes
	Extrusion - Adjustment Gauge		■		Dimensional control for expanded portion of tube after flaring"
	Pipe Bender	○	○	* In case of material 1/2H, bending is not applicable. Use elbow for bend and braze.	Bending
	Expanding Tool	○	○	* In case of material 1/2H, expanding of tube is not applicable. Use socket for connecting tube.	Expanding tubes
	Torque Wrench	○	■	* For Φ12.7, Φ15.88 of R410A, wrench size is up to 2mm	Connection of flare nut
			○	* For Φ6.35、Φ9.53、Φ19.05, wrench size is the same.	
	Brazing Tool	○	○	* Perform brazing work properly (adjustable flame, feeding filler)	Brazing for tubes
	Nitrogen Gas	○	○	* Strictly control against contamination (nitrogen purging during brazing.)	"Prevention from oxidation during brazing Air-tightness test"
Lubrication Oil (for Flare Surface)	●	■	* Use synthetic oil which is equivalent to the oil used in the refrigeration cycle. * Synthetic oil absorbs moisture quickly.	Applying oil to the flared surface	
Refrigerant Charge and Vacuum Drying	Refrigerant Cylinder	●	■	* Check the cylinder for the corresponding refrigerant. ★ Liquid refrigerant charging is required regarding zeotropic refrigerant."	Refrigerant charging
	Vacuum Pump	○	○	★ The current ones are applicable. However, it is required to mount a vacuum pump adapter which can prevent reverse flow when a vacuum pump stops, resulting in no reverse oil flow.	Vacuum pumping
	Adapter for Vacuum Pump Reverse Flow prevention	●	※■		
	Control Valve	●	■	* Not interchangeable due to higher pressures when compared with R22. Connection diameter is different: R410A: UNF1/2, R407C: UNF7/16	Vacuum pumping, vacuum holding, refrigerant charging and check of pressures
	Charging Hose	●	■	★ Do not apply used ones to the different refrigerant. Or mineral oil will flow into the cycle and leads to sludges, resulting in clogging or compressor failure."	
	Charging Cylinder		×	* Use the weight scale	Refrigerant charging
	Weight Scale	○	○	—	Weight measuring instrument
Refrigerant Gas Leakage Detector	●	※■	*The current gas leakage detector (R22) is not applicable due to different detecting method.	Refrigerant charging; Gas leakage check	

※ Interchangeable with R407C.

2. Transportation and Handling

2.1 Transportation

Transport the product as close to the installation location as practical before unpacking. When using a crane, hang the unit according to the description on the label attached to the outdoor unit.

! DANGER

Do not hang the unit by applying the ropes through the wooden pallet.

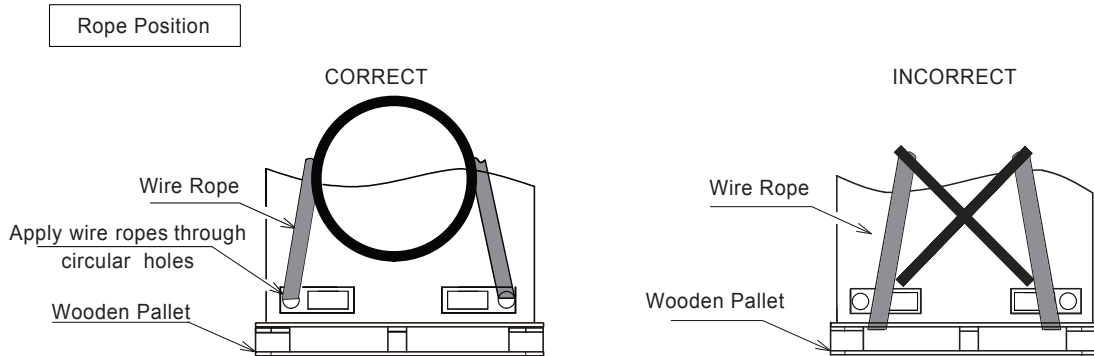

! CAUTION

1. Transportation and Storage

Due to the limited strength of corrugated paper frame, please pay attention to the followings in order to prevent the unit from deformation.

- Do not step on or put any objects on the product.
- Apply two lifting wires onto the outdoor unit when lifting by crane.
- Do not stack the products when storing.

2. Transportation and Wire Rope

- To protect the unit, do not remove any packing.
- Do not stack or put any objects on the product.
- Apply wire ropes on both sides of the unit as shown in the figure.

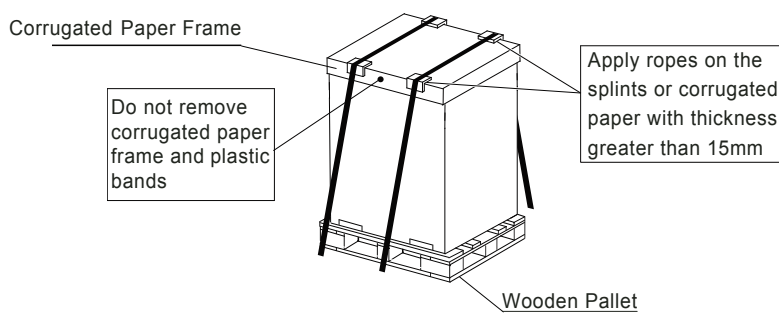

2.2 Hanging Method

When hanging the unit, ensure a balance of the unit, ensure security before lifting smoothly.

- (1) Do not remove any packing materials.
- (2) Hang the unit with packing by two wire ropes as shown in Fig. 2.1.

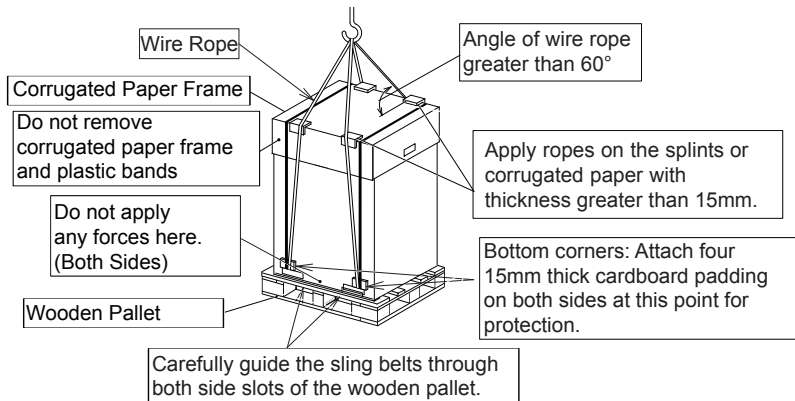

Fig. 2.1 Hanging for Transportation

- (3) Hang the unit without wooden pallet as shown in Fig.2.2.

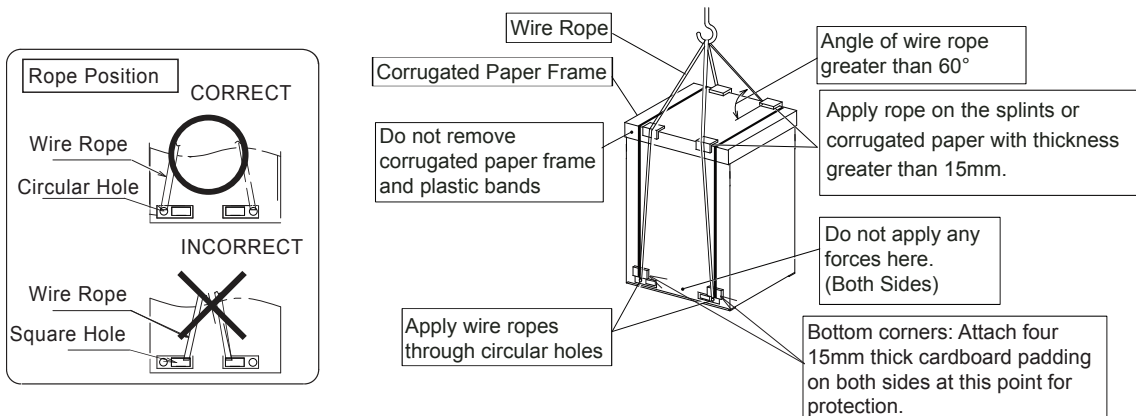
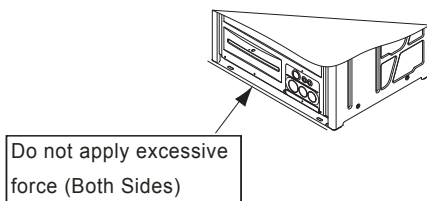

Fig. 2.2 Hanging without Wooden Pallet



Do not apply excessive force to the square holes with forks or other objects. The bottom of the unit may be deformed.

- * Do not push the bottom base by fork.
- * Do not use roller.

NOTE

In case of transportation without packing, protect the unit with splints or cloth.

! WARNING

Do not put any foreign matters into the outdoor unit and check to ensure that no foreign matters left in the outdoor unit before installation and test run. Otherwise, a fire, failure or personal injury and the like may occur.

3. Outdoor Unit Installation

3.1 Service Space

Make the service space when outdoor unit is installed as follows.

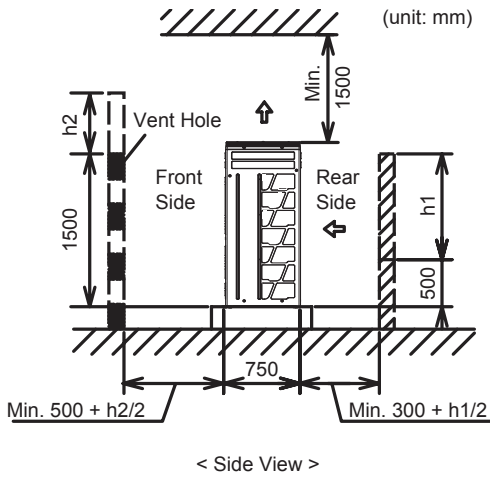

- * In case of no walls in front of and at the rear of the unit, the space of 500mm to the front side and 300mm to the rear side is required.
- * When the wall of front side is higher than 1,500mm, the space of $(500 + h2/2)$ mm to the front side is required.
- * When the wall of rear side is higher than 500mm, the space of $(300 + h1/2)$ mm to the rear side is required.
- * When building a wall in front of the unit, make a vent hole in the wall.
- * When the space to the obstacle above the unit is less than 1,500mm or the space above the unit is closed, set up the duct at the air outlet side in order to prevent short circuit.
- * When there are obstacles above the unit, the four (front, rear, right and left) sides of the unit shall be open in principle.

1. Walls in 2 Directions

In case that the units are installed adjacent to tall buildings and there are no walls in 2 directions, the minimum rear side space is 300mm.

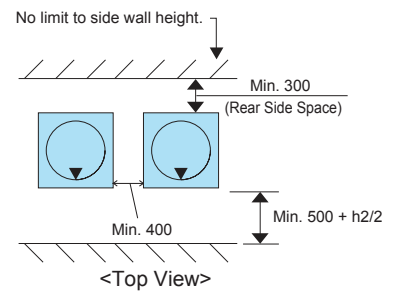
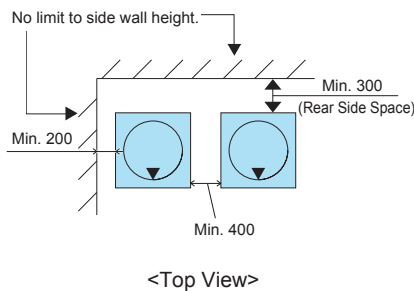
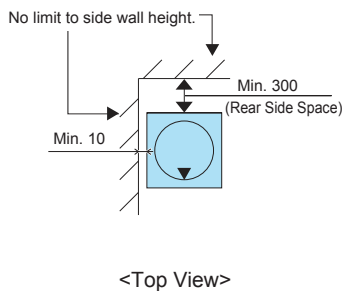

2. Walls in 3 Directions

• Single Installation

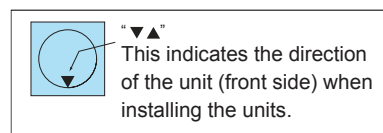
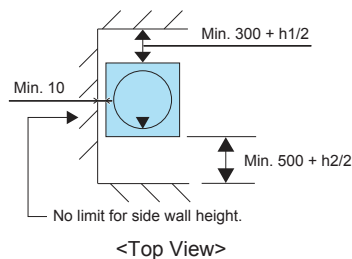

• Multiple / Serial Installation

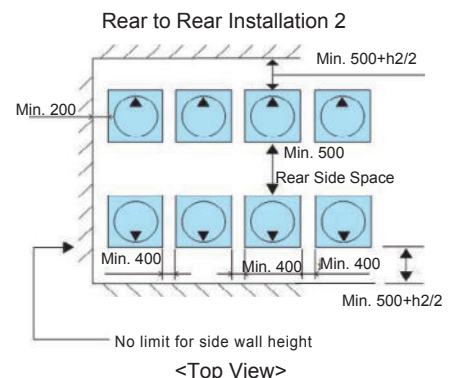
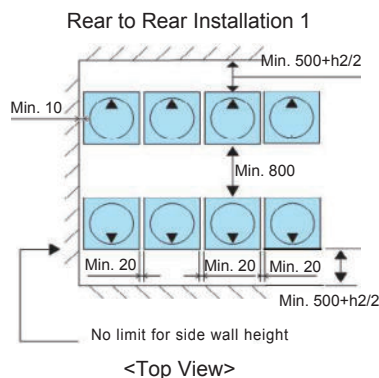
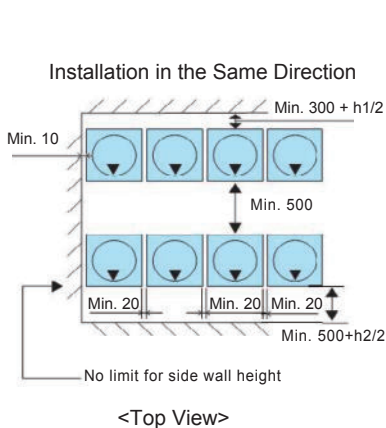

3. Walls in 4 Directions

• Single Installation

unit: mm

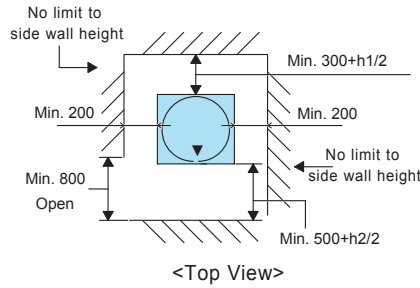

• Multiple / Serial Installation

unit: mm

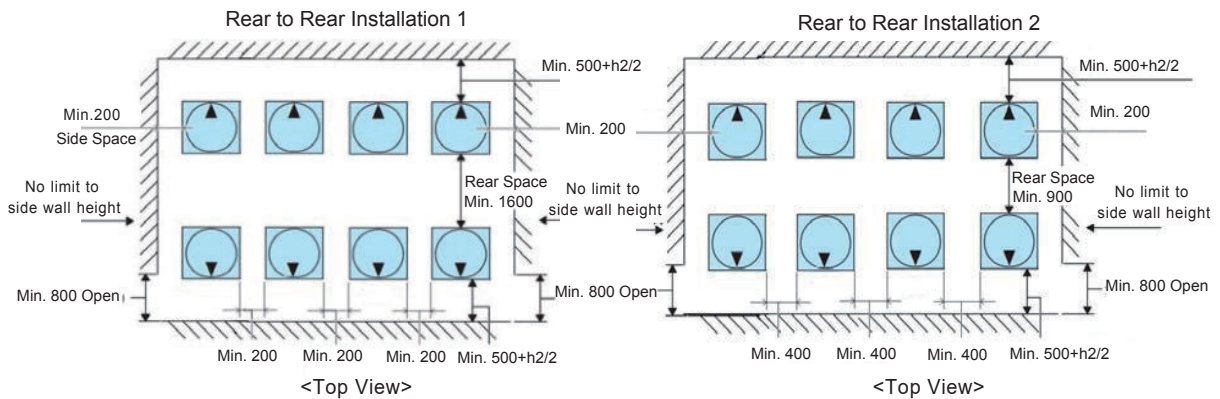
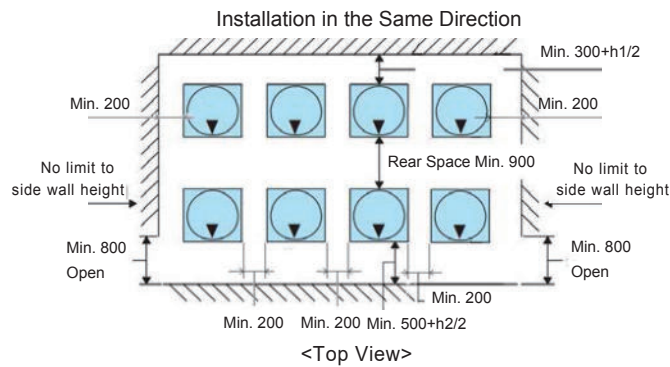

NOTES:

1. Keep the upper side open to prevent mutual interference of inlet and outlet air of each outdoor unit.
2. The dimensions in figure are sufficient spaces around outdoor units for operation and maintenance at typical installing conditions as follows.

[Operation Mode: Cooling Operation, Outside Temp.: 35°C]

In case that the outdoor unit ambient temperature is higher and also the short circuit is likely to occur compared to the installation condition, find an appropriate dimension by calculating air flow current.

3. For the multiple installation, 1 group allows 6 outdoor units (max.).
The space of 1m between each group is required.

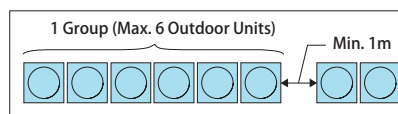





























4. Partly open a wall if the unit is surrounded by walls in four directions.

3.2 Factory-Supplied Accessories

Check to ensure that the following accessories are packed with the outdoor unit.

Table 3.1 Factory-Supplied Accessories

Accessory	76	96	114	136	154	170	190~232	250~272
Accessory Piping	 x1	—	 x2	—	 x1	 x2	—	 x2
Screw (Spare)	 x3	 x3	 x3	 x3	 x3	 x3	 x3	 x3
Electrical accessory pouch	 x1	 x1	 x1	 x1	 x1	 x1	 x1	 x1
Manual	 x1	 x1	 x1	 x1	 x1	 x1	 x1	 x1

NOTE:

If any of these accessories are not packed with the unit, please contact your contractor.

3.3 Installation Conditions

- (1) Install the outdoor unit in a dry and well ventilated environment.
- (2) Install the outdoor unit where it is in the shade or a place where not be exposed to direct sunshine or direct radiation from high temperature heat source.
- (3) Install the outdoor unit where the sound or the discharged air from the outdoor unit does not affect neighbors or surrounding ventilation. The operating sound of the rear or right/left side is 3 to 6 dB(A) higher than the value of the front side specified in this handbook.
- (4) Install the outdoor unit in a space with limited access to general public.
- (5) Check to ensure that the foundation is flat, level and sufficiently strong.
- (6) Do not install the outdoor unit where dust or other contamination could block the outdoor heat exchanger.
- (7) When installing the outdoor unit in snow-covered areas, mount the field-supplied hoods on the top of the outdoor unit and the inlet side of the heat exchanger.
- (8) While operating in rainy days, water has to be discharged. Provide adequate drainage around the foundation. If installing the unit on a roof or a veranda, avoid draining in or over walkways to prevent water dripping on people. In case of installing such a place, provide the additional drainage around the foundation.
- (9) Do not install the outdoor unit in a space where a seasonal wind directly blows to the outdoor heat exchanger or a wind from a building space directly blows to the outdoor fan.

NOTES:

1. Do not install the outdoor unit where there is a high concentration of oil mist, flammable gases, salty air or harmful gases, such as sulphur, and an acid or alkaline environment.
2. Do not install the outdoor unit where the electromagnetic wave directly radiates to the electrical control box.
3. Install the outdoor unit as far from the electromagnetic wave radiator as possible, at least a 3-meter-distance should be ensured.

3.4 Foundation

- (1) The height of the foundation should be 150mm higher than the ground level.
- (2) Install a drainage around foundation for proper drainage.

unit: mm

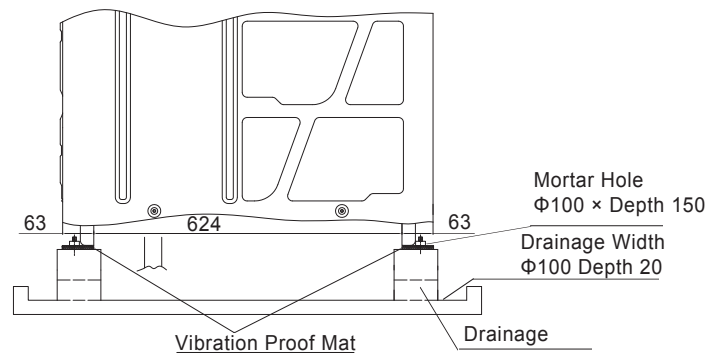

* Provide a concrete foundation as shown in the figure.

* Do not provide a concrete foundation as shown below. Otherwise, the foot of the outdoor unit may be deformed.

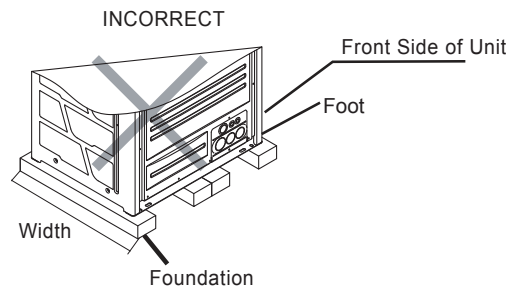
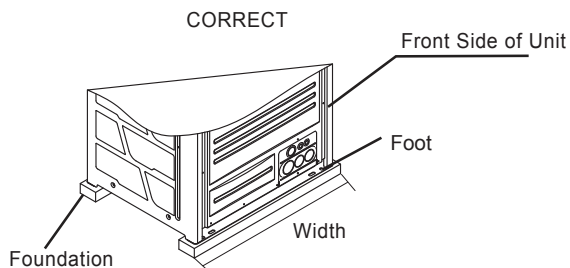

- (3) Install the outdoor unit in the front-rear and right-left direction horizontally. (Use a level gauge.)
Check to ensure that the gradient in four directions (front, rear, right and left) is within 10mm.

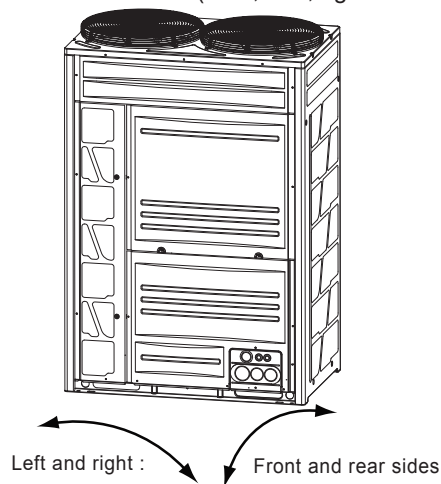

- (4) Provide a strong and proper foundation so that:
 - (a) the outdoor unit is not on an incline.
 - (b) no abnormal sound will be given off.
 - (c) the outdoor unit will not fall down due to a strong wind or earthquake.

(5) When installing the outdoor unit, fix the unit by anchor bolts (field-supplied).

unit: mm

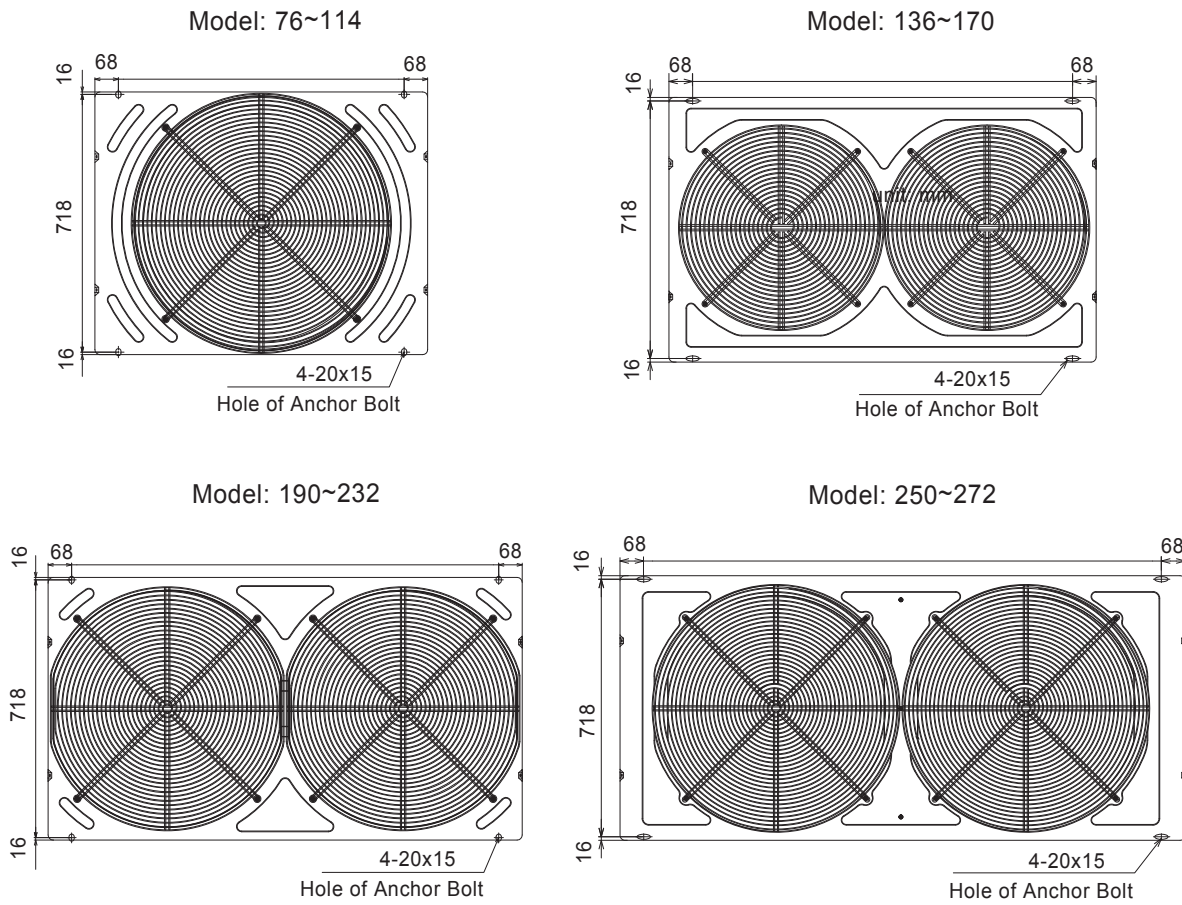

<Position of Anchor Bolts>

Secure the outdoor unit with the anchor bolts.

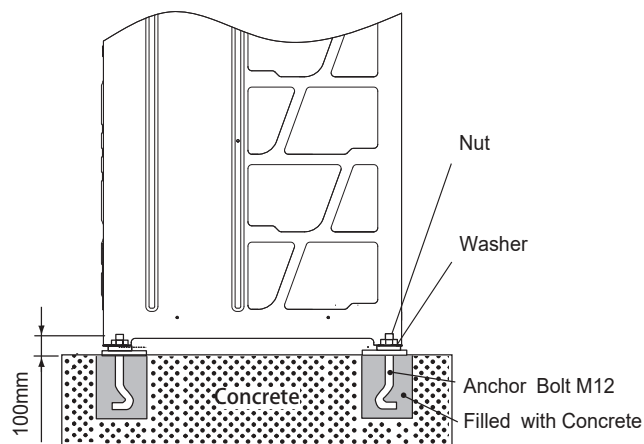

3.5 Drainage

Drainage is discharged during operation, and so do rainwater. Pay attention to the following items:

- (1) Choose a place where a proper drainage is available, or provide a drain ditch.
- (2) Do not install the unit over the walkways. Condensation water may fall on people.
In case of installing the unit in such a place, provide the additional drain pan.
- (3) When drain piping is necessary for the outdoor unit, use the drain boss set (Optional, DC-01Q).
Do not use drain boss and drain pan kit in cold areas. The drain water in drain pipe may be frozen and crack the drain pipe.
- (4) When installing the unit on a roof or a veranda, drain water sometimes turns to ice on a cold morning.
Therefore, avoid draining into an area where people often use because it is slippery.

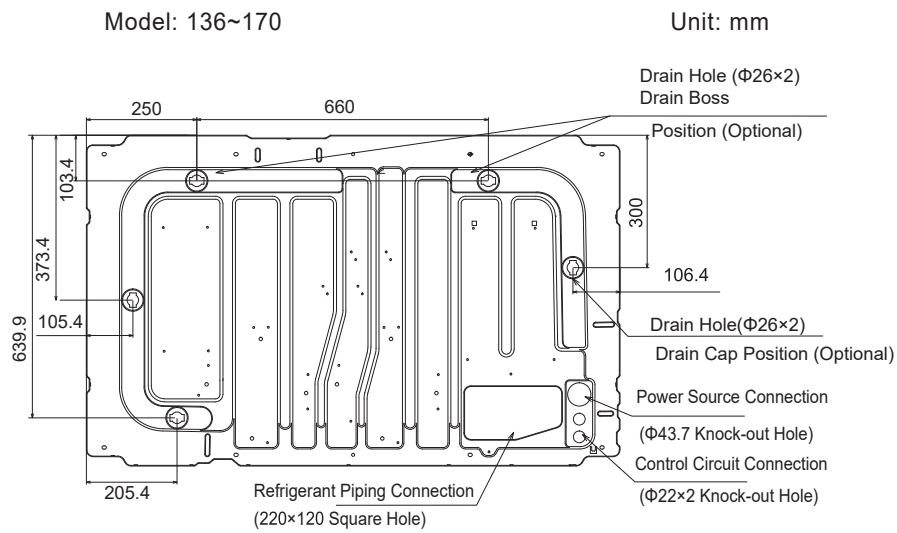
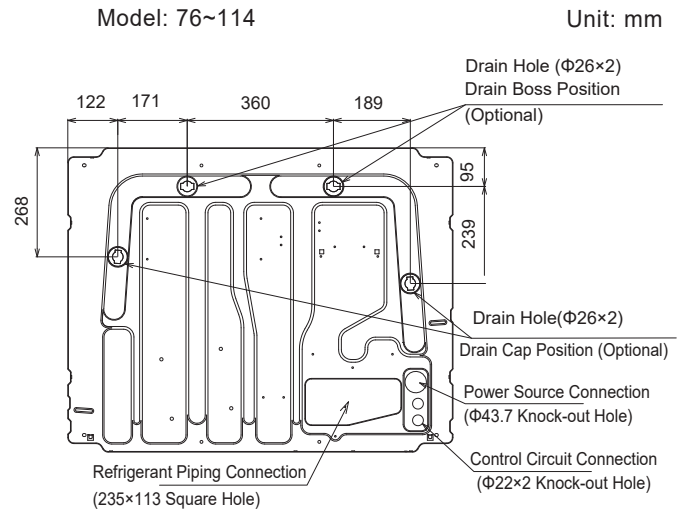

Model: 190~232

Unit: mm

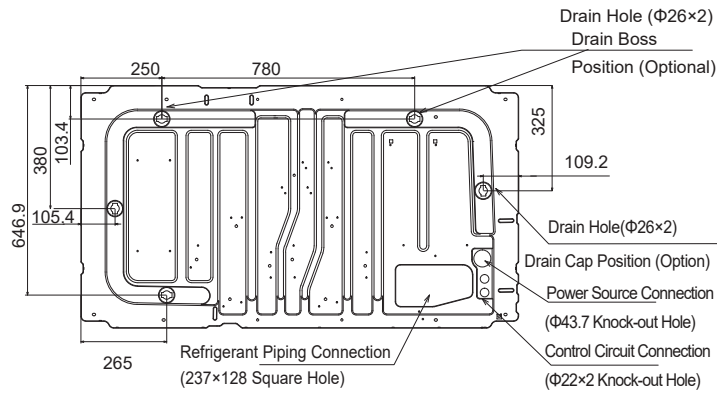

Model: 250~272

Unit: mm

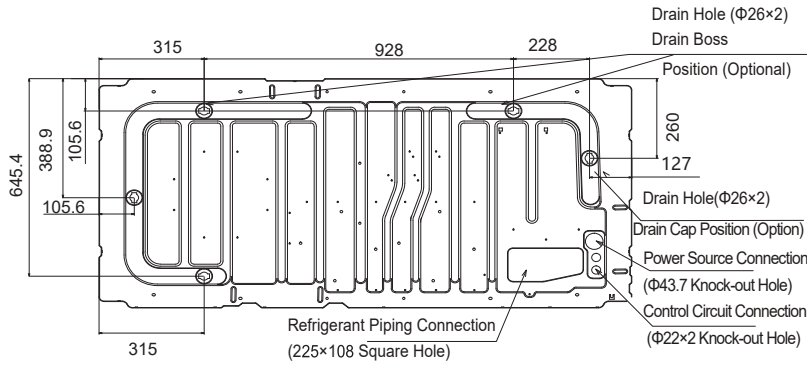

- Drain Boss (Optional Parts)
The drain boss is for the drain pipe connection in order to use outdoor unit bottom base as a drain pan.

Name	Model
Drain Boss	DC-01Q

Component of Drain Boss

Model	Parts Name	Q'ty	Application
DC-01Q	Drain Boss	1	Connection for Drain Piping
	Drain Cap	1	Embolization for Drain Hole
	Rubber Cap	4	Sealing for Boss and Cap

Installation Position

Example: Model 76~114

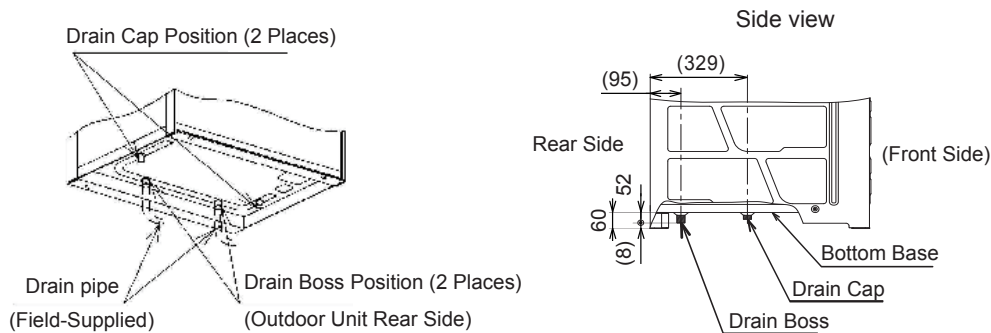

4. Refrigerant Piping Work

! DANGER

- Charge refrigerant R410A in the refrigerant cycle.
Do not charge oxygen, acetylene or other flammable and poisonous gases into the refrigerant cycle when performing a leak test or an air-tightness test. These types of gases are extremely dangerous and could lead to an explosion. It is recommended that compressed air, nitrogen be used for these tests.
- Check to ensure that no pressure exists inside the stop valve before removing the flange.

! CAUTION

Ensure to connect the piping among the units in the same refrigerant cycle.

4.1 Piping Materials

- (1) Prepare field supplied copper pipes.
 - (2) Select piping size from this handbook.
 - (3) Select clean copper pipes. Make sure there is no dust and moisture inside of the pipes. Purge pipes with nitrogen or dry air to remove any dust or foreign matters before connecting pipes. Do not use any tools which produce swarf such as a saw or a grinder.
- Cautions to Refrigerant Pipe Ends

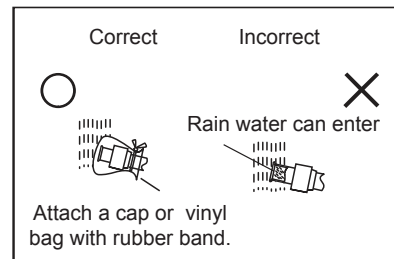
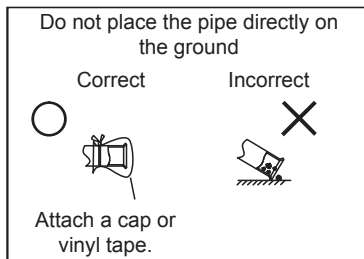
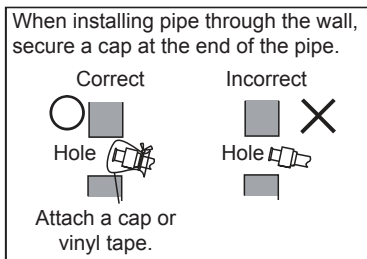

- Cautions for Piping Connection Work
- (1) Connect the indoor/outdoor units with refrigerant pipes. Fix the pipes and pay attention no to contact with weak materials such as ceiling. Otherwise, the vibration of the piping may give abnormal sounds.
 - (2) Apply refrigerant oil slightly on the sheet surface of the pipe and flare nut before flaring. And then tighten the flare nut with specified tightening torque by two spanners. Perform flaring on the liquid piping side before the gas piping side. Check the gas leakage after flaring.
- NOTE: Refrigerant oil is field-supplied. 【Model: FVC68D】
- (3) In case that temperature and humidity inside the ceiling exceed 27°C/RH80%, apply additional insulation (approx. 10mm thickness) to the accessory insulation. It prevents dew condensation on the surface of the insulation (refrigerant pipe only).
 - (4) Perform the air-tightness test (4.15MPa for the test pressure).
 - (5) Perform cold insulation work by insulating and taping the flare connection and reducer connection. Also insulate all the refrigerant pipes.
- Use two spanners when tightening the flare nut.

Apply Refrigerant Oil

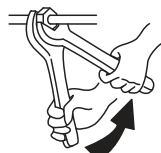
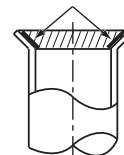

With Two Spanners

! WARNING

Do not apply excessive force to the flare nut when tightening. Or the flare nut may crack due to aged deterioration and refrigerant leakage may occur. Apply the specified tightening torque.

- Piping Thickness and Material
Use the pipe as below.

unit: mm

Diameter	R410A	
	Thickness	Material
Φ6.35	0.8	O material
Φ9.53	0.8	O material
Φ12.7	0.8	O material
Φ15.88	1.0	O material
Φ19.05	1.0	1/2H material
Φ22.2	1.0	1/2H material
Φ25.4	1.0	1/2H material
Φ28.6	1.0	1/2H material
Φ31.75	1.1	1/2H material
Φ38.1	1.35	1/2H material
Φ41.3	1.45	1/2H material
Φ44.5	1.55	1/2H material
Φ50.8	2.0	1/2H material
Φ53.98	2.0	1/2H material

4.2 Flaring and Joint

- Flaring Dimension
Perform the flaring as shown below.

unit: mm

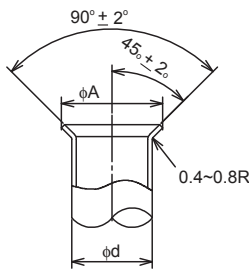

Diameter (Φd)	A ⁺⁰ / _{-0.4}
	R410A
6.35	9.1
9.53	13.2
12.7	16.6
15.88	19.7
19.05	(*)

(*)It is impossible to perform the flaring work with 1/2H material. In this case, use an accessory pipe (with a flare).

- Joint Selection
If you use 1/2H material, you can not perform the flaring work. In this case, use a joint selected from the chart below.

<Minimum Thickness of Joint (mm)>

Diameter	R410A
Φ6.35	0.5
Φ9.53	0.6
Φ12.7	0.7
Φ15.88	0.8
Φ19.05	0.8
Φ22.2	0.9
Φ25.4	0.95
Φ28.6	1.0
Φ31.75	1.1
Φ38.1	1.35
Φ41.3	1.45
Φ44.5	1.55
Φ50.8	2.0
Φ53.98	2.0

<Flare Nut Dimension B (mm)>

Diameter	R410A
Φ6.35	17
Φ9.53	22
Φ12.7	26
Φ15.88	29
Φ19.05	36

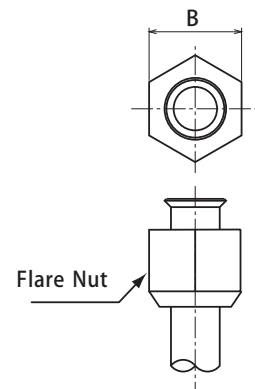

4.3 Caution to Outdoor Unit Installation

Outdoor Unit Alignment

Taking four-module combination of outdoor unit for example.

Align the outdoor units from large capacity as $A \geq B \geq C \geq D$, and outdoor Unit "A" should be located at the indoor unit side.

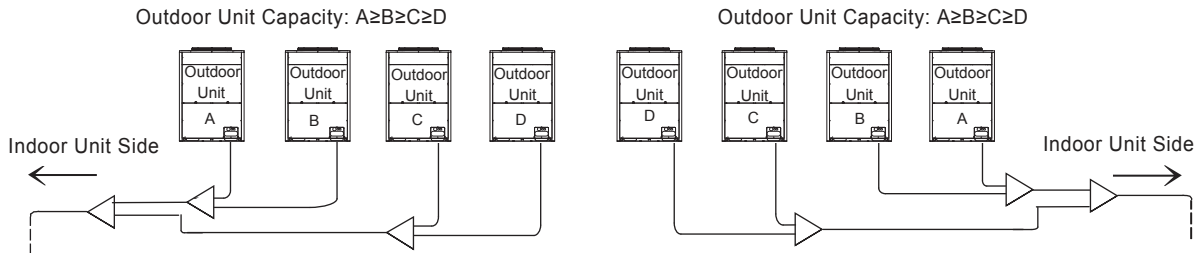

Piping Work between Outdoor Units.

(1) Piping length between manifold pipe (at outdoor unit side) and outdoor unit should be:

$$L_A < L_B < L_C < L_D < 10m.$$

Outdoor Unit Capacity: $A \geq B \geq C \geq D$

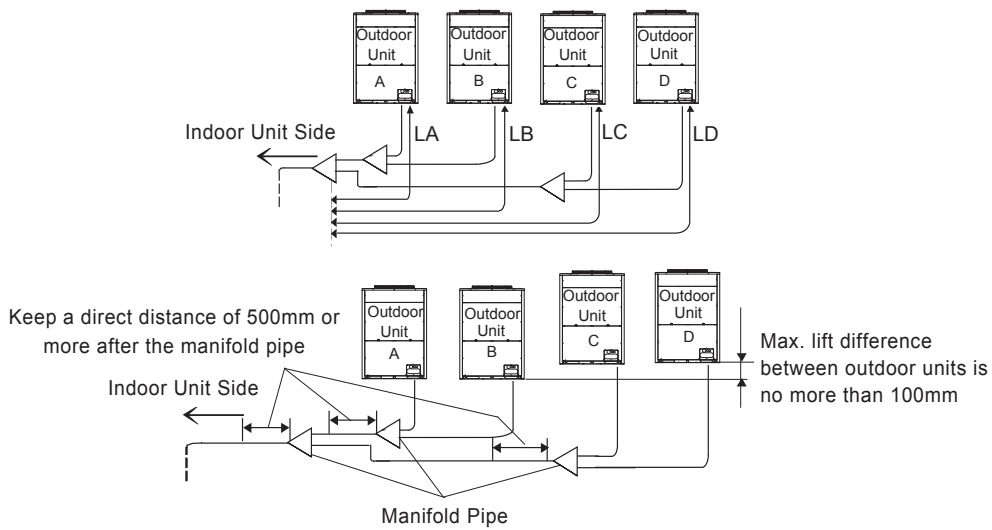

(2) Taking three-module combination of outdoor unit as an example.

Place the manifold pipe lower than the outdoor unit piping connection.

In case that the manifold pipe is placed higher than the outdoor unit piping connection, keep 300mm(max.) between the manifold pipe and the bottom of the outdoor unit. Also, provide the oil trap (min.200mm) between the manifold pipe and the bottom of the outdoor unit.

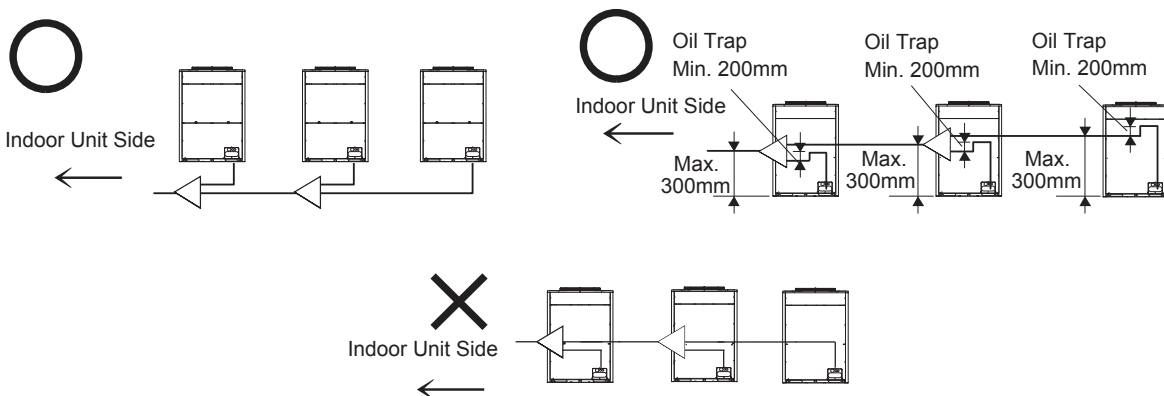

(3) In case the piping length between the outdoor is 2m or more, the oil trap should be provided for the gas pipe so that the accumulation of the refrigerant may not occur.

* Less than 2m

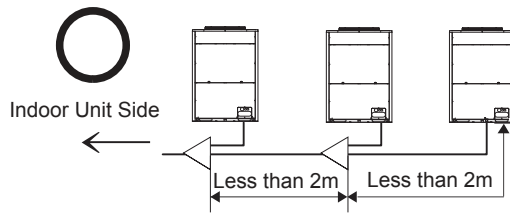

* 2m or longer

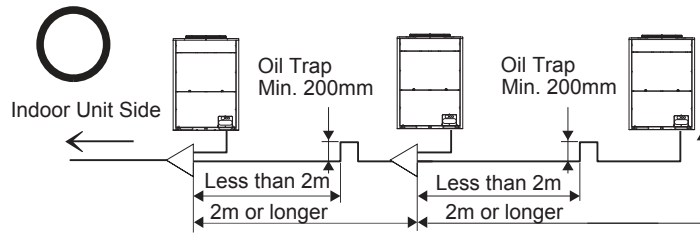

(4) Place the outdoor unit pipe horizontally or with down gradient toward indoor unit side, or refrigerant oil may accumulate in the pipe.

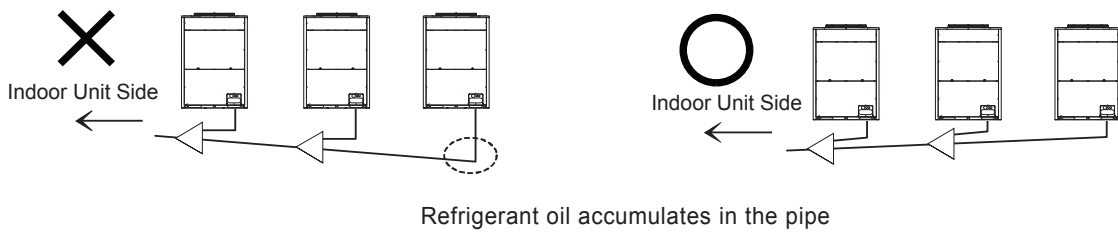

(5) For servicing, in case that the pipe is placed frontward the outdoor unit, secure a min. 500mm distance between the outdoor unit and the manifold pipe. (when the compressor is replaced, a space of min. 500mm is required.)

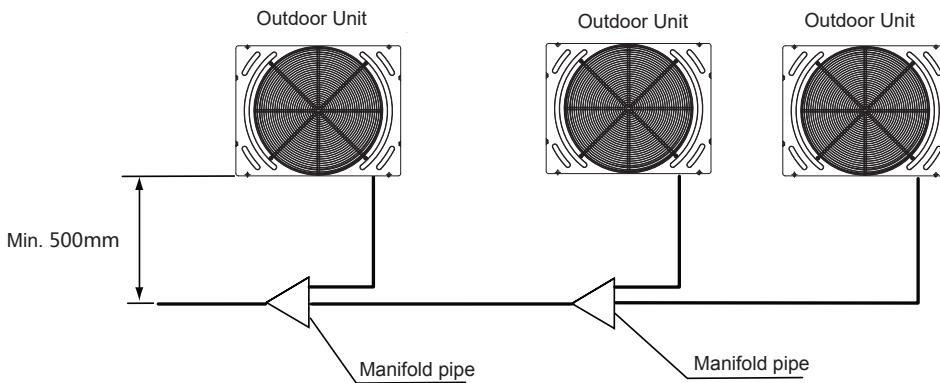

(6) Direction of manifold pipe

Place the manifold pipe horizontally towards the ground (within $\pm 15^\circ$) as shown in the figure.

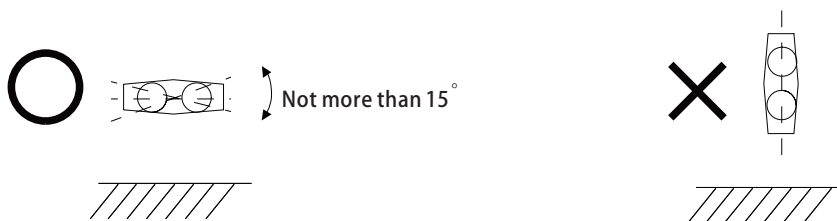

4.4 Piping Connection

Perform the piping connection for each outdoor unit.

NOTE:

Ensure that the refrigerant pipe should be connected to a unit in the same refrigerant cycle.

- Prepare the refrigerant pipe in the field for the piping work.
 - Piping Direction
Fix the pipes adequately in order to avoid vibration and excessive force to the valve.
- (1) The pipes are available to connect in three directions from the bottom base.
 Front side: gash the piping cover 1 with a cutter and connect directly through the service lid at the front unit.
 Bottom side: connect directly from the piping cover 2 on the bottom base.
 Rear side: connect from the piping cover 2 on the bottom base, then pass through the bottom base to open a hole and connect.

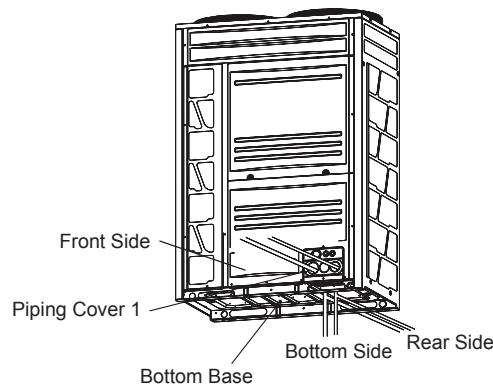

- (2) Operation of the stop valve should be performed according to Item 4.4.1.
- (3) If the piping connected from the front side, completely seal the connecting piping with insulation pipe in order to prevent from the ingress of water or snow.
- (4) If the piping connected from the bottom or rear side, completely seal the penetration part of the bottom pipe with insulation pipe in order to prevent from the ingress of water or snow.

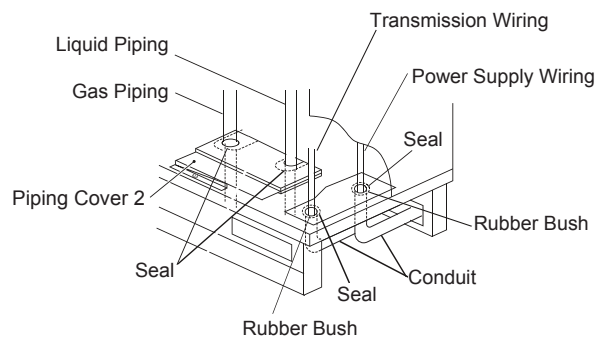

Apply insulation and check that no clearance exists.

4.4.1 Stop Valve

- (1) Make sure that all the stop valves are closed completely;
- (2) Connect a charging hose to the service port on the gas valve and release gas from the gas pipe;
- (3) Cut off the tube at the end of the cap ($\Phi 6.35$) and check that no gas exists inside the gas pipe;
- (4) Remove the stop valve cover;
- (5) Remove the cap from the brazing portion by a burner. Pay attention to the flame from the burner not to burn the stop valve body.

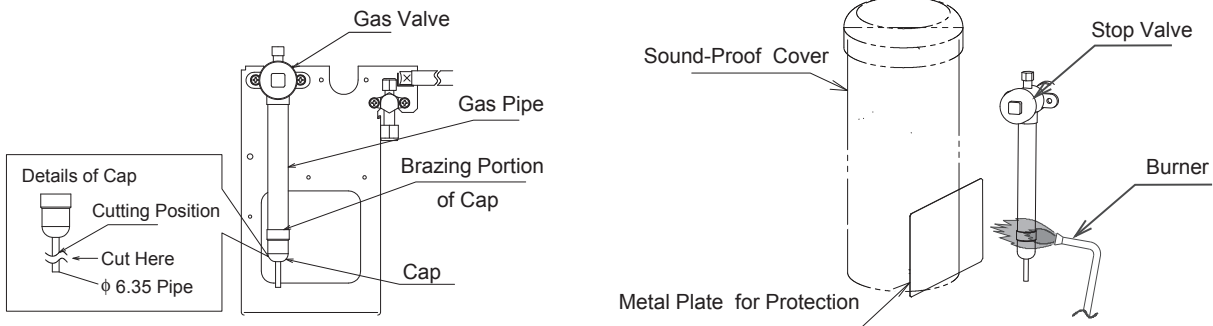

CAUTION

- Ensure that there is no gas inside the pipe when removing the cap. Otherwise, the pipe may be blown out and it may lead to injuries.
- Protect the return oil pipe and sound-proof cover of the compressor with the metal plate when using a burner.
- Stop valve is detailed below:

<Gas Valve>

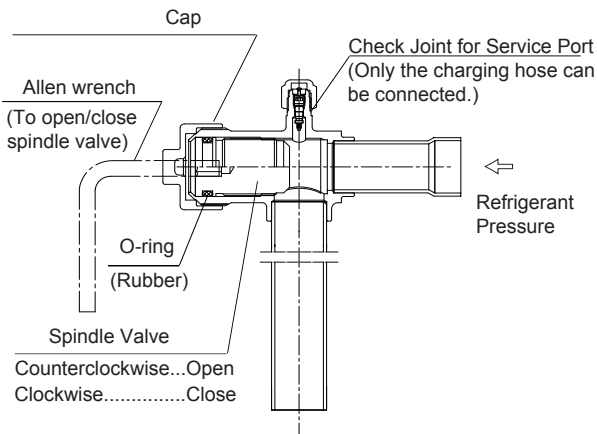

<Liquid Valve>

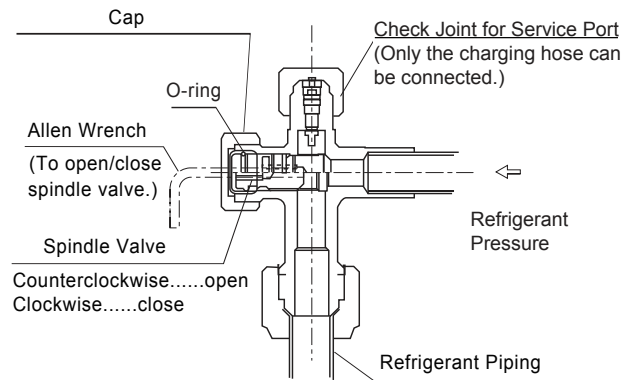

CAUTION

- Do not apply too much force to the spindle valve at the end of opening, otherwise the stop valve will be damaged.
- At the test run, fully open the spindle, or the devices will be damaged.

4.4.2 Piping Connection

- (1) Make sure that the stop valves are closed completely.
- (2) Protect the compressor and sound-proof cover with a metal plate when brazing the gas pipe as shown in Item 4.4.1. Pay attention to the flame from the burner not to burn the stop valve body.
- (3) Connect the indoor unit and the outdoor unit with refrigerant piping. Prevent the refrigerant piping from touching weak parts of the building such as wall, ceiling, etc. (The vibration of the piping may give abnormal sound).
- (4) Charge nitrogen gas into the pipe when brazing.
- (5) Insulate the gas pipe and liquid pipe completely.
- (6) Mount the piping cover after piping connection. If not, the unit may be damaged due to the ingress of snow or rainwater.

NOTES:

1. Ensure that the blind pipe of the gas stop valve (1 place) is removed firstly.
2. Refer to Item 4.2 for flaring.

- Construction Example

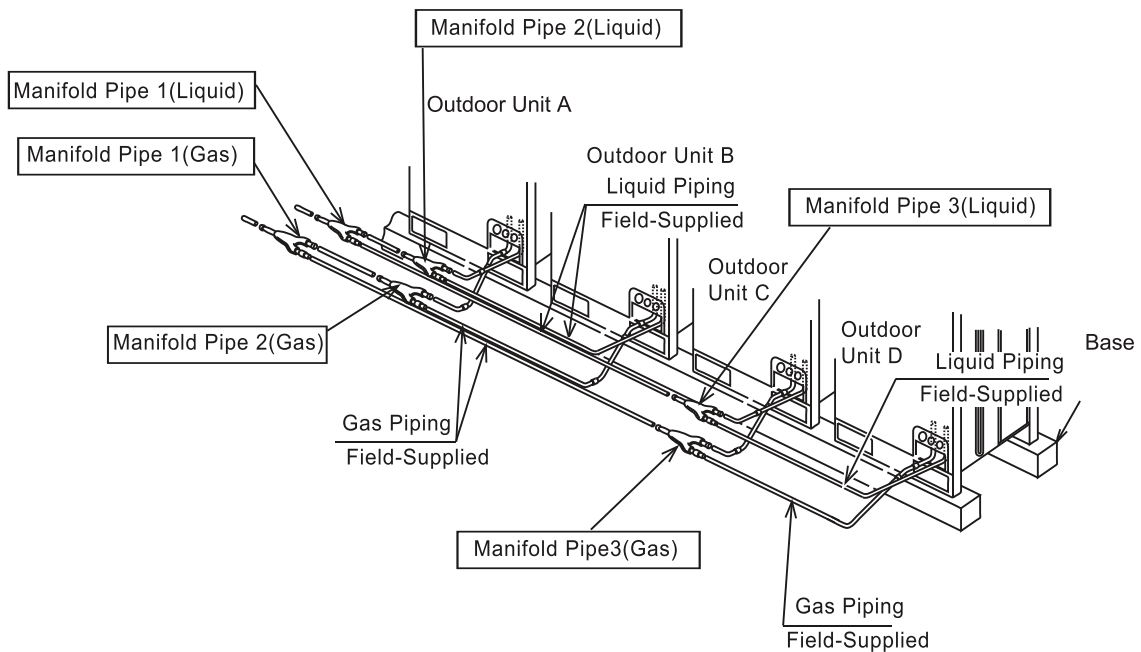

< Front Side Piping Connection >

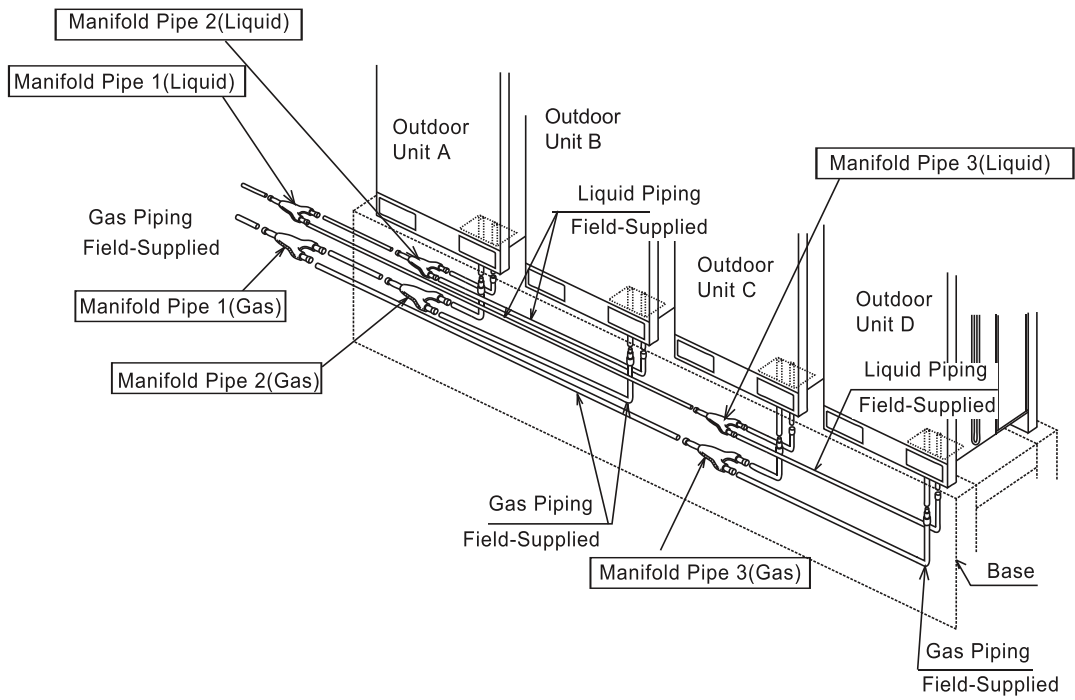

< Downward Piping Connection >

NOTE:

The figure shows the case that the refrigerant pipes are pulled out from the front side piping cover. They can be also pulled out from the bottom base hole.

5. Electrical Wiring

WARNING

- Turn OFF the main power switch to the indoor unit and the outdoor unit and wait for more than 10 minutes before electrical wiring or a periodical check.
- Check to ensure that the indoor fan and the outdoor fan have stopped before electrical wiring or a periodical check is performed.
- Protect the wires, electrical parts, etc. from rats or other small animals. If not, rats may gnaw at unprotected parts, which may lead to a fire.
- Avoid the wirings from touching the refrigerant pipes, plate edges and electrical parts inside the unit. If not, the wires will be damaged and at the worst, a fire will break out.
- Use a medium sensing speed type ELB (Earth Leakage Breaker, activation speed of 0.1 sec. or less). If not, it will lead to an electric shock or a fire.
- Fix the cables securely. External forces on the terminals could lead to a fire.
- It is forbidden to use the terminal block of air conditioner power supply to transfer the power supply. Use the power distribution box to extend the power supply wire on the inner side of the air conditioner. Pay attention to the wiring capacity calculation, otherwise the insufficient capacity may lead to a fire.
- Tighten screws according to the following torques.
 - M4: 1.0~1.3 N.m
 - M5: 2.0~2.4 N.m
 - M6: 4.0~5.0 N.m
 - M8: 9.0~11.0 N.m
 - M10: 18.0~23.0 N.m

5.1 General Check

- (1) Make sure that the field-selected electrical components (main power switches, fuse, wires, conduit connectors and wire terminals) comply with National Electrical Code (NEC).
 - Supply electrical power to each outdoor unit. An ELB, fuse and main switch should be used for each outdoor unit. If not, it will lead to a fire or electric shock.
 - The power supply for the indoor unit and outdoor unit should be provided separately. Connect a power supply wire to each indoor unit group connecting to the same outdoor unit.
- (2) Check to ensure that the power supply voltage is within $\pm 10\%$ of the rated voltage. If the power supply is excessively low, the system does not start due to the voltage drop.
- (3) Check the size of electrical wires.
- (4) In some cases, the air conditioner may not operate properly under the following cases.
 - In case that the air conditioner is supplied with the same power transformer as the device with high electricity consumption
 - In case that the power source wires for the device* and the air conditioner are located closely to each other.

* Lift, container crane, rectifier for electric railway, inverter power device, arc furnace, electric furnace, largesized induction motor and large-sized switch. For the cases mentioned above, induction surge of the power supply wire for the packaged air conditioner may occur due to a rapid change in electricity consumption of the device and an activation of switch. Therefore check the field regulations and standards before performing electrical work in order to protect the power supply wiring for the packaged air conditioner.
- (5) Check to ensure that the earth wire of the outdoor unit is connected.

5.2 Wiring



The ELB (earth leakage breaker), FUSE and S (main switch) must be installed to the each power source of outdoor unit. If not, it may lead to an electric shock or a fire. Perform the electrical work according to the regulations of each region and this manual.

NOTE:

Supply the power source of outdoor units and indoor units respectively.

- (1) Supply the power sources to each outdoor unit respectively. Power source wiring is fundamentally according to this method

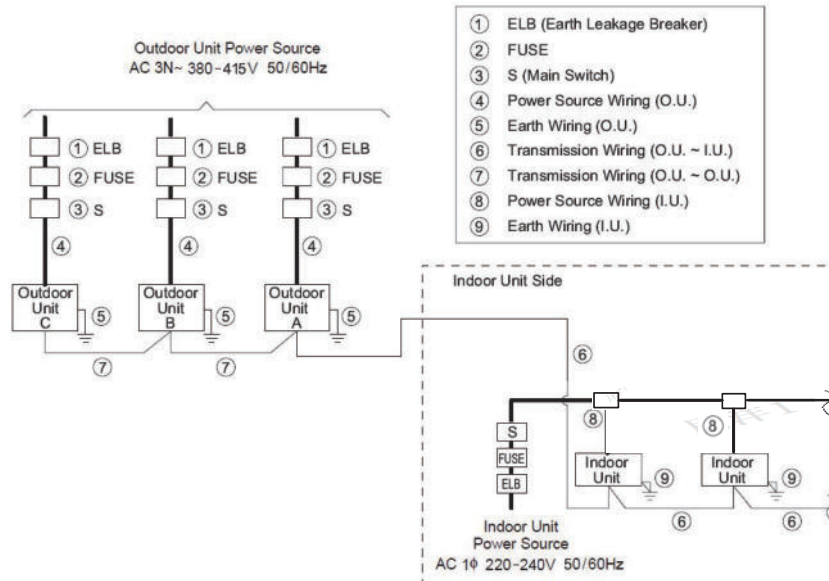

- (2) The recommended wire, ELB, switching capacity are shown in Table 5.1

Table 5.1 Field Minimum Wire Sizes for Power Source

Model (kBtu/h)	Power Supply	Max Operating Current (A)	Power Supply Line (mm ²)		Transmission Supply Line (mm ²)	ELB		Fuse (A)
			PVC*	XLPE*		Rated Current (A)	Current Sensitivity (mA)	
76	380-415V 3N~ 50/60Hz	17.1	4	2.5	0.75	20	30	20
96		24.9	6	4	0.75	32	30	32
114		25.1	6	4	0.75	32	30	32
136		31.9	10	6	0.75	40	30	40
154		33.0	10	6	0.75	40	30	40
170		36.3	10	6	0.75	40	30	40
190		45.6	16	10	0.75	50	30	50
212		53.6	25	10	0.75	63	30	63
232		56.1	25	16	0.75	63	30	63
250		67.6	25	16	0.75	80	30	80
272	69.3	25	16	0.75	80	30	80	

*The insulation material represents type:XLPE-YJV PVC-BVV.

ELB: Earth Leakage Breaker

NOTES:

- (1) Follow local codes and regulations when selecting field wires.
- (2) The wire sizes in the above table are selected based on the maximum current of the unit according to the European Standard, EN60335-1. Use the wires which are not lighter than the ordinary polychloroprene sheathed flexible cord (code designation H05RN-F).

- (3) Use a shielded cable for the transmitting circuit and ground the cable.
- (4) In the case that power cables are connected in series, add each unit's maximum current and select wires as below.
- (5) The installation and replacement of power cable shall be performed by a professional engineer.

Table 5.2 Power Wire Selection Basis

Wire Size (mm ²)	Current (A)			
	A2+PVC	A2+XLPE	B2+PVC	B2+XLPE
1.5	11.3	14.1	12.6	16.8
2.5	15.2	19.1	17.0	22.8
4	20.0	25.5	22.6	30.9
6	25.2	32.8	29.6	39.1
10	33.9	45.5	40.0	54.6
16	45.2	61.9	53.1	72.8
25	59.2	81.0	69.6	91.9
35	-	100.1	-	114.7
50	-	121.9	-	139.2

① A2 is laid in heat insulation wall; B2 is laid in a cable through box.
 ② The ambient air temperature is 40
 ③ Copper conductors must be used.
 ④ Insulation material: PVC, XLPE

Model	Scs(MVA)
76	1.36
96	1.97
114	1.99
136	2.52
154	2.61
170	2.87
190	3.61
212	4.24
232	4.44
250	5.34
272	5.48

 CAUTION

Install a multi-pole main switch with a space of 3.0mm or more between each phase.

NOTES:

- (1) When the power supply wiring is longer, select the minimum wiring size of which the voltage drop is within 2%.
- (2) Power supply voltage should be satisfied with the followings:
 - Supply voltage: within ±10% of rated voltage
 - Starting voltage: within -15% of rated voltage
 - Operating voltage: within ±10% of rated voltage
 - Imbalance between phases: within 3%
- (3) Do not connect the earth wire to the gas pipe, water pipe or lightning conductor.
 - Gas pipe: an explosion and a fire may occur when gas leaks.
 - Water pipe: there is no effect of earth wire when a hard vinyl pipe is used.
 - Lightning conductor: the earth electric potential abnormally increases when a lightning conductor is used.

5.3 Electrical Wiring Connection

Connect the electrical wirings according to the following figure.

- (1) Wrap power lines L1, L2, L3, N and Earth wire (for basic units of 76~114kBtu/h), L1, L2, L3 and N (for basic units of 136~272kBtu/h) twice around the big magnet ring in electrical accessory pouch and fix with cord clamp; then connect to Terminal L1, L2, L3, N on TB1 and earth wire connect to the terminal in the electrical control box.
- (2) Wrap transmission wire between indoor and outdoor units twice around the small magnet ring in electrical accessory pouch and fix with cord clamp, then connect to Terminal 1 and 2 of TB2 on PCB1.
As for transmission wire between outdoor units of the same refrigerant system, please connect to Terminal 3 and 4 of TB2 on PCB1.
- (3) Tighten screws on the terminal board according to the following table.

Size	Tightening Torque
M4	1.0 ~ 1.3 N · m
M5	2.0 ~ 2.4 N · m
M6	4.0 ~ 5.0 N · m
M8	9.0 ~ 11.0 N · m
M10	18.0 ~ 23.0 N · m

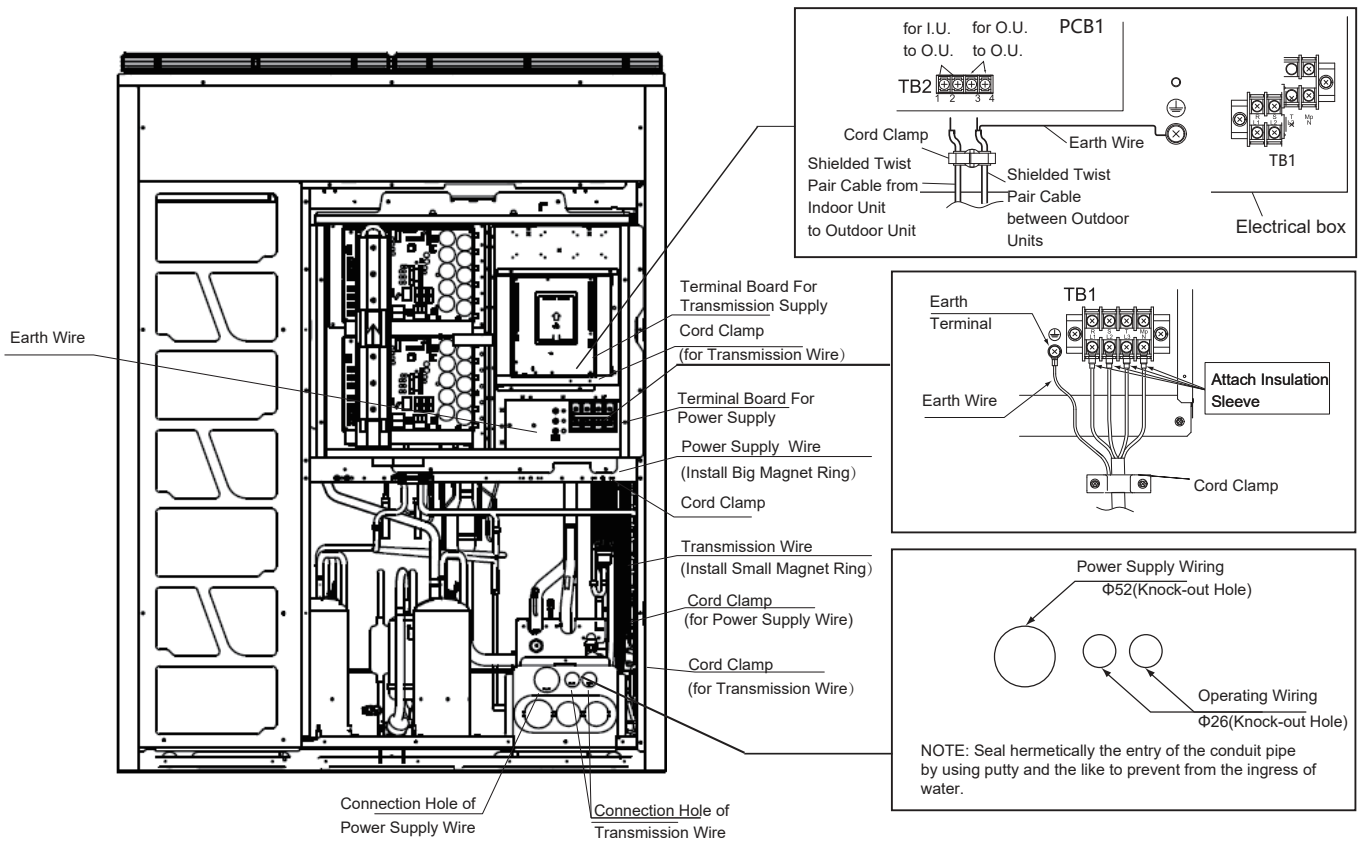

⚠ CAUTION

**Pay attention to the followings to run through the cables under the unit using conduit.
(Remove pipe cover before piping and wiring)**

1. Do not lead the power supply wiring and transmission wiring through the same conduit tube. Moreover, keep at least 50mm between the power supply wiring and transmission wiring.
2. Cut cross line at rubber bush and securely attach it to the knock-out hole for cable protection.
3. Attach the pipe cover (refer to item 4.4) to avoid entrance of rats or other small animals into the unit.
4. Avoid the wirings from touching the refrigerant pipes, plate edges and electrical parts inside the unit.
5. Completely seal the end of conduit tube with sealing materials to avoid entrance rain into the conduit tube. Make a drain hole at the lowest part of the conduit tube.

⚠ CAUTION

Tightly secure the power source wire by cord clamp inside the unit.

5.4 Electrical Wiring Connection of The System

- (1) Connect a power supply wire to each outdoor unit. Connect an ELB, fuse and main switch (S) to each outdoor unit.
- (2) Connect a power supply wire to each indoor unit to be connected to the same outdoor unit. Connect an ELB, fuse and main switch (S) to each indoor unit group.
- (3) Connect the transmission wire between indoor units and outdoor units, as shown on next page.
- (4) Connect the transmission wire in the same refrigerant cycle unit. (In case that the refrigerant pipe of indoor unit is connected to the outdoor unit, connect the transmission wire to the same indoor unit.) Connecting refrigerant pipe and transmission wire to the different refrigerant cycle systems may lead to malfunction.
- (5) Use 2-Core lead wires such as shielded twist pair cable as transmission wire. (Do not use 3-Core or over.)
- (6) Use the same kind of cables for H-NET system of the same refrigerant cycle.
- (7) The transmission wire is required to be separated from the power supply wire. Keep a distance of at least 50mm between the transmission wiring and the power supply wiring, and also a distance of min. 1.5m between the transmission wiring and power supply wiring for other electrical devices. If the above is not secured, insert the power supply wire into the metal conduit to separate from other wires.
- (8) Connect the following transmission wire to terminals 1 and 2 of TB2 in the outdoor unit A (main unit).
 - between outdoor unit and indoor unit.
 - between outdoor unit and indoor unit in other refrigerant cycles.
- (9) Do not connect the power supply wire to the terminal board for transmission wire (TB2). Printed circuit board may be damaged.
- (10) Connect the earth wire for the outdoor/indoor. The earth wiring work under the condition of 100 ohms (max.) ground resistance should be performed by the qualified person.

NOTES:

1. For the combination units (290~1088kBtu/h), DSW settings of the main and the sub are required.
 2. Alarm occurs if the transmission wires between outdoor units are connected to the terminals 1 and 2 for H-NET.
 3. In case that alarm is indicated on the LCD of main outdoor unit, follow the "7-segment" indication of the main outdoor unit checking.
 4. Perform function setting from main outdoor unit.
- < 380~415V 3N~ 50/60Hz >

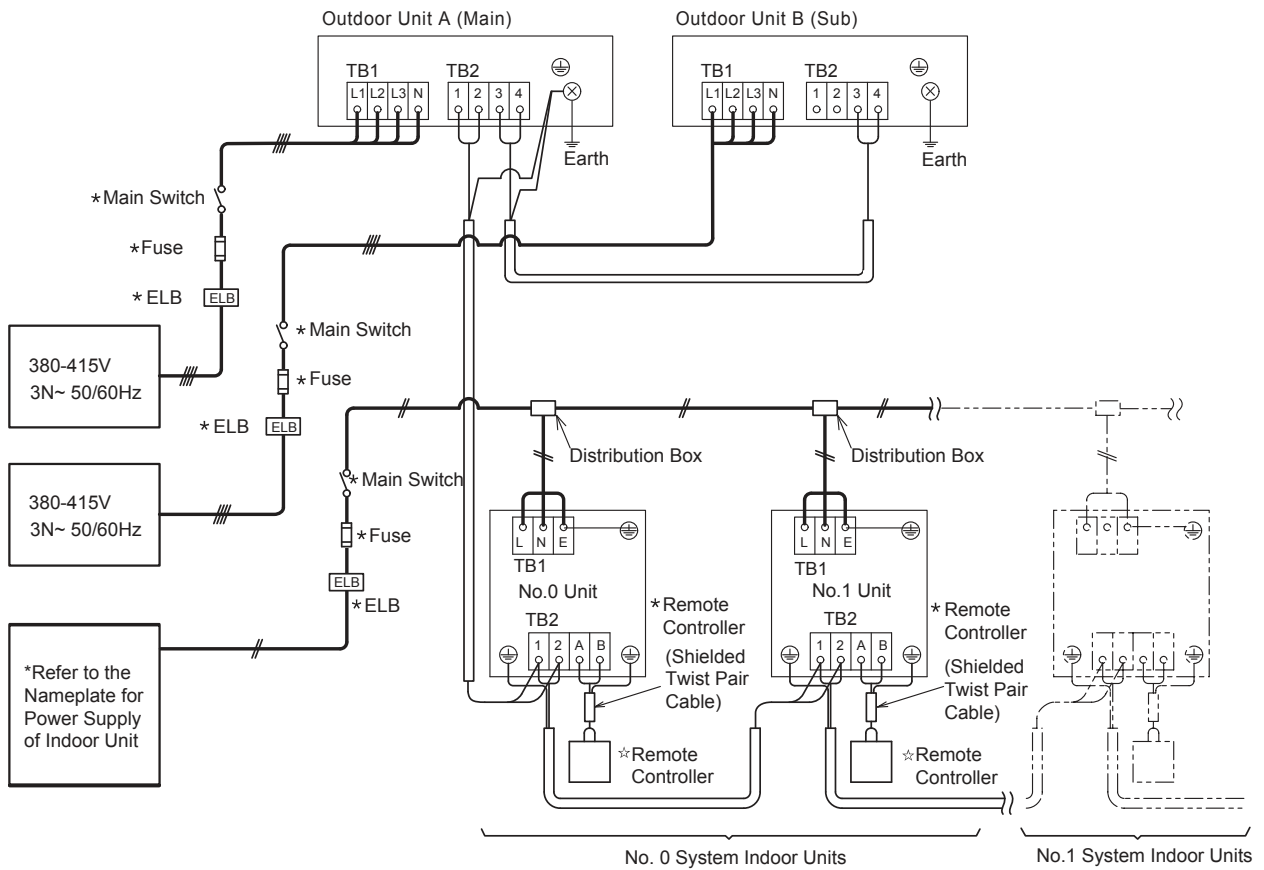

- TB : Terminal Board
- : Field Wiring
- : Transmission Line (Shielded Twist Pair Cable)
DC5V (Non-Pole Transmission Hi-NET System)
- * : Field Supplied
- ☆ : Optional Accessory

5.5 DIP Switch Setting of Outdoor Unit

TURN OFF all power sources before setting. Without turning OFF, the switches do not work and the settings are invalid. However, DSW4-No.1,2,4 can work when power supply is ON. The mark of “■” indicates the position of DIP switches.

Basic Unit (Before Shipment)	Test Run for Cooling Operation	Test Run for Heating Operation	Forced Stop for Compressors

NOTES

- Only when the main outdoor unit is set, can DSW4-No.1 and 4 work. Otherwise, they are invalid.
- By using switch DSW4, the unit starts or stops 10 to 20 seconds after the switch operates.
- Number this outdoor unit to distinguish from other outdoor units for service and maintenance. And write the number in the box on the right.
- Do not touch any other electrical parts when operating switches on the PCB.

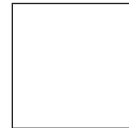

- Setting for Transmitting

It is required to set the outdoor unit numbers, refrigerant cycle Nos. and terminal resistance for this H-NET system. In case of the combination of basic units, set DSW6 as shown below.

Basic Unit (Before Shipment)	Combination of Basic Unit			
	Outdoor Unit A (No.0) (Main)	Outdoor Unit B (No.1)	Outdoor Unit C (No.2)	Outdoor Unit D (No.3)

- Setting of Refrigerant Cycle No.

In the same refrigerant cycle, set the refrigerant cycle No. for the outdoor units as shown below.

Basic Unit (Before Shipment)	DSW1	DSW8
	10 digit	1 digit

Example: In case of setting refrigerant cycle as No. 25



Turn ON No. 2 pin.



Turn ON No. 1 and No. 3 pins
(The settings in binary system shall be only valid for 0~9 and it will alarm once exceeding.)

0~9 Binary System DIP Setting Method for DSW8

0		5	
1		6	
2		7	
3		8	
4		9	

NOTES:

- DSW1 and DSW8 setting before shipment is 0. Maximum refrigerant cycle No. is 63.
- In the same refrigerant cycle, set the same refrigerant cycle No. for the outdoor unit and the indoor unit.

- Setting of Unit Display
 Before shipment, metric unit is a default setting and No.4 pin of DSW7 is set at "OFF" ; In the case that Imperial unit is needed, set the No.4 pin of DSW7 at "ON".

Basic Unit (Before Shipment)	Metric Unit	Imperial Unit

NOTES

Only when the main outdoor unit is set, can DSW7-No.7 works. Otherwise, it is invalid.

- Setting of Terminal Resistance
 Before shipment, No.1 pin of DSW10 is set at "ON". In the case that the quantity of outdoor units in the same H-NET is 2 or more, set No. 1 pin of DSW10 at "OFF" from the second refrigerant group of outdoor unit. If only one outdoor unit is used, no setting is required.

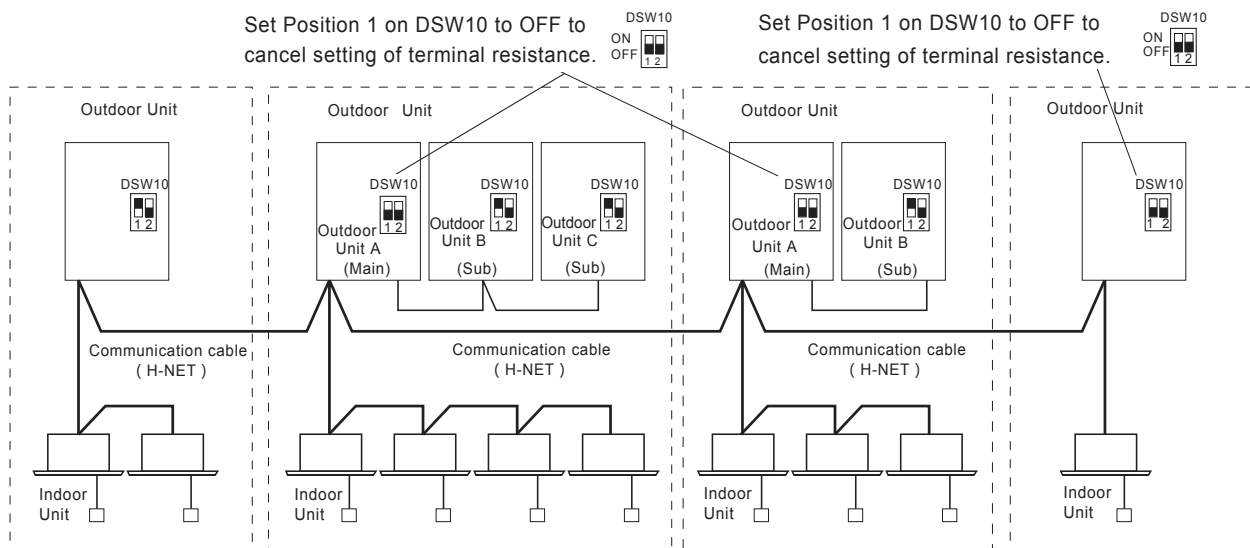
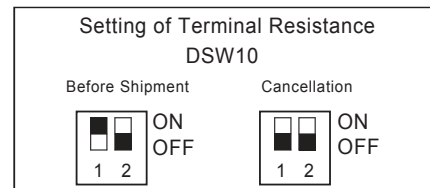

● Function Setting

External Input/Output and Function Setting

■ Start of Setting

Turn ON DSW4-No.4.
Press PSW1 for 3 seconds or more. "Menu Mode" will be indicated.

■ End of Setting

Press PSW1 for 3 seconds or more. The display indication become to normal indication. Turn OFF DSW4-No.4.

NOTE:

Release "Menu Mode" after the setting is completed. Otherwise, the air conditioner may not operate appropriately.

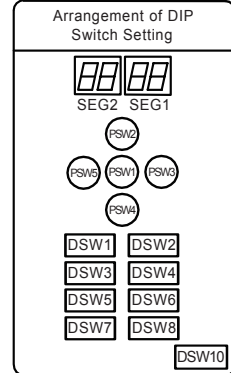
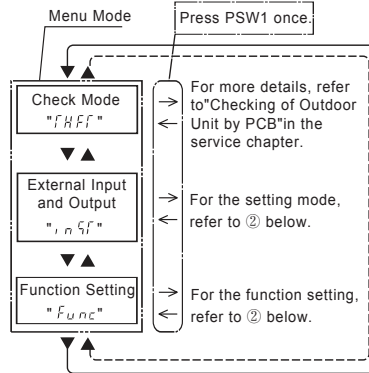

① [External Input and Output Setting]

By pressing PSW3 (▶) and PSW5 (◀), the function No. can be selected.
PSW4 (▼): forward, PSW2 (▲): backward

Fill out the selected function setting No. <Example> in the space of the table as shown. 1

Item	SEG2	SEG1	SET
1 Input Setting 1 CN17[1-2 pin]	1	1	<input type="text"/>
2 Input Setting 2 CN17[2-3 pin]	2	2	<input type="text"/>
3 Input Setting 3 CN18[1-2 pin]	3	3	<input type="text"/>
4 Output Setting 1 CN16[1-2 pin]	1	1	<input type="text"/>
5 Output Setting 2 CN16[1-3 pin]	2	2	<input type="text"/>

(Setting before shipment).

Before shipping, the input/output function settings are specified to each input/output terminal according to above table.

Setting External Input/Output Functions

Function No.	Input	Output
1	Fixing Heating Operation Mode	Operation signal
2	Fixing Cooling Operation Mode	Warning signal
3	Demand Stoppage	Compressor ON signal
4	Outdoor Fan Motor Start/Stop	Frost signal
5	Forced Stoppage	-
6	Demand Current Control 40%	-
7	Demand Current Control 60%	-
8	Demand Current Control 70%	-
9	Demand Current Control 80%	-
10	Demand Current Control 100%	-
11	Low Noise Setting 1	-
12	Low Noise Setting 2	-
13	Low Noise Setting 3	-
0	No setting	No setting

The same input/output function setting can not be set to different input/output terminals.
Or a setting of larger function number is invalid.

② [Function Setting]

By pressing PSW3 (▶) and PSW5 (◀), the setting can be changed.
PSW4 (▼): forward, PSW2 (▲): backward

Refer to the Service chapter for more details.

Fill out the selected function setting No. in the space of the table as shown. 1

Item	SEG2	SEG1	SET	Item	SEG2	SEG1	SET
1 Circulator Function at Heating Thermo-OFF	F	0	<input type="text"/>	16 Fine Adjustment of Indoor Expansion Valve Initial Opening in Heating Mode	c	0	<input type="text"/>
2 Night-Shift	n	0	<input type="text"/>	17 Low Noise Setting (In the case of low noise setting, cooling/heating operation range will be restricted.)	d	0	<input type="text"/>
3 Cancellation of Outdoor Ambient Temperature Limit	0	5	<input type="text"/>	18 Demand Function Setting	d	0	<input type="text"/>
4 Defrost for Cold Area(Change for Defrost Condition)	d	0	<input type="text"/>	19 Wave Function Setting	w	0	<input type="text"/>
5 SLo (Fan Speed) Defrost Setting	b	0	<input type="text"/>	20 Cold Draft Protection	f	0	<input type="text"/>
6 Cancellation of Hot Start	h	0	<input type="text"/>	21 Connection Setting of Fresh Air Unit or AHU	f	0	<input type="text"/>
7 Priority Capacity Mode	p	0	<input type="text"/>	22 Adjustment of Fan Rotation(for multiple installation)	f	0	<input type="text"/>
8 Compressor Frequency Control Target Value for Cooling	h	0	<input type="text"/>	23 Height Difference Setting	h	0	<input type="text"/>
9 Compressor Frequency Control Target Value for Heating	h	0	<input type="text"/>	24 Initial opening of indoor expansion valve at heating operation stoppage	f	0	<input type="text"/>
10 Indoor Expansion Valve Control Target Value for Cooling	s	0	<input type="text"/>	25 Automatic Night-Shift	n	0	<input type="text"/>
11 Indoor Expansion Valve Control Target Value for Heating	s	0	<input type="text"/>	26 Intermittent Operation of Outdoor Fan Motor	f	0	<input type="text"/>
12 Indoor Expansion Valve Opening Change for Stoppage Indoor Unit in Heating Mode	s	0	<input type="text"/>	27 ~ 31 Address Setting for VIP Indoor Unit	0	1 ~ 5	<input type="text"/>
13 Indoor Expansion Valve Opening Change for Thermo-OFF Indoor Unit in Heating Mode	s	0	<input type="text"/>	32 Capacity Offload Setting (SVA)	h	0	<input type="text"/>
14 Indoor Expansion Valve Initial Opening of Thermo-ON Indoor Unit in Heating Mode	c	0	<input type="text"/>	33 Economic Function Setting	e	0	<input type="text"/>
15 Fine Adjustment of Indoor Expansion Valve Initial Opening in Cooling Mode	c	0	<input type="text"/>	34 Enforced SLo Fan Speed for Indoor Unit	p	0	<input type="text"/>

6. Additional Refrigerant Charge

6.1 Air-Tightness Test

- (1) Check to ensure that the stop valves are closed completely before air-tightness test.
 - (a) After connecting the pipes, remove the caps of gas valve and liquid valve, then tighten the spindle valves refer to item 4.4.1.
 - (b) After the above inspection, start the air-tightness test.
- (2) Connect the indoor and the outdoor units with field-supplied refrigerant pipe. Suspend refrigerant pipe at specified points and prevent the refrigerant pipe from touching weak parts of the building such as wall, ceiling, etc. (The vibration of the piping may give abnormal sound. Pay special attention in case of short pipe length.)
- (3) Connect a manifold gauge to a vacuum pump or a nitrogen cylinder and the check joint of the stop valves with charging hoses.

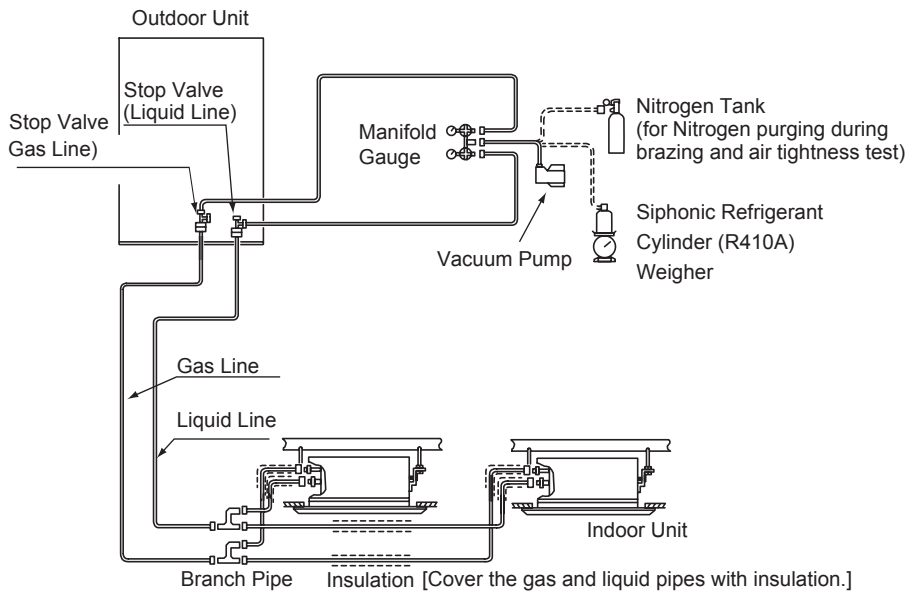

Fig. 6.1 Air-Tightness Test

CAUTION

It is necessary to confirm that the electronic expansion valve of the indoor unit is open and ensure that the piping is connected with indoor unit.

- (4) Apply nitrogen gas pressure of 4.15MPa. Do not open the stop valves.

DANGER

Be sure to use Nitrogen gas for air-tightness test. If other gases such as oxygen gas, acetylene gas or fluorocarbon gas are accidentally charged, it may lead to explosion or gas intoxication.

- (5) Check for any gas leakage at the flare nut connections or brazed parts by a gas leak tester or a foaming agent or a gas leak detector, follow the procedure below:

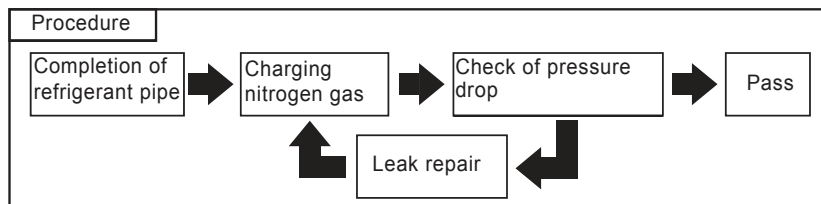

- (6) After the air-tightness test, release the nitrogen.
- (7) Mount the pipe insulation materials.

CAUTION

- Insulate the refrigerant pipes as shown in Fig.6.2.
- After connecting the refrigerant piping, seal the refrigerant pipes by using the field-supplied insulation material.
- Insulate the unions and flare nuts at the piping connections completely.
- Insulate the liquid piping and gas piping completely to avoid decreasing of performance and dewing on the surface of the pipe.

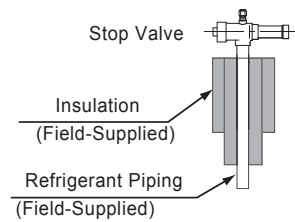

Fig. 6.2 Insulation on Pipes

6.2 Vacuuming

- (1) Connect a manifold gauge to a vacuum pump and the check joints of the stop valves with charging hoses.
- (2) Continue vacuum pumping for one to two hours until the pressure reaches -0.1MPa (-756mmHg) or lower .
After vacuum pumping, close the valves of the manifold gauge, stop the vacuum pump, and then leave it for one hour. Check to ensure that the pressure in the manifold gauge does not increase.

NOTES

1. If tools or measuring instruments come into contact with the refrigerant, use the tools or the measuring instruments exclusively for R410A.
2. If vacuum degree of -0.1MPa (-756mmHg) is not available, it is considered that there is gas leakage. Check for gas leakage once again. If there's no leakage, operate the vacuum pump for one to two hours.

6.3 Charging

- (1) After vacuum pumping, check that the gas and liquid stop valve is fully closed.
- (2) Charge the specified additional refrigerant from the check joint of liquid stop valve (tolerance: 0.5kg).
If the specified refrigerant quantity can not be charged, follow the procedure below:
 - Fully open the stop valve for gas side.
 - Operate the system at cooling mode and charge the remaining refrigerant from the check joint of the gas stop valve. At this time, the liquid stop valve is slightly opened.
- (3) After refrigerant charging, fully open the stop valve for both liquid and gas sides.
- (4) Release the charging hoses from check joints of the stop valves, then tighten the caps of the check joints.

CAUTION

- Special Attention Regarding Refrigerant Gas Leakage

Pay attention to the critical gas concentration to avoid accidental refrigerant gas leakage before installing air conditioning systems.

$$\frac{R: \text{Total Quantity of Charged Refrigerant (kg)}}{V: \text{Room Volume (m}^3\text{)}} \leq C: \text{Critical Concentration (0.42kg/m}^3\text{)}$$

- * This value should be decided according to each country's regulation such as ISO5149,EN378 and ASHRAE Standard 15. In the case that the calculated critical concentration is higher than this value, take the following actions:
 - (1) Provide a gas leakage detector and exhaust fan controlled by its gas leakage detector.
 - (2) Provide effective opening in the wall or door for ventilation to next door so that the critical gas concentration can be maintained lower than the above value. (Provide an opening with area greater than 0.15% of the floor surface at the lower part of a door.)

⚠ CAUTION

1. Maximum Permissible Concentration of HFC GAS R410A
The refrigerant R410A is an incombustible and non-toxic gas.
However, if leakage occurs and gas fills a room, it may cause suffocation.
Once leakage occurs, it is a must to take effective actions to make the concentration of R410A lower than 0.42 kg/m^3 .
2. Calculation of Refrigerant Concentration
 - (1) Calculate the total quantity of refrigerant R (kg) charged in the system connecting all the indoor units of target rooms.
 - (2) Calculate the volume of the room installing this unit V (m^3).
3. Calculate the refrigerant concentration C (kg/m^3) of the room according to the above equation.
Please follow local codes or regulations, if any.

7. Test Run

Test run should be performed according to Item 7.2. And use Table 7.1 for recording test run.

WARNING

- Do not operate the system until all the check points have been cleared.
- As for the test run of indoor unit, please refer to "Installation & Maintenance Manual" attached to the indoor unit.

7.1 Before Test Run

- (1) Check to ensure that the refrigerant piping and transmission between outdoor and indoor units are connected to the same refrigerant cycle. If not, it will lead to an abnormal operation and a serious accident. Check that the DIP switch setting of the refrigerant cycle number and the unit number for the indoor units is applicable to the system. Confirm that the DIP switch setting on the printed circuit board of the indoor units and the outdoor units are correct. Especially pay attention to the setting of lift between indoor units and outdoor units, the refrigerant No. and the terminal resistance.
- (2) Check to ensure that the electrical resistance is more than 1MΩ, by measuring the resistance between ground and the terminal of the electrical parts. If not, do not operate the system until the electrical leakage is located and repaired (Refer to "Caution to Insulation Resistance" for details.). Do not impress voltage on the terminals for transmission.
- (3) Check to ensure that each wire, L1, L2, L3 and N, is correctly connected at the power source. Otherwise the unit does not work and the remote control switch will indicate the alarm code "05". In this case, check and change the phase of the power source according to the attached sheet on the reverse side of the service cover.
- (4) Check to ensure that the switch on the main power source has been ON for more than 4 hours to warm up the compressor oil by crankcase heater. When powered up, the outdoor units will not operate (Stoppage Code d1-22) immediately if it is in protection status due to low compressor oil temperature.
In case of operating within 2 hours, release the protection control as follows:
 - Supply power to the outdoor unit.
 - Wait for 30 seconds.
 - Hold PSW5 on the outdoor PCB for more than 3 seconds in order to release the d1-22.
 - In case of using remote control switch to release, hold "Air Flow" and "Auto Louver" simultaneously for 3 seconds.
- (5) Main Unit Label
In case of the combination of basic units, attach the main unit label to a visible spot of the main unit (outdoor unit A), so that the outdoor unit A can be identified easily. Do not attach the main label to the sub unit (outdoor unit B, C and D).

CAUTION

Caution to Insulation Resistance:

If total unit insulation resistance is lower than 1MΩ, the compressor insulation resistance may be low due to retained refrigerant in the compressor. This may occur if the unit has not been used for a long period.

1. Disconnect the cables to the compressors and measure the insulation resistance of the compressors. If the resistance value is over 1MΩ, then insulation failure has occurred to other electrical parts.
2. If the insulation resistance is less than 1MΩ, disconnect the compressor cables from the inverter PCB. Then, turn on the main power to apply current to the crankcase heater. After applying current for more than 3 hours, measure insulation resistance again. (Depending on the air conditions, pipe length or refrigerant conditions, it may be necessary to apply the current for a longer period of time.) Check the insulation resistance and reconnect the compressor.

If the leakage breaker is activated, check the recommended size shown in Table 5.1.

CAUTION

1. Confirm that field-supplied electrical components (main switch fuse, fuse-free breaker, earth leakage breakers, wires, conduit connectors and wire terminals) have been properly selected according to the electrical data given in the Handbook of the unit and ensure that the components comply with national and local codes.
2. Use shielded wires (>0.75mm²) for field wiring to protect electrically noise obstacle. (total length of shielded wire shall be less than 1000m, and size of shielded wire shall comply with local codes.)

7.2 Test Run

- (1) Check to ensure that the stop valves of the outdoor unit are fully opened and then start the system.
In case of the combination of basic units, check that the stop valves of all the connected outdoor units are fully opened.
- (2) Perform the test run of indoor units one by one sequentially and then check the accordance of the refrigerant piping system and electrical wiring system. (If the multiple indoor units operates simultaneously, the system accordance can not be checked.)
- (3) Perform the test run according to the following procedure. Ensure that the test run is carried out without any problem. NOTE: In case of 2-remote control switch (main and sub), firstly perform the test run of the main remote control switch.

a) Set to "TEST RUN" mode by holding the "MODE" and "CHECK" on controller simultaneously for at least 3 seconds.

→ "TEST RUN" is displayed on the LCD.

The total number of the indoor units connected is indicated on the LCD.

05 unit

← Example when 5 indoor units are connected.

- Regarding other optional remote control switches (wireless remote control or half-size remote control), follow "Installation & Maintenance Manual" attached to each optional remote control switch and perform test run.
- In case that the multiple indoor units operates simultaneously controlled by one remote control switch, the connected number of indoor unit is indicated on LCD.
In case that the indicated number is not correct, the auto-address function is improper due to incorrect wiring, electric noise or etc. Turn OFF the power supply and correct the wiring after checking the following points; (Do not repeat turning ON and OFF within 10 seconds.)
 - * power supply of indoor unit is not turned ON or incorrect wiring.
 - * incorrect cabling between indoor units or incorrect connection of controller cable
 - * incorrect setting of rotary switch and DIP switch (overlapped setting) on the indoor units' PCB.

b) Set the operation mode by pressing "MODE".

c) Press "RUN/STOP" switch.

→ The operation lamp will be turned ON before the test run starts.

2-hour OFF Timer will be set automatically, and "OFF Timer" and "2HR" will be indicated on LCD. Although the air flow initial setting is "HI", the setting can be changed.

- Check the operation range according to page I.
 - * Do not touch any of the parts by hand at the discharge side, since the compressor chamber and the pipes at the discharge side are heated up to 90°C above.
 - * DO NOT PRESS THE MAGNETIC SWITCH(ES). It will lead to a serious accident.
 - Do not touch any electrical components within 10 minutes after turning OFF the main switch.
 - Check that the refrigerant piping setting and electrical wiring setting are for the same system, by operating the indoor unit one by one.
- d) Press "AUTO LOUVER" switch and check that the louver is activated normally without abnormal sound. Press "AUTO LOUVER" again so that the louver will stop. If there is abnormal sound, remove the panel and adjust the fitting condition of connection parts in the panel corner cover. Ensure that the panel is mounted correctly to the unit body, otherwise the panel may be deformed.
- e) The temperature control will be invalid though the protection device will be activated during the test run. If alarm occurs, find out the cause of abnormality according to Service chapter. And again perform the test run after solving the problems.
- f) According to the label "Checking of Outdoor Unit by 7-segment Display on PCB1" attached to the rear side of the front cover of the outdoor unit, inspect temperature, pressure, operation frequency, and connected indoor unit numbers by the 7-segment displays.
- g) To end the test run, wait for 2 hours or press "RUN/STOP" again.

Table 7.1 Test Run and Maintenance Record

MODEL:	SERIAL. No.	COMPRESSOR MFG.
CUSTOMER'S NAME AND ADDRESS:		No. DATE:
THE RESULT OF ALL PERIODIC ROUTINE TESTS:		
1. Is the rotation direction of the indoor fan correct?		<input type="checkbox"/>
2. Is the rotation direction of the outdoor fan correct?		<input type="checkbox"/>
3. Are there any abnormal compressor sounds?		<input type="checkbox"/>
4. Has the unit been operated at least twenty (20) minutes?		<input type="checkbox"/>
5. Check room temperature:		
Inlet: No. 1	DB/WB °C	No. 2 DB/WB °C
Outlet: <u> </u>	<u> </u> °C	<u> </u> °C
Inlet: No. 3	DB/WB °C	No. 4 DB/WB °C
Outlet: <u> </u>	<u> </u> °C	<u> </u> °C
Inlet: No. 5	DB/WB °C	No. 6 DB/WB °C
Outlet: <u> </u>	<u> </u> °C	<u> </u> °C
6. Check outdoor ambient temperature:		
Inlet: <u> </u>	DB °C	<u> </u>
Outlet: <u> </u>	WB °C	<u> </u>
7. Check refrigerant temperature:		8. Check pressure:
Liquid Temperature: Discharge <u> </u>	°C	Discharge Pressure: <u> </u>
Gas Temperature: <u> </u>	°C	Suction Pressure: <u> </u>
9. Check voltage:		
Rated Voltage: <u> </u>	V	
Operating Voltage: <u> </u>	L1-L2 V,	L1-L3 V, L2-L3 V
Starting Voltage: <u> </u>	V	
Phase unbalance: $1 - \frac{V}{V_m} =$ <u> </u>		
10. Check compressor input running current:		
Input: <u> </u>	kW	
Running current: <u> </u>	A	
11. Is the refrigerant charge adequate?	Starting Voltage: <input type="checkbox"/>	
12. Do the operation control devices operate correctly?	<input type="checkbox"/>	
13. Do the safety devices operate correctly?	<input type="checkbox"/>	
14. Has the unit been checked for refrigerant leakage?	<input type="checkbox"/>	
15. Is the unit clean inside and outside?	<input type="checkbox"/>	
16. Are all cabinet panels fixed?	<input type="checkbox"/>	
17. Are all cabinet panels free from rattles?	<input type="checkbox"/>	
18. Is the filter clean?	<input type="checkbox"/>	
19. Is the heat exchanger clean?	<input type="checkbox"/>	
20. Are the stop valves open?	<input type="checkbox"/>	
21. Does the drain water flow smoothly from the drain pipe?	<input type="checkbox"/>	
22. Are the components of the system changed and replaced?	<input type="checkbox"/>	

SERVICE

1. Troubleshooting

1.1 Initial Troubleshooting





1.1.1 Checking of Electrical Wiring and Power Source

No.	Check Item	Check Method
1	Is power source breaker or fuse blown out?	Check the voltage (secondary side) of the breaker and also check the conductivity of fuse by a tester.
2	Is voltage at secondary side of transformer correct?	Disconnect connection at the secondary side of the transformer and measure voltage by a tester.
3	Is wiring firmly fixed or correctly connected?	<p>Check that the following wiring connections on O.U./I.U. PCBs are not loosened.</p> <ul style="list-style-type: none"> • The connections for thermistors • The connections for the remote control switch cable • The connections for transformer • Each connection for power source line <p>Check that the wiring connections on O.U./I.U. PCBs are not loosened or misconnected on the site according to "Electrical Wiring Diagram"</p>

Refer to installation manual for details.

1.1.2 Checking of Rotary Switch and Dip Switch Setting

TURN OFF all power sources before setting. Without turning OFF, the switches do not work and the settings are invalid. However, DSW4-No.1,2,4 can work when power supply is ON. The mark of "■" indicates the position of DIP switches.

Basic Unit (Before Shipment)	Test Run for Cooling Operation	Test Run for Heating Operation	Forced Stop for Compressors
			

NOTES

1. Only when the main outdoor unit is set, can DSW4-No.1 and 4 work. Otherwise, they are invalid.
2. By using switch DSW4, the unit starts or stops 10 to 20 seconds after the switch operates.
3. Number this outdoor unit to distinguish from other outdoor units for service and maintenance. And write the number in the box on the right.
4. Do not touch any other electrical parts when operating switches on the PCB.

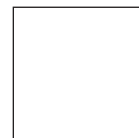

Inverter PCB and Fan Controller

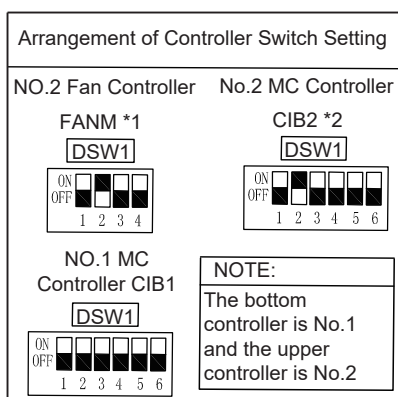

NOTE:

- *1: This setting is only effective for single-compressor and double-fan system.
- *2: This setting is only effective for double-compressor and double-fan system.

Outdoor Unit PCB

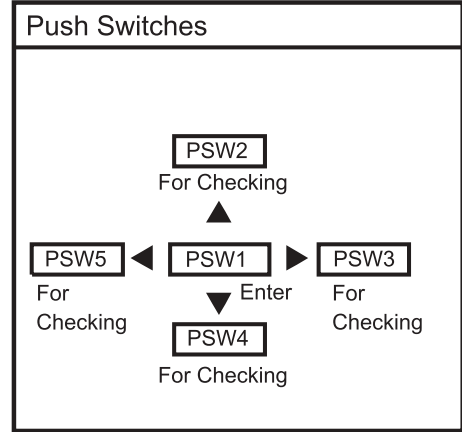
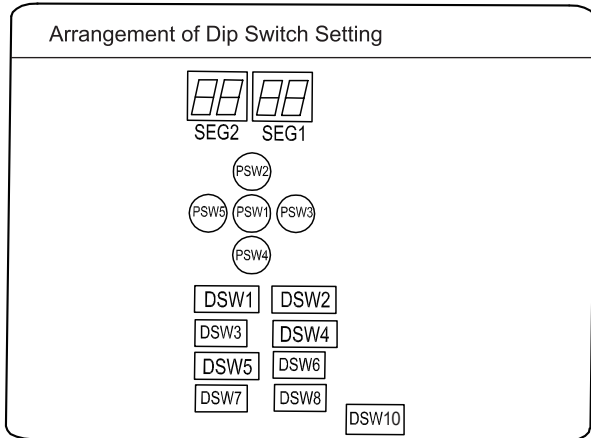

DSW1/ DSW8	Ref. Cycle No. Setting	Setting is required.
Setting Before Shipment		
DSW1 Tens Digit	DSW8 Last Digit	

DSW2	Capacity Setting	Setting is required
76	96	114
136	154	170
212	232	250
		272

DSW4	Test Operation and Service Setting	Setting is Required for Test Operation and Operating Compressor
Setting before Shipment	Test Cooling Operation	Test Heating Operation
		Compressor Forced Stop

DSW5	Emergency Operation Setting	No Setting is required
Setting before Shipment	Except No. 1 Comp. Operation	Except No. 2 Comp. Operation
	Cycle System Simulation	High static pressure setting

DSW6	Outdoor Unit No. Setting	Setting is required
Single Setting (Setting before Shipment)	<p>IMPORTANT NOTICE</p> <p>The outdoor unit is not single, the combination setting is necessary. Be sure to do this setting.</p>	
Combination Setting	No. 0 Unit	No. 1 Unit
	No. 2 Unit	No. 3 Unit

DSW7	Power Supply Setting
Metric Unit Setting before Shipment	Imperial Unit

DSW10	Transmission Setting	Setting is required for cancellation of end resistance
Setting before Shipment	Cancellation of End Resistance	

DSW3	Unit model setting	Setting is required
HKFXE		

1.1.3 Checking by 7-Segment Display

- Simple Checking by 7-Segment Display

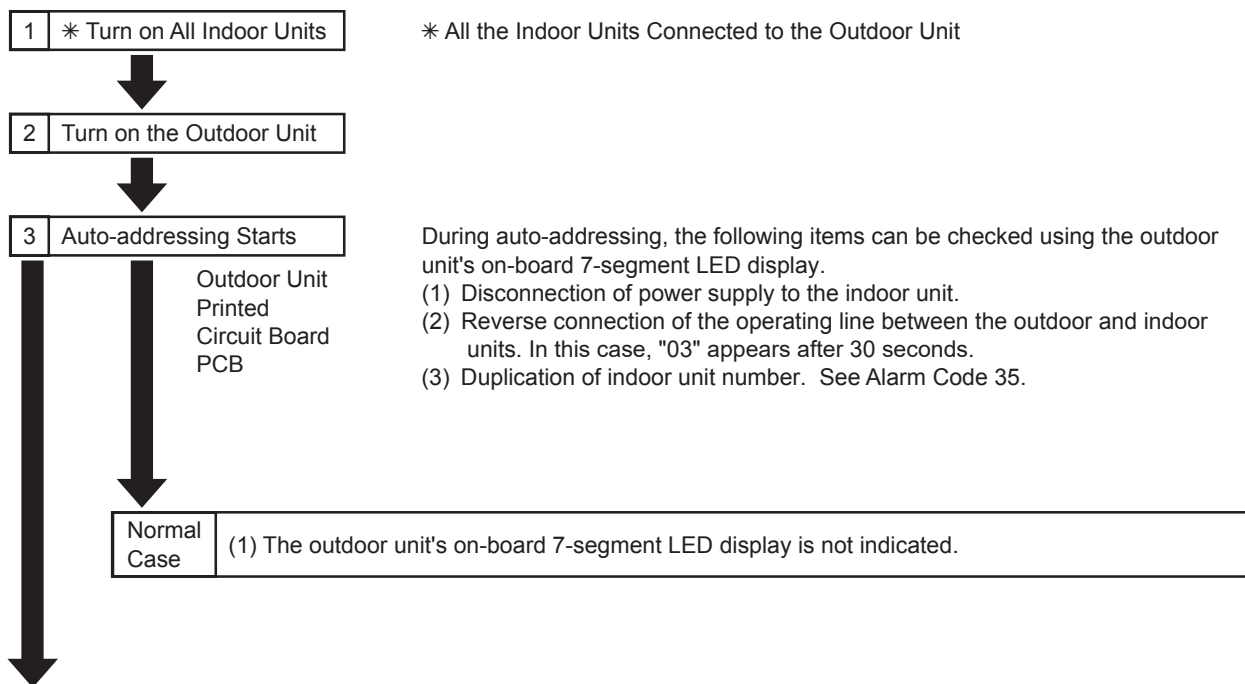

(2) The outdoor unit's on-board 7-segment LED display indicates the followings if there is something wrong.

(A) Alarm code will be displayed on the 7-segment when alarm is received from indoor unit in normal mode. As for the following alarm codes, however, alarm code will be displayed on the 7-segment when alarm is detected by outdoor unit itself.

- Alarm Code "03" (Abnormal Transmission between Indoor Unit and Outdoor Unit)
- Alarm Code "35" (Incorrect Indoor and Outdoor Unit No. Setting)

(B) Alarm code of smaller indoor unit address No. will be displayed when alarm is received from multiple indoor units.

(C) The following 7-segment is displayed and flashed every 0.5 seconds.

SEG2

SEG1

Alarm Code

(D) SEG1 and SEG2 are as follows.

7-Segment Display	Dotted Indication	Remarks
<p><In Case of Unit No. 63, Alarm Code "01"></p> <p>SEG2: Indoor Unit No. (0~63) SEG1: Alarm Code</p> <div style="display: flex; justify-content: space-around; align-items: center;"> <div style="text-align: center;"> <p>SEG2</p> <p>Indoor Unit No.</p> </div> <div style="text-align: center;"> <p>SEG1</p> <p>Alarm Code</p> </div> </div>	<p>SEG2</p> <p>Dotted Indication</p>	<p>In the case that 2 refrigerant cycle groups exist, one refrigerant cycle group is shown without dotted indication. The other refrigerant cycle group is shown with dotted indication.</p>

1.1.4 Checking of Alarm Code History

Alarm code history is indicated in the following order while the check mode is displayed.

“no01” (latest) ←→ history data ~ “no15” (oldest) ←→ history data

Refer to the figure below as an example.

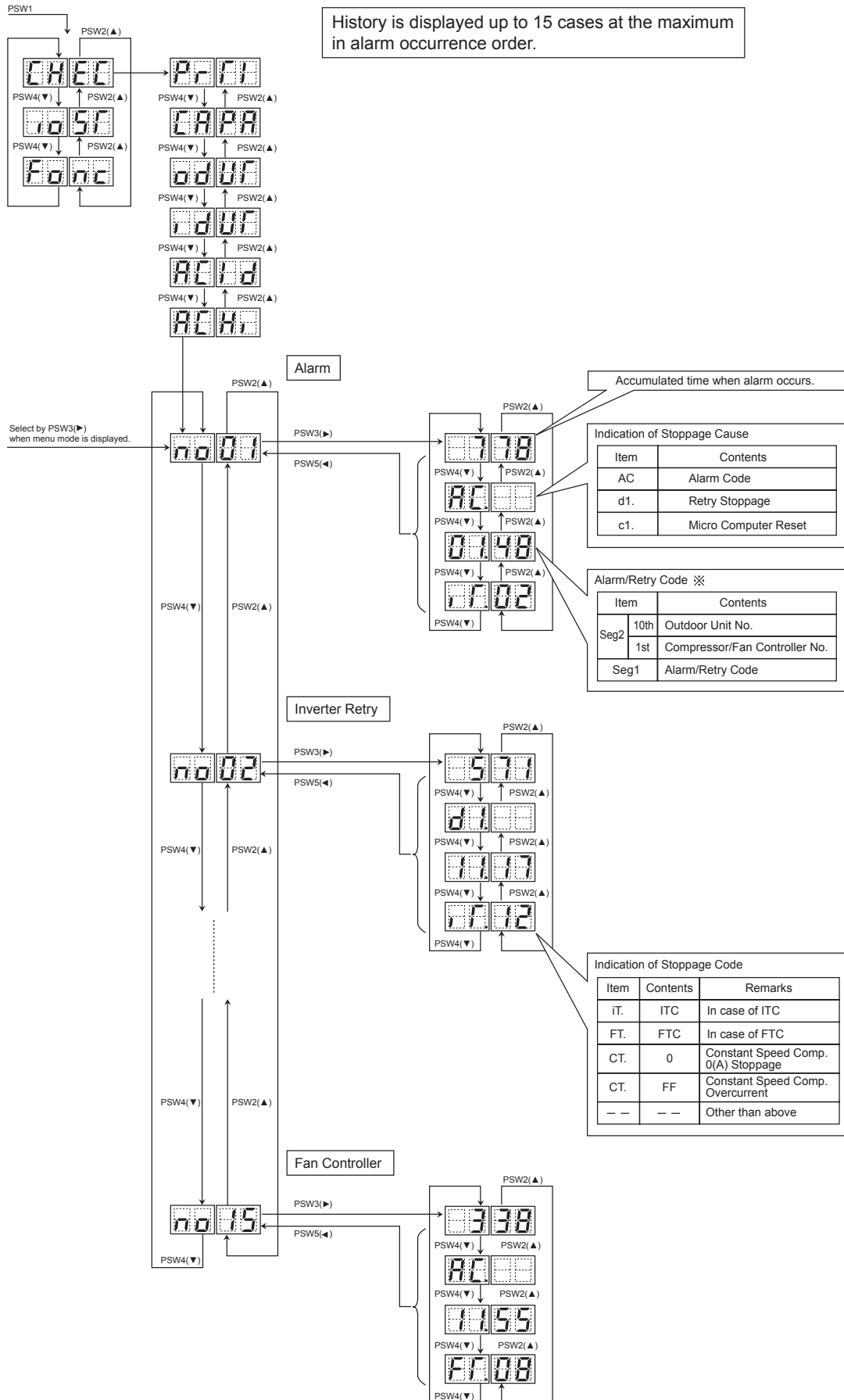

(1) Register of Alarm Code History

Cause of Stoppage (Alarm Code or Stoppage Code)	Contents	Indication of Alarm Code History					
		Time	*Alarm	Alarm Code			Alarm Code or Stoppage Code
				O.U. Unit No.	Comp. No.	Fan No.	
02	Activation of protection device	Accumulated Time	AC.	○	○		--
03	Abnormality transmitting between indoor units and outdoor units	Accumulated Time	AC.				--
04	Abnormality transmitting between inverter PCB and outdoor unit PCB	Accumulated Time	AC.	○	○		--
04.	Abnormality transmitting between fan controller and outdoor unit PCB	Accumulated Time	AC.	○		○	--
05	Abnormality of power supply phase	Accumulated Time	AC.	○			--
06	Abnormality of inverter voltage	Accumulated Time	AC.	○	○		iTC
d1-18		Accumulated Time	d1.	○	○		iTC
06.	Abnormality of fan controller voltage	Accumulated Time	AC.	○		○	FTC
07	Decrease in discharge gas superheat	Accumulated Time	AC.	○	○		--
d1-16		Accumulated Time	d1.	○	○		--
08	Increase in discharge gas temperature at the top of compressor	Accumulated Time	AC.	○	○		--
d1-15		Accumulated Time	d1.	○	○		--
0A	Abnormality transmitting between outdoor units	Accumulated Time	AC.				--
0b	Incorrect outdoor unit address setting	Accumulated Time	AC.				--
0c	Incorrect outdoor main unit setting	Accumulated Time	AC.				--
21	Abnormality of high pressure sensor	Accumulated Time	AC.	○			--
22	Abnormality of thermistor for outdoor air temperature	Accumulated Time	AC.	○			--
23	Abnormality of thermistor for discharge gas temp. on top of compressor	Accumulated Time	AC.	○	○		--
24	Abnormality of thermistor for outdoor unit heat exchanger liquid pipe (Te/Tchg)	Accumulated Time	AC.	○		Thermistor Signal Te: E Tchg: C	--
25	Abnormality of thermistor for outdoor unit heat exchanger gas pipe (TG/TbG)	Accumulated Time	AC.	○		Thermistor Signal TG: G TbG: b	--
29	Abnormality of low pressure sensor	Accumulated Time	AC.	○			--
31	Incorrect capacity setting of indoor unit and outdoor unit	Accumulated Time	AC.				--
35	Incorrect indoor unit No. setting	Accumulated Time	AC.				--
36	Incorrect indoor unit combination	Accumulated Time	AC.				--
38	Abnormality of picking up circuit for protection in outdoor unit	Accumulated Time	AC.	○			--
3A	Abnormality of outdoor unit capacity	Accumulated Time	AC.				--
3b	Incorrect setting of outdoor unit model combination or voltage	Accumulated Time	AC.				--
3d	Abnormality transmitting between main unit and sub unit(s)	Accumulated Time	AC.				--
43	Abnormality of low compression ratio	Accumulated Time	AC.	○			--
d1-11		Accumulated Time	d1.	○			--
44	Abnormality of low-pressure increase	Accumulated Time	AC.	○			--
d1-12		Accumulated Time	d1.	○			--
45	Abnormality of high-pressure increase	Accumulated Time	AC.	○			--
d1-13		Accumulated Time	d1.	○			--
46	Activation of high-pressure decrease protection device (Vacuum operation protection)	Accumulated Time	AC.	○			--
d1-26		Accumulated Time	d1.	○			--
47	Activation of low-pressure decrease protection device (Vacuum operation protection)	Accumulated Time	AC.	○			--
d1-15		Accumulated Time	d1.	○			--
48	Activation of inverter overcurrent protection device	Accumulated Time	AC.	○	○		iTC
d1-17		Accumulated Time	d1.	○	○		iTC
51	Abnormality of inverter current sensor	Accumulated Time	AC.	○	○		iTC
d1-17		Accumulated Time	d1.	○	○		iTC
53	Inverter error signal detection	Accumulated Time	AC.	○	○		iTC
d1-17		Accumulated Time	d1.	○	○		iTC
54	Abnormality of inverter fin temperature	Accumulated Time	AC.	○	○		iTC
d1-17		Accumulated Time	d1.	○	○		iTC

*(Details of Alarm)

AC.: Alarm

d1.: Retry

Ci.: Control Information

iTC: Inverter Stoppage Code;

FTC: Fan Controller Stoppage Code

Cause of Stoppage (Alarm Code or Stoppage Code)	Contents	Indication of Alarm Code History					Alarm Code or Stoppage Code
		Time	*Alarm	Alarm Code			
				O.U. Unit No.	Comp. No.	Fan No.	
55	Inverter failure	Accumulated Time	AC.	○	○		iTC
d1-18		Accumulated Time	d1.	○	○		iTC
56	Abnormality in fan motor location detecton	Accumulated Time	AC.	○		○	FTC
57	Activation of fan controller protection device	Accumulated Time	AC.	○		○	FTC
58	Abnormality of fan controller	Accumulated Time	AC.	○		○	FTC
5A	Abnormality of Fan Controller Fin Temperature	Accumulated Time	AC.	○		○	FTC
5b	Activation of Overcurrent Protection	Accumulated Time	AC.	○		○	FTC
5c	Abnormality of Fan Controller Sensor	Accumulated Time	AC.	○		○	FTC
EE	Compressor protection alarm	Accumulated Time	AC.				--
A1	Abnormality of Active Filter	Accumulated Time	AC.	○			--
A6	Abnormality of refrigerant cooling module temperature	Accumulated Time	AC.	○			--
d1-42		Accumulated Time	d1.	○			--
b5	Incorrect setting of indoor unit connection number	Accumulated Time	AC.				--
d1-05	Instantaneous power failure	Accumulated Time	d1.				--
d1-18	Abnormality of inverter and other	Accumulated Time	d1.				iTC
d1-26	Abnormality of high pressure decrease	Accumulated Time	d1.				--
d1-32	Retry stoppage by indoor unit auto address setting	Accumulated Time	d1.				--
Control Information	Micro-computer reset by abnormality of inverter transmission	Accumulated Time	Ci.				1
	Micro-computer reset by abnormality of fan controller transmission	Accumulated Time	Ci.				2
	Micro-computer reset by abnormality of indoor unit transmission	Accumulated Time	Ci.				3
	Micro-computer reset by abnormality transmitting between outdoor unit and outdoor unit	Accumulated Time	Ci.				4
	Micro-computer reset for abnormality of control state	Accumulated Time	Ci.				6

*(Details of Alarm)

AC.: Alarm

d1.: Retry

Ci.: Control Information

iTC: Inverter Stoppage Code;

FTC: Fan Controller Stoppage Code

(2) Deletion of Alarm Code History

Press PSW1 and PSW3 for 5 seconds to clear the alarm code history while the history data display. (All history can be deleted.)

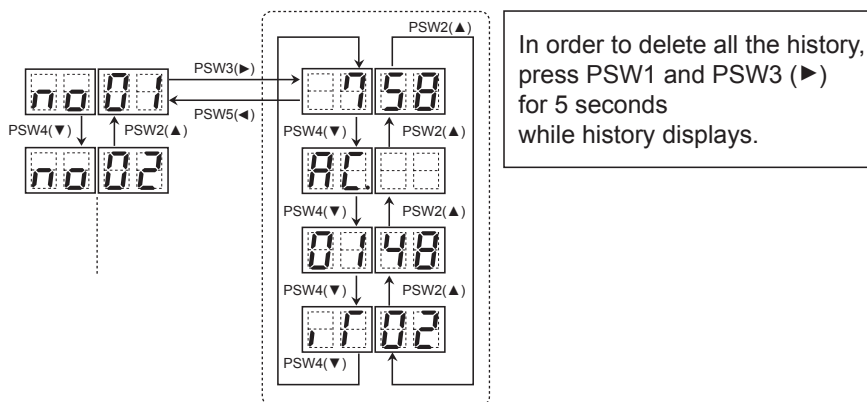

1.1.5 Emergency Operation

(1) Emergency Mode Operation from Remote Control Switch for Compressor Failure If one compressor is failed, emergency operation mode is available by the remote control switch after excluding the failed compressor. Even if the compressor is failed, the air conditioning operation is continuously available until the troubleshooting is performed.

- * In case of following alarm codes, emergency operation is available.
- * Inverter Compressor Failure
 - 06: Abnormality of inverter voltage
 - 23: Abnormality of discharge thermistor
 - 48: Activation of over current protection device
 - 51: Abnormality of inverter current sensor
 - 53: Inverter error signal detection
 - 54: Abnormality of inverter fin temperature

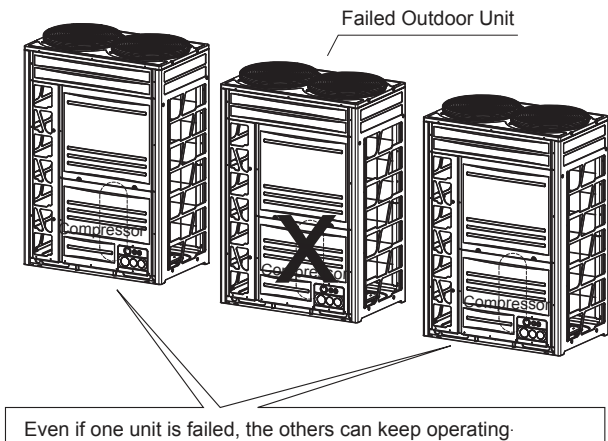

(a) Procedure

<In case of HYPE-J01H>

By pressing " " for 3 seconds simultaneously, emergency mode starts.
 "Emerg." can be displayed on the LCD during this operation.

(b) Operation Condition

This emergency operation is NOT applicable to all the compressors mounted in the failed outdoor unit.

<HYPE-J01H>

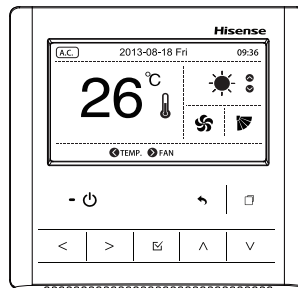

Press " " for 3 seconds.

Emergency Operation Indication

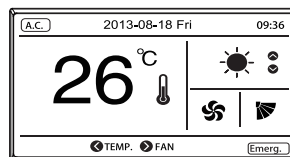

[Emerg.] displays on the LCD of the remote control switch and the emergency operation starts.

NOTE:

- Emergency operation is available only when all the indoor unit and remote control to be connected are for H-NET.
- Emergency operation is available only when the alarm codes above (*) display.
- The emergency operation is not available for the failures of inverter PCB or fan controller.
- This emergency operation is not a normal operation but a temporary one until the service people come. If the alarm displays again during the emergency operation, it cannot be canceled.
- Do not perform emergency operation for more than 8 hours. Otherwise, the unit may be damaged.

(2) Emergency Mode Operation from Outdoor Unit PCB for Compressor Failure

① For Combination of Outdoor Units

This operation is an emergency operation by excluding the failed unit when the inverter compressor fails.

<Alarms Corresponding to Inverter Compressor Failure>

- 06: Abnormality of inverter voltage
- 23: Abnormality of discharge thermistor
- 48: Activation of over current protection device
- 51: Abnormality of inverter current sensor
- 53: Inverter error signal detection
- 54: Abnormality of inverter fin temperature

<Procedure>

1. Turn OFF all the main switches of outdoor and indoor units.
2. Check the inverter PCB. If inverter PCB is faulty, disconnect the wiring (U, V, W) of diode module. (Insulate the disconnected terminals.)
3. Turn DSW5-No.1 and No.2 ON to stop the compressor operation. If they are set, all the set compressors in the failed outdoor unit will NOT operate. For heat pump system and cooling only system, fully close the stop valves (for gas/liq-uid) of the failed outdoor unit. Set control PCB of the failed outdoor unit.
4. Turn ON the power supply.
5. Start the operation by remote control switch.

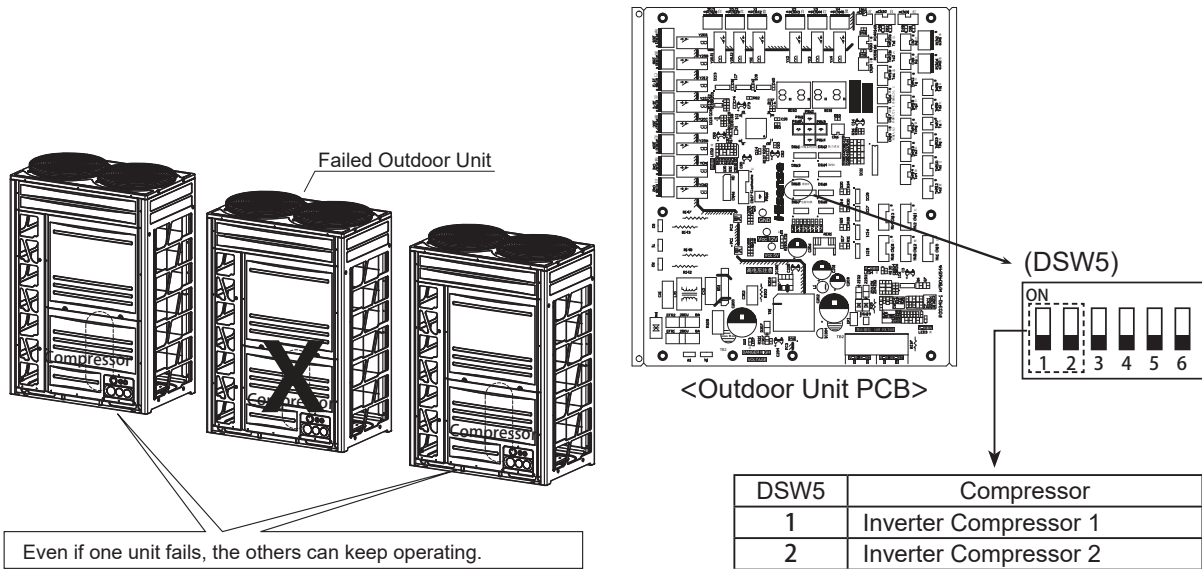

NOTE:

- Measure the insulation resistance of inverter compressor.
Do not perform the emergency operation when the insulation resistance is 0Ω.
The other compressors may be damaged because there is a possibility that refrigerant oil is oxidized.
- In this emergency operation, compressor frequency cannot be controlled normally.
Therefore, alarm code "07", "43", "44", "45" or "47" may display on LCD.
- This emergency operation may not provide sufficient cooling and heating capacity.
- This operation is an emergency but a temporary operation when the inverter compressor is damaged.
Therefore, replace it with the new one as soon as possible.
- Turn OFF DSW5-No.1, No.2 of outdoor unit PCB after replacing the compressor.
If this setting is not performed, the inverter compressor will be damaged.

② For Outdoor Unit without Combination

This operation is an emergency operation by excluding the failed inverter compressor.

<Alarms Corresponding to Inverter Compressor Failure>

- 06: Abnormality of inverter voltage
- 23: Abnormality of discharge thermistor
- 48: Activation of over current protection device
- 51: Abnormality of inverter current sensor
- 53: Inverter error signal detection
- 54: Abnormality of inverter fin temperature

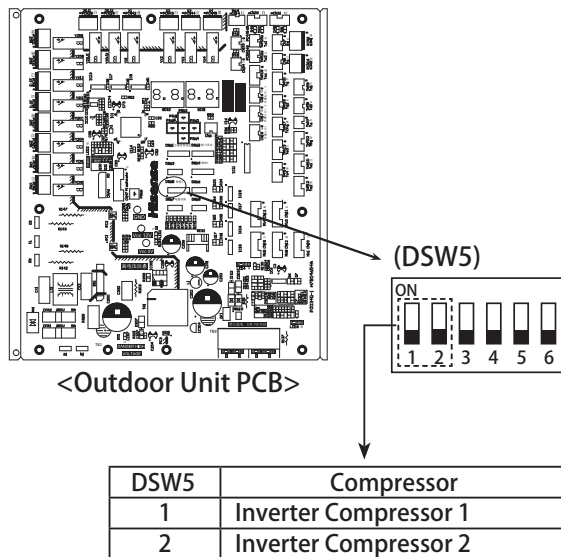

<Procedure>

1. Turn OFF all the main switches of outdoor and indoor units.
2. Check the inverter PCB. If inverter PCB is faulty, disconnect the wiring (U, V, W) of diode module. (Insulate the disconnected terminals.)
3. Turn DSW5-No.1 or DSW5-No.2 ON to stop the failed compressor operation. Not all the compressors in the outdoor unit will stop the operation. If two compressors stopped simultaneously, the stoppage cause is supposed to be d1-30.
4. Turn ON the power supply.
5. Start the operation by remote control switch.

NOTE:

- Measure the insulation resistance of inverter compressor.
Do not perform the emergency operation when the insulation resistance is 0Ω.
The other compressors may be damaged because there is a possibility that refrigerant oil is oxidized.
- In this emergency operation, compressor frequency cannot be controlled properly.
Therefore, alarm code "07", "43", "44", "45" or "47" may display on LCD.
- This emergency operation may not provide sufficient cooling and heating capacity.
- This operation is an emergency but a temporary operation when the inverter compressor is damaged.
Therefore, replace it with the new one as soon as possible.
- Turn OFF DSW5-No.1, No.2 of outdoor unit PCB after replacing the compressor.
If this setting is not performed, the inverter compressor will be damaged.

(3) Emergency Mode Operation from Outdoor Unit PCB for Fan Failure

① For Combination of Outdoor Units

This operation is an emergency operation by excluding the failed fan.

<Alarms Corresponding to Fan Failure>

- 04. :Abnormality transmitting between fan controller and outdoor unit PCB
- 06. : Abnormality of fan controller voltage
- 57 : Activation of fan controller protection device
- 5A: Abnormality of fan controller fin temperature
- 5b : Activation of over current protection
- 5C : Abnormality of fan controller sensor

<Procedure>

1. Turn OFF all the main switches of outdoor and indoor units.
2. Check the inverter PCB. If inverter PCB is faulty, disconnect the wiring PCN2(U, V, W) of diode module. (Insulate the disconnected terminals.)
3. Turn DSW2-No.5 or No.6 ON to stop the fan operation.
 For double fan unit, if only one of them is set, the corresponding fan will NOT operate. If both of them are set, turn DSW5-No.1 and No.2 ON at the same time, then the failed outdoor unit will NOT operate.
 For single fan unit, so long as DSW2-No.5 is set, turn DSW5-No.1 and No.2 ON of the same unit at the same time, then the failed outdoor unit will NOT operate.
 For heat pump system and cooling only system, fully close the stop valves (for gas/liquid) if all fans of the unit are failed.
4. Turn ON the power supply.
5. Start operation by remote control switch.

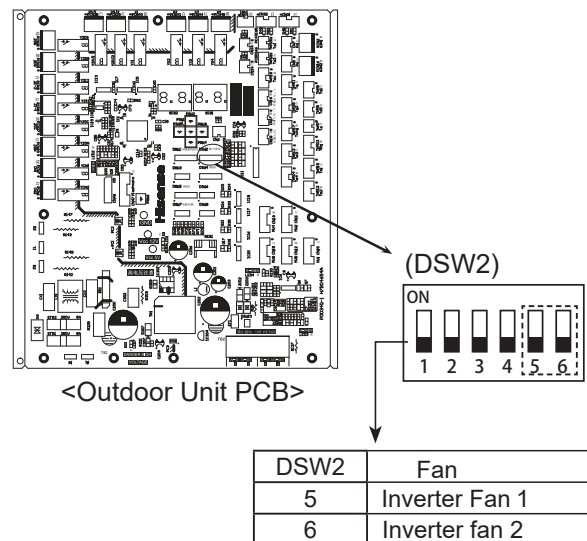
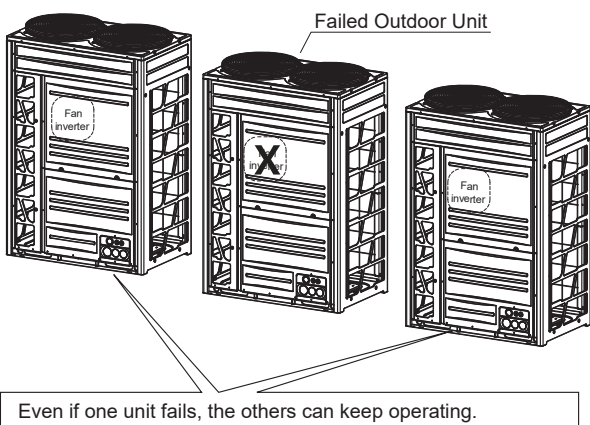

NOTE:

- In this emergency operation, fan frequency cannot be controlled properly. Therefore, alarm code "07", "43", "44", "45" or "47" may display on LCD.
- This emergency operation may not provide sufficient cooling and heating capacity.
- This operation is an emergent but temporary operation when the inverter fan is damaged. Therefore, replace it with the new one as soon as possible.
- Turn OFF DSW2-No.5, No.6 of outdoor unit PCB after replacing the failed fan. If this setting is not performed, the inverter fan will be damaged.

! WARNING

Turn ON DSW5-No.1, No.2 when all fans are failed for any unit, otherwise, the unit will be damaged.

② For Outdoor Unit without Combination

This operation is an emergency operation by excluding the failed inverter fan.

<Alarms Corresponding to Inverter Compressor Failure>

- 04. : Abnormality transmitting between fan controller and outdoor unit PCB
- 06. : Abnormality of fan controller voltage
- 56 : Abnormality in fan motor location detection
- 57 : Activation of fan controller protection device
- 58 : Abnormality of fan controller
- 5A : Abnormality of fan controller fin temperature
- 5B : Activation of over current protection
- 5C : Abnormality of fan controller sensor

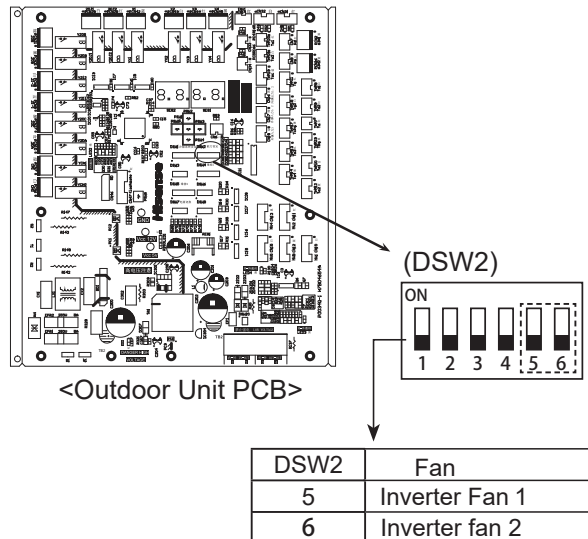

<Procedure>

1. Turn OFF all the main switches of outdoor and indoor units.
2. Check the inverter PCB. If inverter PCB is faulty, disconnect the wiring PCN2(U, V, W) of diode module. (Insulate the disconnected terminals.)
3. Turn DSW2-No.5 or No.6 ON to stop the fan operation.
For double fan unit, if only one of them is set, the corresponding fan will NOT operate. If both of them are set, the outdoor unit will NOT operate, the stoppage cause is supposed to be d1-30. For single fan unit, so long as DSW2-No.5 is set, the outdoor unit will NOT operate, the stoppage cause is supposed to be d1-30.
4. Turn ON the power supply.
5. Start the operation by remote control switch.

NOTE:

- In this emergency operation, fan frequency cannot be controlled properly. Therefore, alarm code "07", "43", "44", "45" or "47" may display on LCD.
- This emergency operation may not provide sufficient cooling and heating capacity.
- This operation is an emergency but a temporary operation when the inverter fan is damaged. Therefore, replace it with the new one as soon as possible.
- Turn OFF DSW2-No.5, No.6 of outdoor unit PCB after replacing the failed fan. If this setting is not performed, the inverter fan will be damaged.

1.1.6 One-Key Refrigerant Recovery

1.1.6.1 One-key Refrigerant Recovery to Replace Indoor Unit

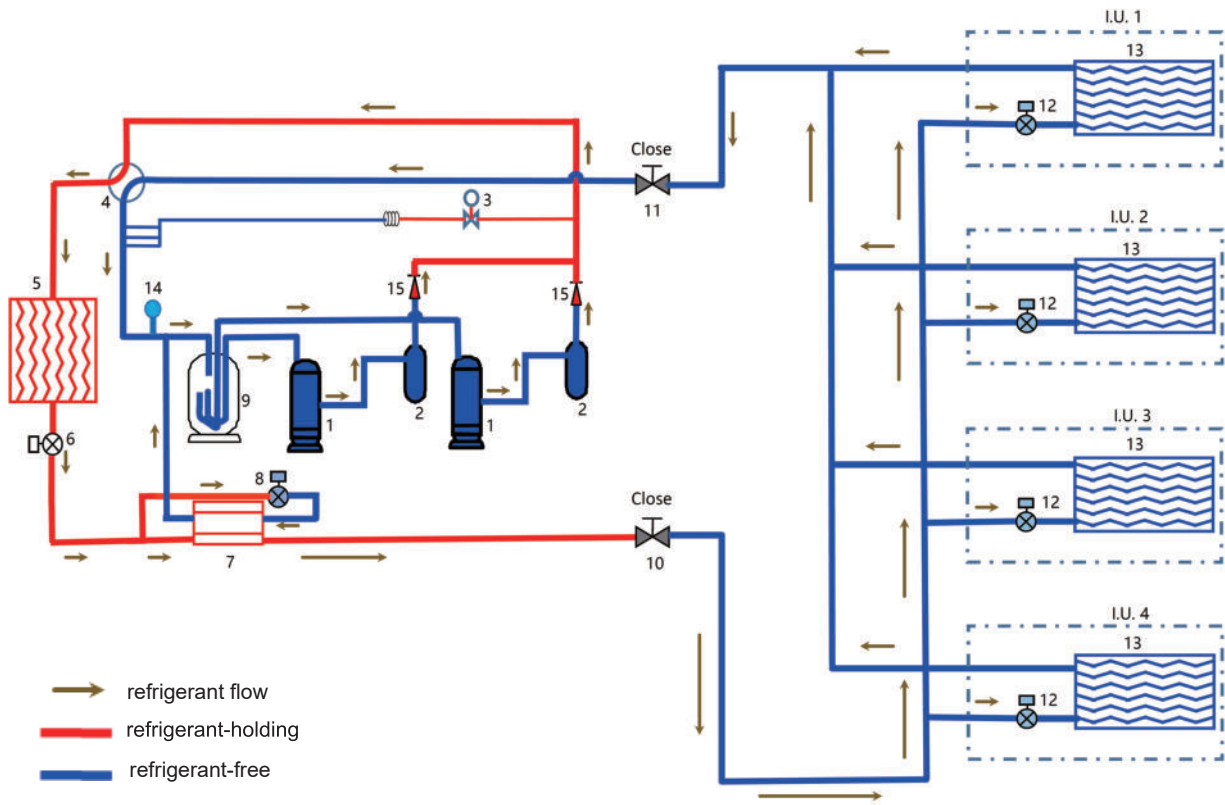

NO.	Name	NO.	Name
1	Compressor	9	Accumulator
2	Oil separator	10	Stop valve (liquid)
3	Solenoid valve (SVA)	11	Stop valve (gas)
4	4-way reversing valve	12	Expansion valve (EVI)
5	Heat exchanger	13	Heat exchanger
6	Expansion valve(EVO)	14	Pressure sensor(Ps)
7	Subcooler	15	Check valve
8	Expansion valve(EVB)		

Take single-unit with double-compressor as an example, and the indoor units are to be replaced.

- ① When performing one-key refrigerant recovery, the unit works in cooling mode.
- ② The above diagram shows the distribution of refrigerant-holding and refrigerant-free area when one-key refrigerant recovery is completed, from which we can tell that in this case the final refrigerant-holding area is between the check valve (15) and liquid side stop valve (10), while the refrigerant-free area is at indoor unit and outdoor low pressure side.

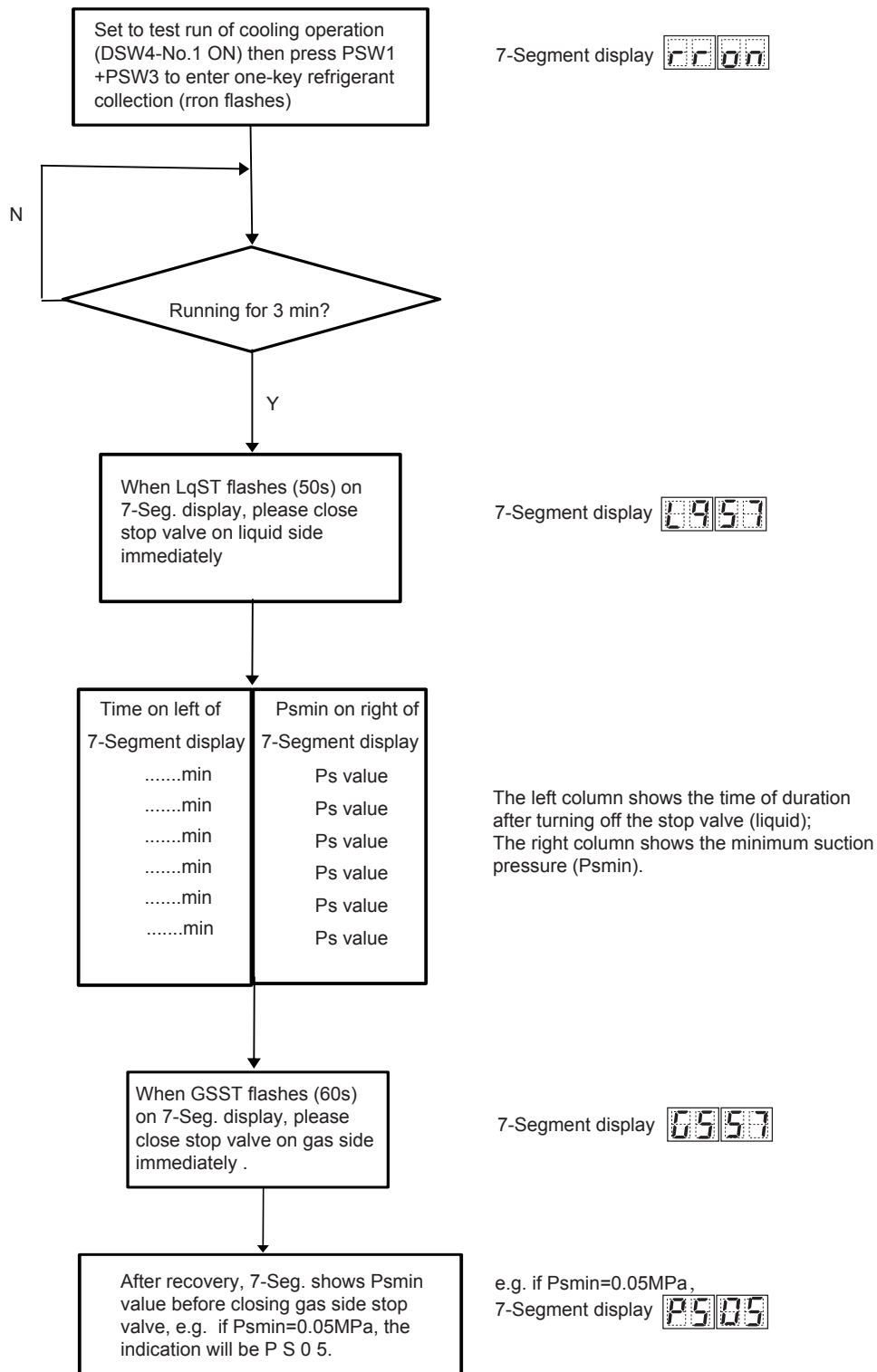

NOTE:

- One-key refrigerant recovery starts.
- Prompt to turn off stop valve on liquid side at once.
- Prompt to turn off stop valve on gas side at once.
- During refrigerant recovery, the 7-segment display shows time (minute) on the left side and pressure at right side (only value following decimal point will display, e.g. 15 represents 0.15MPa). Where pressure is greater than 1MPa, 99 will display, and 00 when less than 0MPa.
- System parameters can be checked during one-key refrigerant recovery.

<Procedure>

When one-key refrigerant recovery to be performed to replace indoor unit, the operation procedure is as below:

- (1) Please prepare hexagon wrench to close gas side and liquid side stop valves.
- (2) Power on outdoor unit and set to cooling test run (DSW4-No.1 ON) , then press PSW1+PSW3 to enter one-key refrigerant recovery.
- (3) When LqST flashes on 7-segment display, please close liquid side stop valve immediately.
- (4) When LqST does not flash, 7-segment display shows the time of duration and minimum suction pressure of the system after closing the stop valve.
- (5) When GSST flashes on 7-segment display, please close gas side stop valve immediately.
- (6) After completion of recovery, 7-segment shows P_{min} value before closing the stop valve on gas side.
- (7) Set DSW4-No.1 at OFF after recovery and cut off power supply to indoor units and outdoor units.

WARNING

When one-key refrigerant recovery to be performed to replace indoor unit, please pay attention to the following items:

- (1) Each model of unit has its maximum refrigerant recovery quantity as shown in below table. Once exceeds 130% of the value in the table, one-key refrigerant recovery is not recommended.

Capacity (kBtu/h)	Max. Refrigerant (kg)
76-114	8
136-154	10
170	15
190-232	17
250-272	19

- (2) Amount of collected refrigerant relevant to outdoor temperature. When the outdoor temperature is above 40°C, it is suggested not to perform one-key refrigerant recovery.
- (3) During one-key refrigerant recovery, set dip switch to DSW4-No.1 OFF to exit from operation.
- (4) After recovery, please determine if it is thoroughly collected based on the pressure displayed on 7-segment display. If not, use refrigerant recovery machine to collect the remaining refrigerant.
- (5) After recovery and the replacement of indoor unit, please check refrigerant quantity by referring to 3.4 Calculation of Additional Refrigerant in Design Chapter.
- (6) After recovery, it is a must to set DSW4-No.1 at OFF and cut off power supply to outdoor and indoor units. If not, the units do not start up.
- (7) After refrigerant recovery, please replace indoor unit as soon as possible. It is strictly forbidden to leave the units to high temperature outdoor area for a long term, in case of rapid ramping of refrigerant pressure inside heat exchanger of outdoor unit, which may lead to potential safety hazard.
- (8) For units to which check valve leakage incurred, it is not recommended to perform refrigerant recovery.

1.1.6.2 One-key Refrigerant Recovery to Replace Compressor for Single Unit

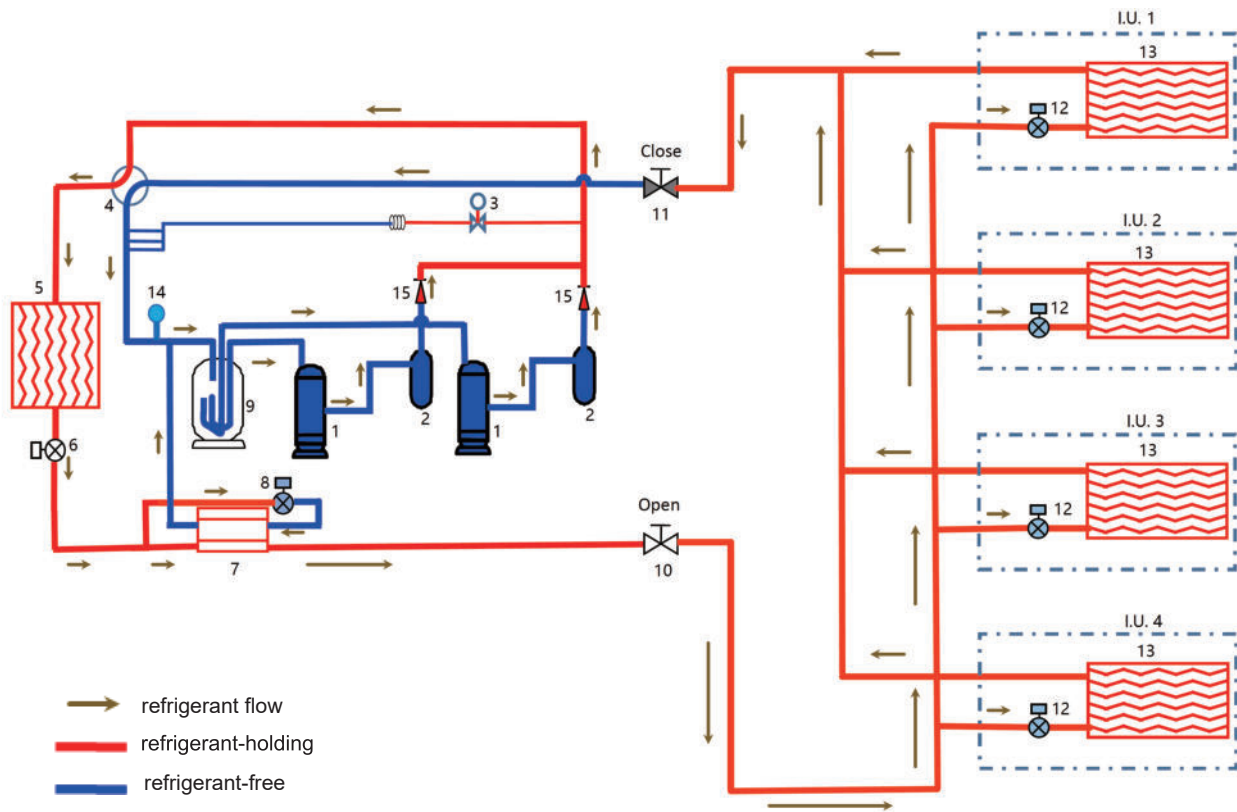

NO.	Name	NO.	Name
1	Compressor	9	Accumulator
2	Oil separator	10	Stop valve (liquid)
3	Solenoid valve (SVA)	11	Stop valve (gas)
4	4-way reversing valve	12	Expansion valve (EVI)
5	Heat exchanger	13	Heat exchanger
6	Expansion valve(EVO)	14	Pressure sensor(Ps)
7	Subcooler	15	Check valve
8	Expansion valve(EVB)		

Take single-unit with double-compressor as an example, and a compressor is to be replaced.

- ① When performing one-key refrigerant recovery, the unit works in cooling mode.
- ② The above diagram shows the distribution of refrigerant-holding and refrigerant-free area when one-key refrigerant recovery is completed, from which we can tell that in this case the final refrigerant-holding area is between the check valve (15) and gas side stop valve (11), while the refrigerant-free area is at outdoor low pressure side.

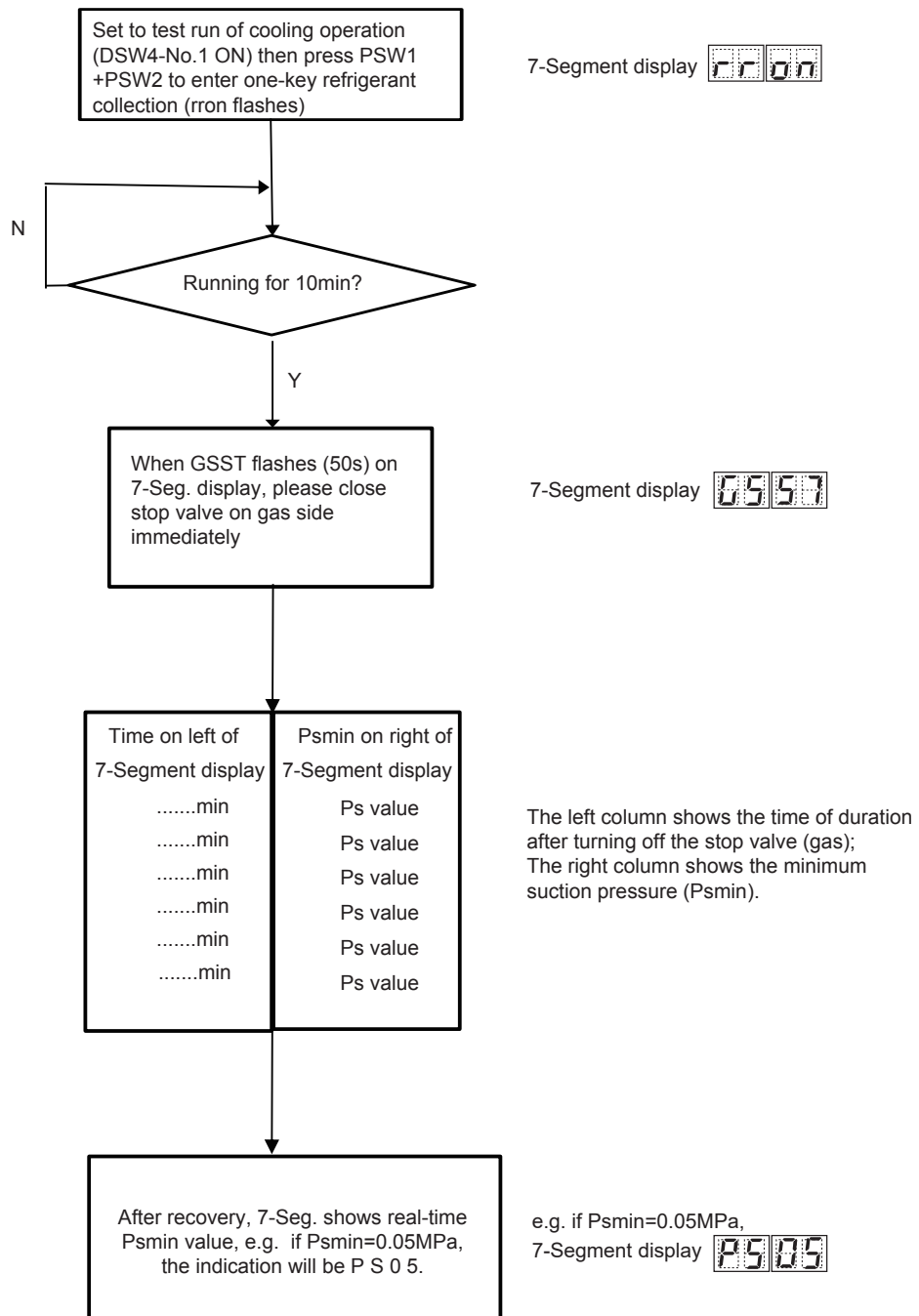

<Procedure>

For basic unit, when one-key refrigerant recovery to be performed to replace compressor, the operation procedure is shown as below and the operation is applicable to dual-compressor units only:

- (1) Please prepare a hexagon wrench to close gas side stop valve.
- (2) Please refer to 1.1.5 (2) ② For Outdoor Unit without Combination to exclude the failed compressor.
- (3) Power on outdoor unit and set to cooling test run (DSW4-No.1 ON) , then press PSW1+PSW2 to enter one-key refrigerant recovery.
- (4) When GSST flashes on 7-segment display, please close gas side stop valve immediately.
- (5) When GSST does not flash, 7-segment display shows the time of duration and minimum suction pressure of the system after closing the stop valve.
- (6) After completion of recovery, 7-segment display shows the real-time suction pressure of the system.
- (7) Please set DSW4-No.1 and DSW5-No.1 at OFF or DSW5-No.2 at OFF after recovery, and cut off power supply to indoor units and outdoor units.

WARNING

For basic unit, when one-key refrigerant recovery to be performed to replace compressor, please pay attention to the following items:

- (1) During one-key refrigerant recovery, set dip switch to DSW4-No.1 OFF to exit from operation.
- (2) After recovery, please determine if it is thoroughly collected based on the pressure indicated on 7-segment display. If not, use refrigerant recovery machine to collect the remaining refrigerant.
- (3) After recovery and the replacement of compressor, please check refrigerant quantity by referring to 3.4 Calculation of Additional Refrigerant in Design Chapter.
- (4) After recovery, it is a must to set DSW4-No.1 and DSW5-No.1 at OFF or DSW5-No.2 at OFF, and cut off power supply to indoor units and outdoor units. If not, the units do not start up.
- (5) For units to which check valve leakage incurred, it is not recommended to perform refrigerant recovery.

1.1.6.3 One-key Refrigerant Recovery to Replace Compressor of Combined Units

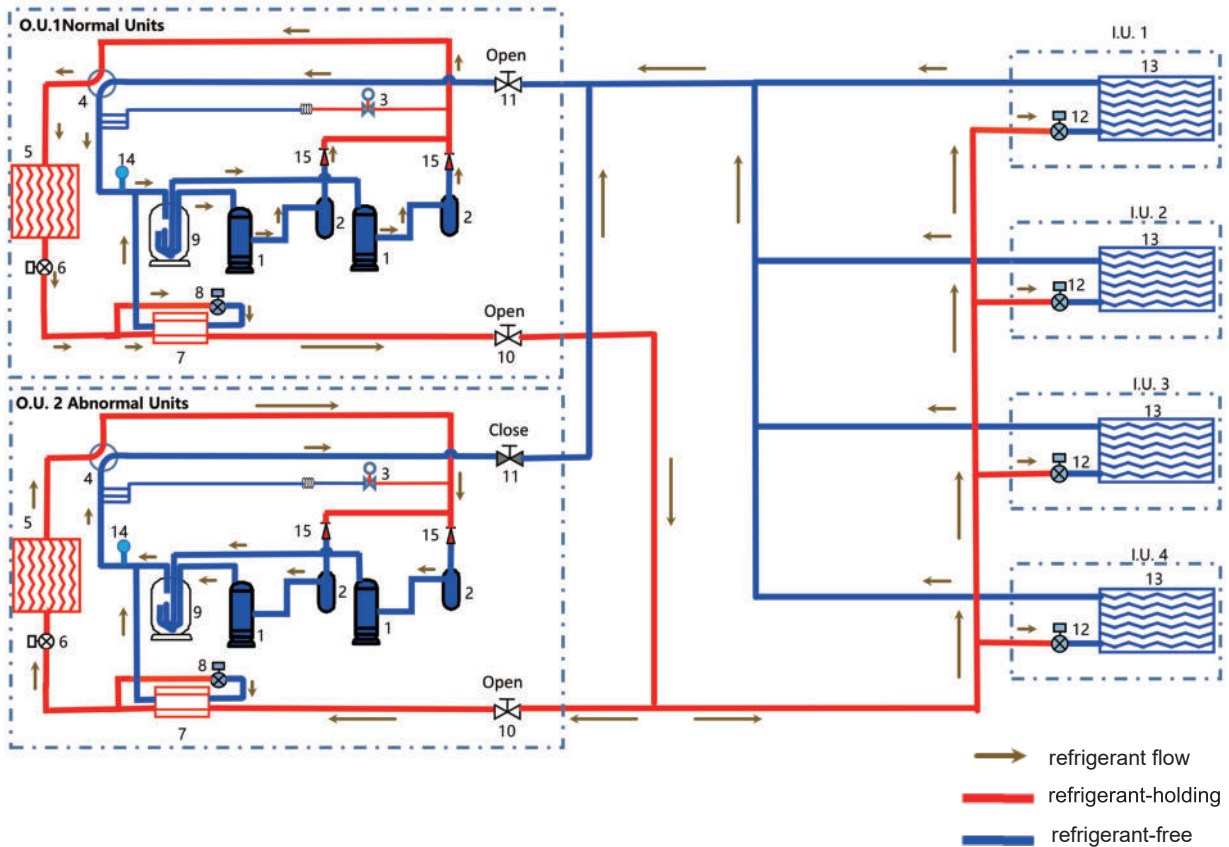

NO.	Name	NO.	Name
1	Compressor	9	Accumulator
2	Oil separator	10	Stop valve (liquid)
3	Solenoid valve (SVA)	11	Stop valve (gas)
4	4-way reversing valve	12	Expansion valve (EVI)
5	Heat exchanger	13	Heat exchanger
6	Expansion valve(EVO)	14	Pressure sensor(Ps)
7	Subcooler	15	Check valve
8	Expansion valve(EVB)		

Take double-unit module as an example, and a compressor is to be replaced.

- ① When performing one-key refrigerant recovery, the units run in cooling mode.
- ② The above diagram shows the distribution of refrigerant-holding and refrigerant-free area when one-key refrigerant recovery is completed, from which we can tell that in this case the final refrigerant-holding area is between the check valve (15) and EVI (12) at indoor side, while the refrigerant-free area is at indoor heat exchanger and outdoor low pressure side.

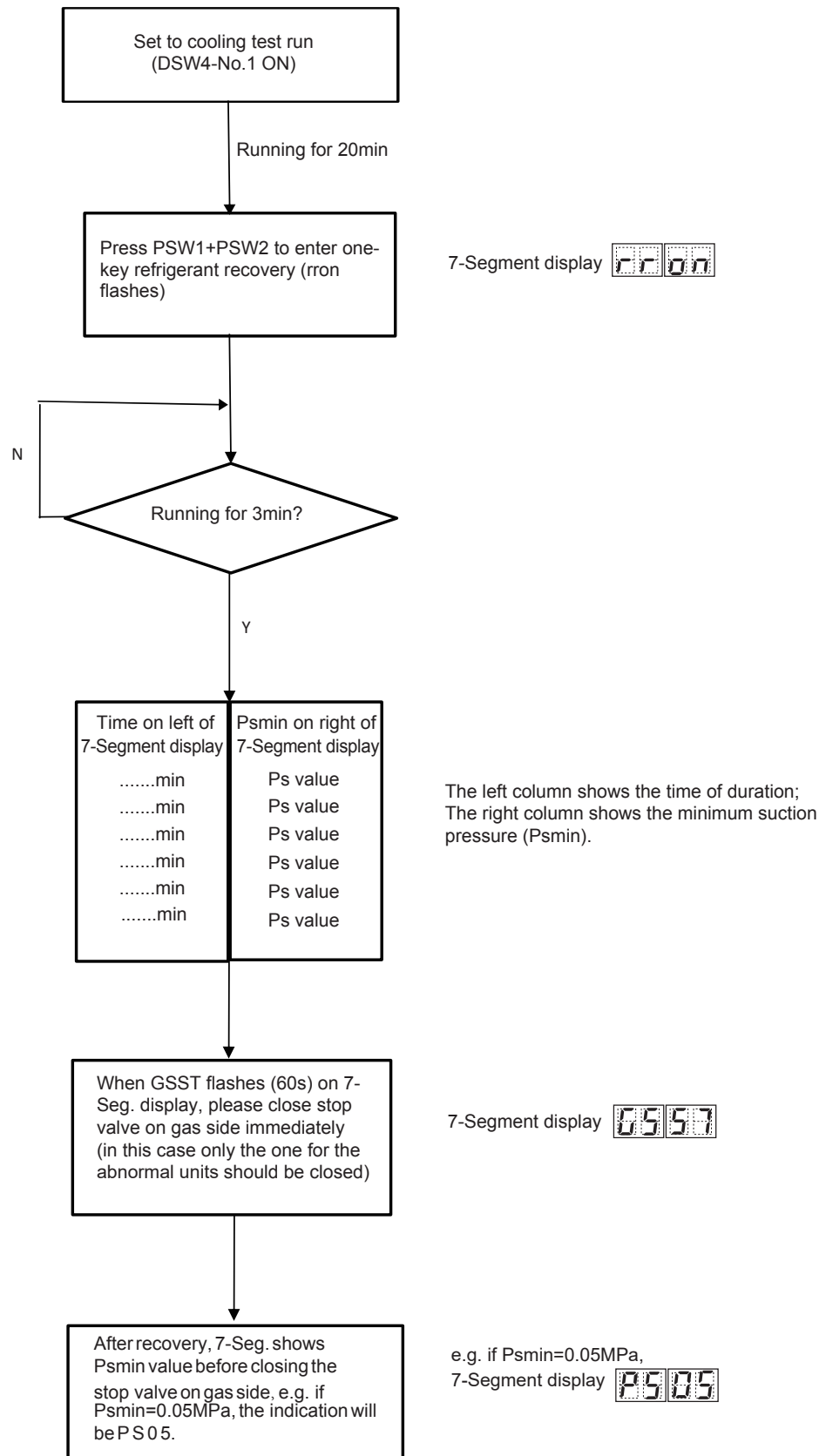

<Procedure>

For combination of units, when one-key refrigerant recovery to be performed to replace compressors, the operation procedure is as below:

- (1) Please prepare hexagon wrench to close gas side stop valve.
- (2) Please refer to 1.1.5 (2) ① For Combination of Outdoor Units to exclude the failed compressor.
- (3) Power on outdoor unit and set to cooling test run (DSW4-No.1 ON) , run for 20min then press PSW1 +PSW2 to enter one-key refrigerant recovery.
- (4) After running for 3min, 7-segment display shows the time of duration and minimum suction pressure of the system after closing the stop valve.
- (5) When GSST flashes on 7-segment display, please close gas side stop valve immediately. In this case only the one for the abnormal units should be closed.
- (6) After completion of recovery, 7-segment shows P_{min} value before closing the stop valve on gas side.
- (7) Please set DSW4-No.1 and DSW5-No.1 at OFF or DSW5-No.2 at OFF after recovery, and cut off power supply to indoor units and outdoor units.

 **WARNING**

For combination of units, when one-key refrigerant recovery to be performed to replace compressors, please pay attentions to the following items:

- (1) Amount of collected refrigerant relevant to outdoor temperature. When the outdoor temperature is above 40°C, it is suggested not to perform one-key refrigerant recovery.
- (2) During one-key refrigerant recovery, set dip switch to DSW4-No.1 OFF to exit from operation.
- (3) After recovery, please determine if it is thoroughly collected based on the pressure indicated on 7- segment display. If not, use refrigerant recovery machine to collect the remaining refrigerant.
- (4) After recovery and the replacement of compressor, please check refrigerant quantity by referring to 3.4 Calculation of Additional Refrigerant in Design Chapter.
- (5) After recovery, it is a must to set DSW4-No.1 and DSW5-No.1 at OFF or DSW5-No.2 at OFF, and cut off power supply to indoor units and outdoor units. If not, the units do not start up.
- (6) After refrigerant recovery, please replace compressor as soon as possible. It is strictly forbidden to leave the units to high temperature outdoor area for a long term, in case of rapid ramping of refrigerant pressure inside heat exchanger of outdoor unit, which may lead to potential safety hazard.
- (7) For units to which check valve leakage incurred, it is not recommended to perform refrigerant recovery.
- (8) If two or more outdoor units have damaged compressors, it is not recommended to perform one-key refrigerant recovery.

1.1.7 Failure of Power Supply to Indoor Unit and Remote Control Switch

- Lights and LCD are not Indicated.
- Not Operated

If fuses are melted or a breaker is activated, investigate the cause of over current and take necessary actions.

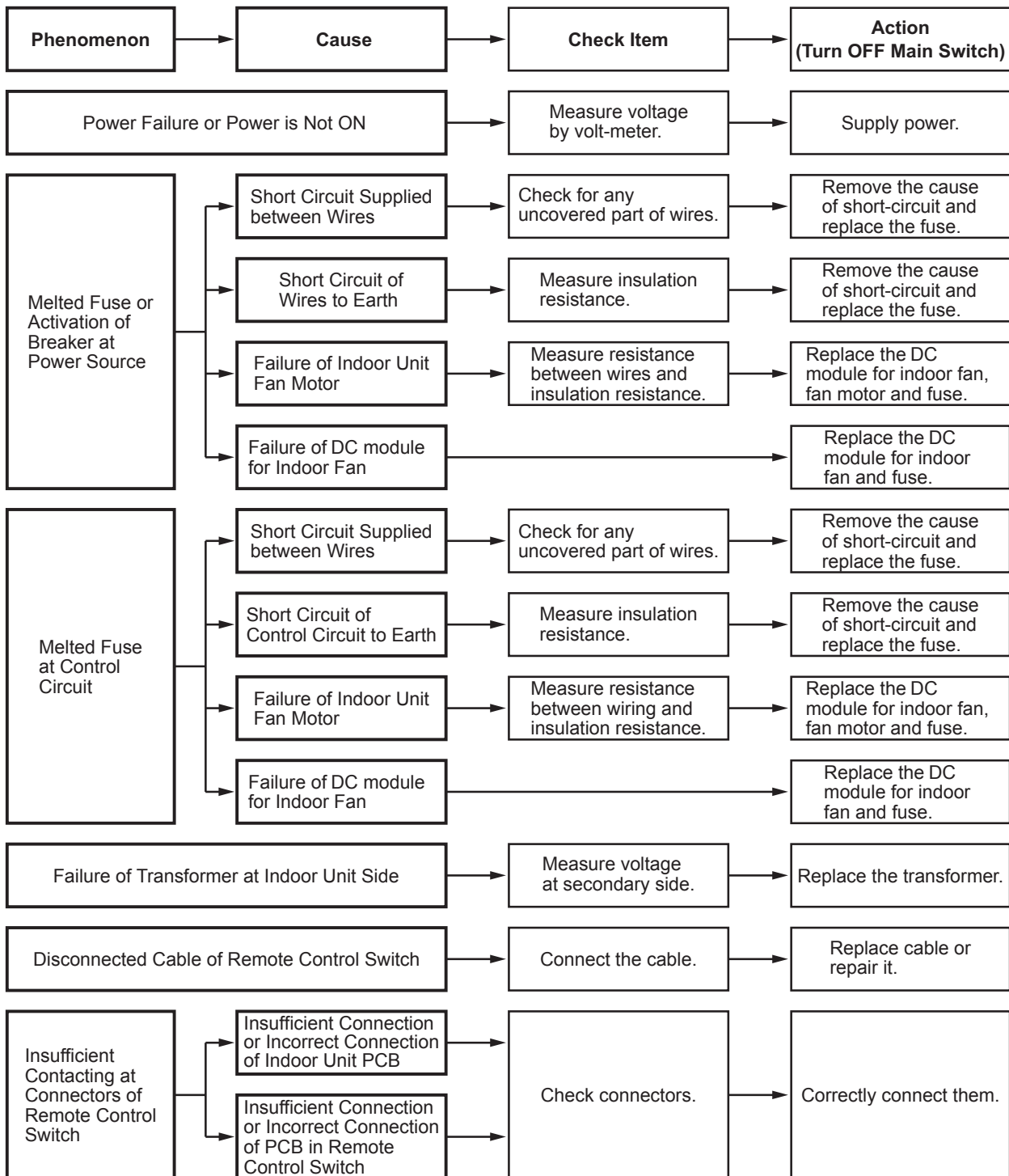

(1.1.7 Failure of Power Supply to Indoor Unit and Remote Control Switch)

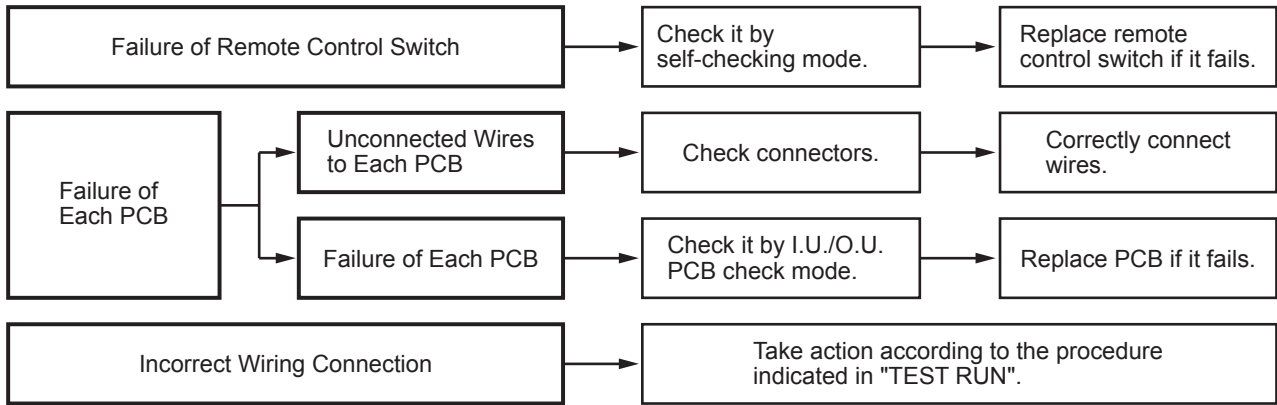

1.1.8 Abnormal Transmission between Remote Control Switch and Indoor Unit

- “RUN” Lamp on Remote Control Switch:
Flashing every 2 seconds

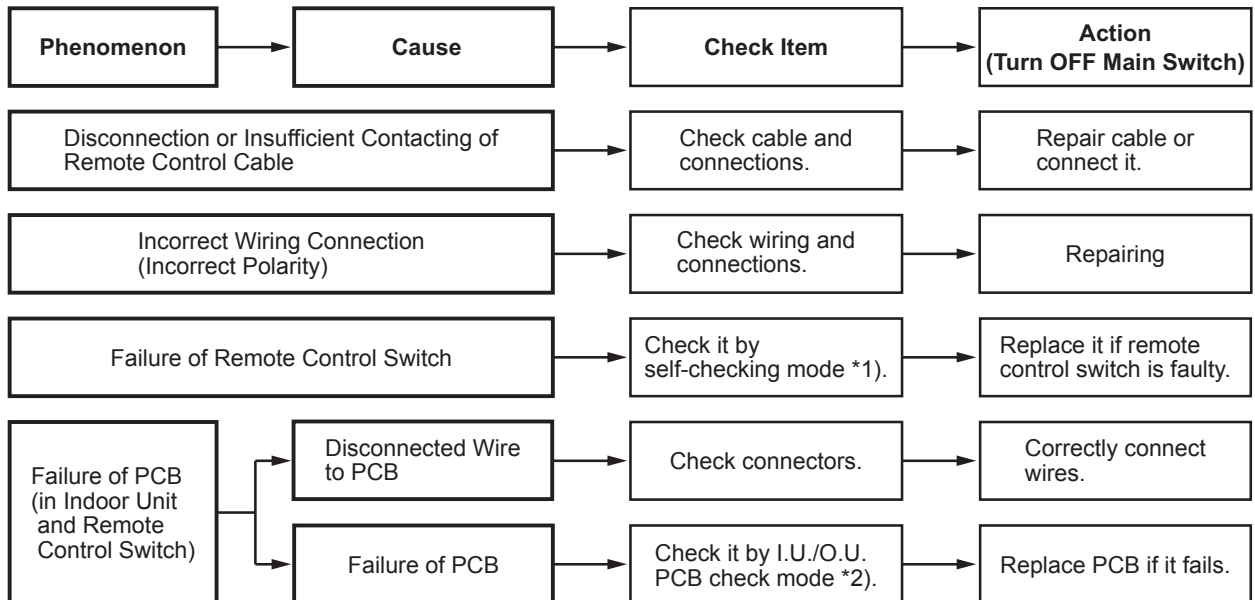

1.1.9 Abnormalities of Devices

In the case that no abnormality (Alarm Code) is indicated on the remote control switch, and normal operation is not available, take necessary actions according to the procedures mentioned below.

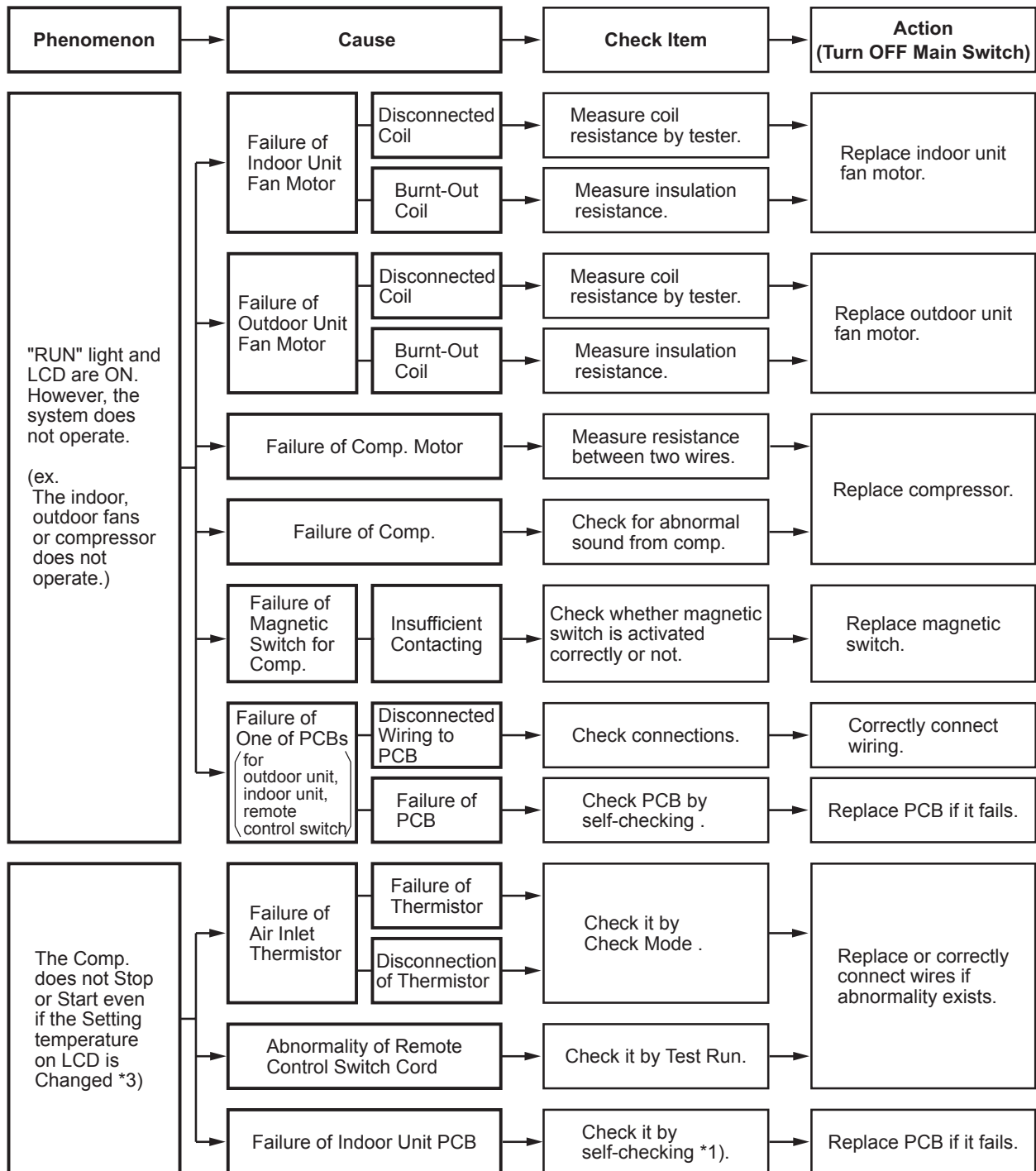

(1.1.9 Abnormalities of Devices)

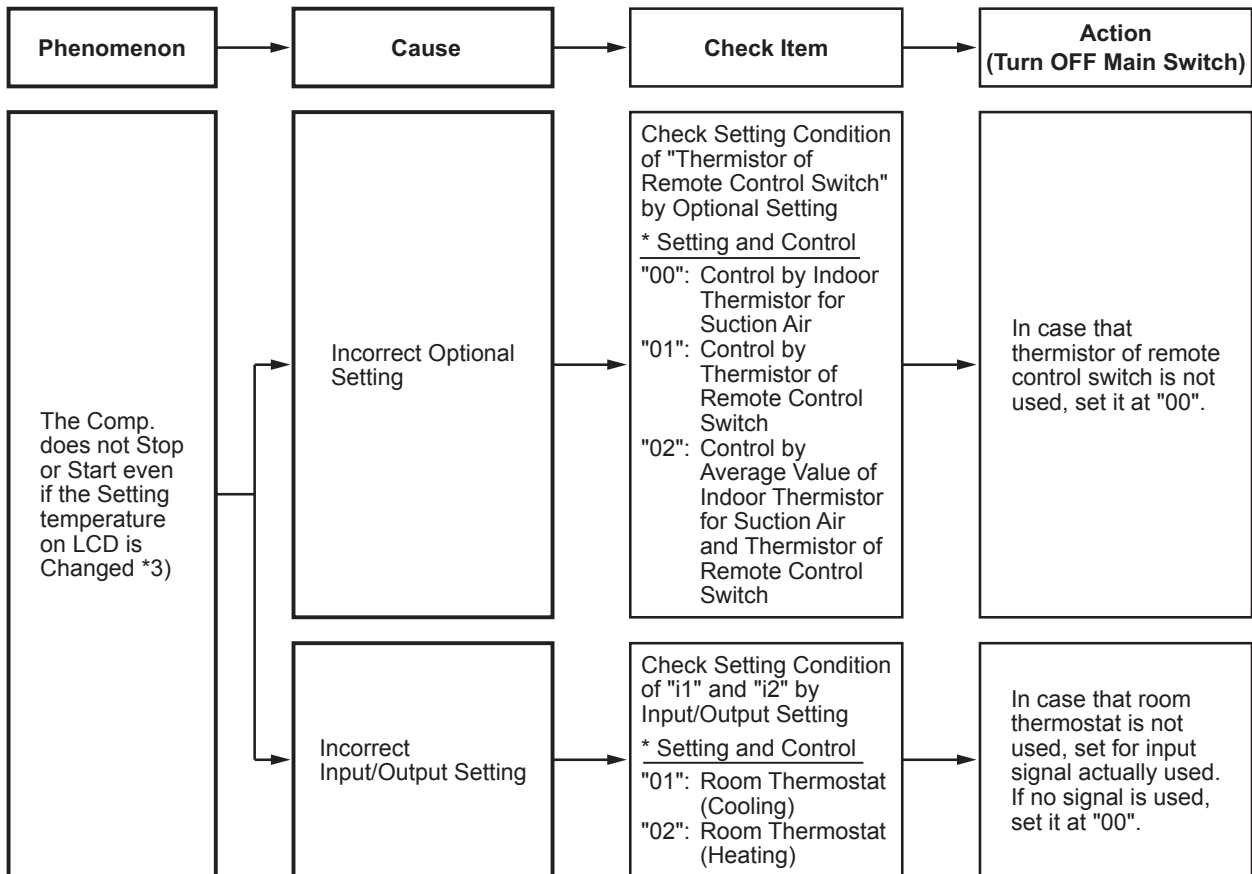

*3): Even if controllers are normal, the compressor does not operate under the following conditions.

- * Indoor Air Temp. or Outdoor Air Temp. is out of the operating temperature range.
- * When a cooling operation signal is given to the outdoor unit and a different operation signal is given to indoor units.
- * When demand signal or emergency stop signal is given to outdoor unit.

(1.1.9 Abnormalities of Devices)

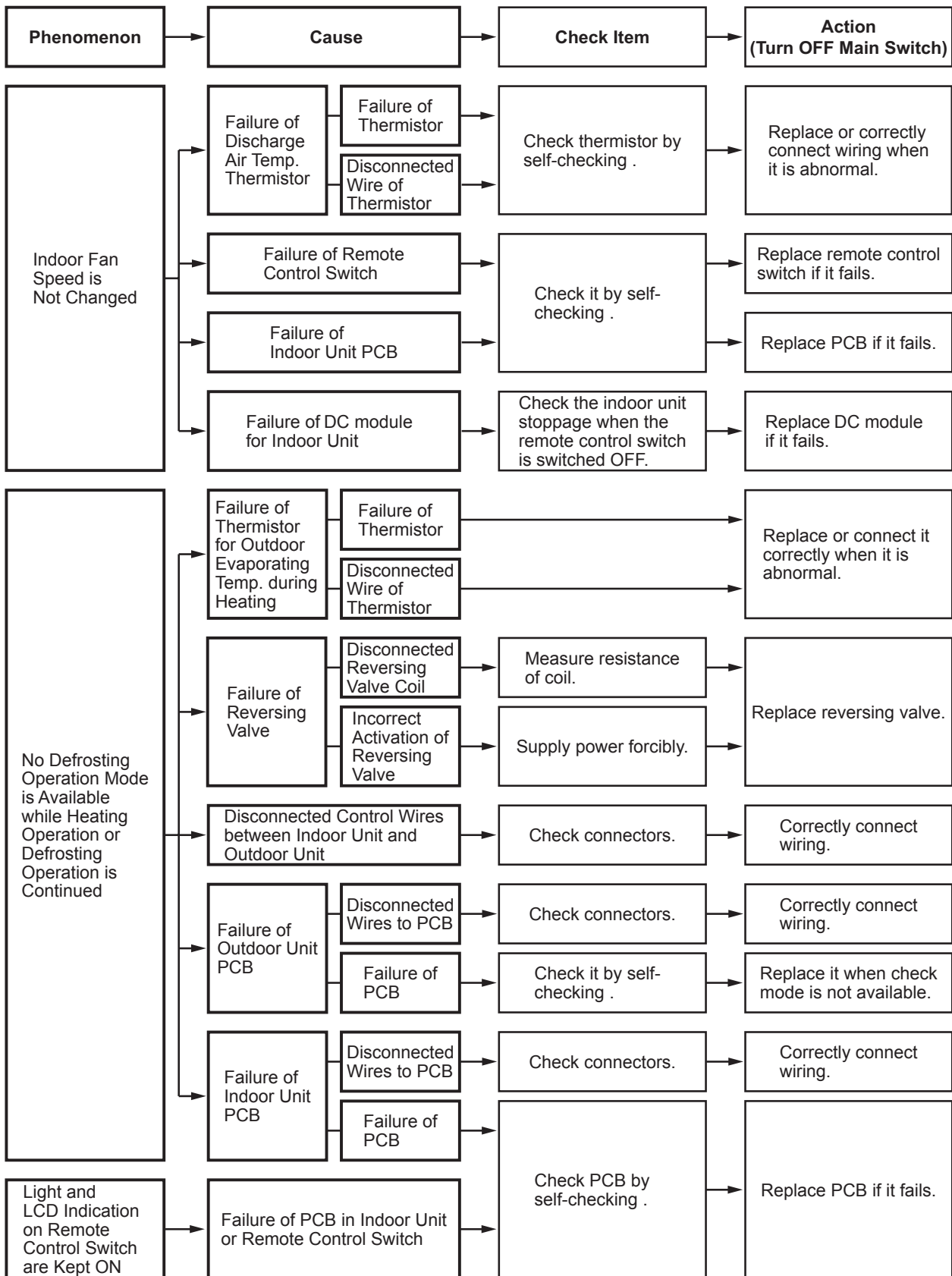

(1.1.9 Abnormalities of Devices)

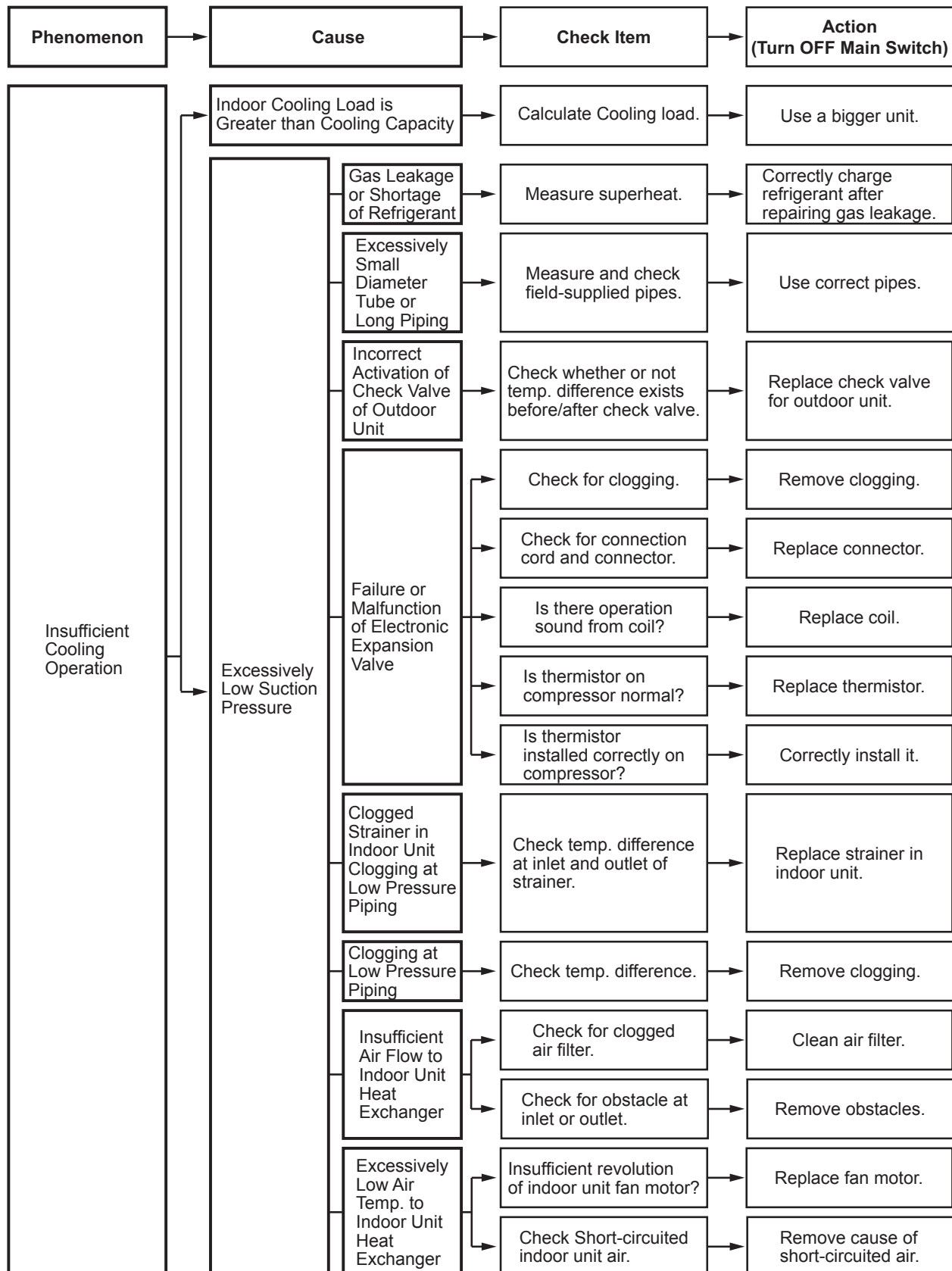

(1.1.9 Abnormalities of Devices)

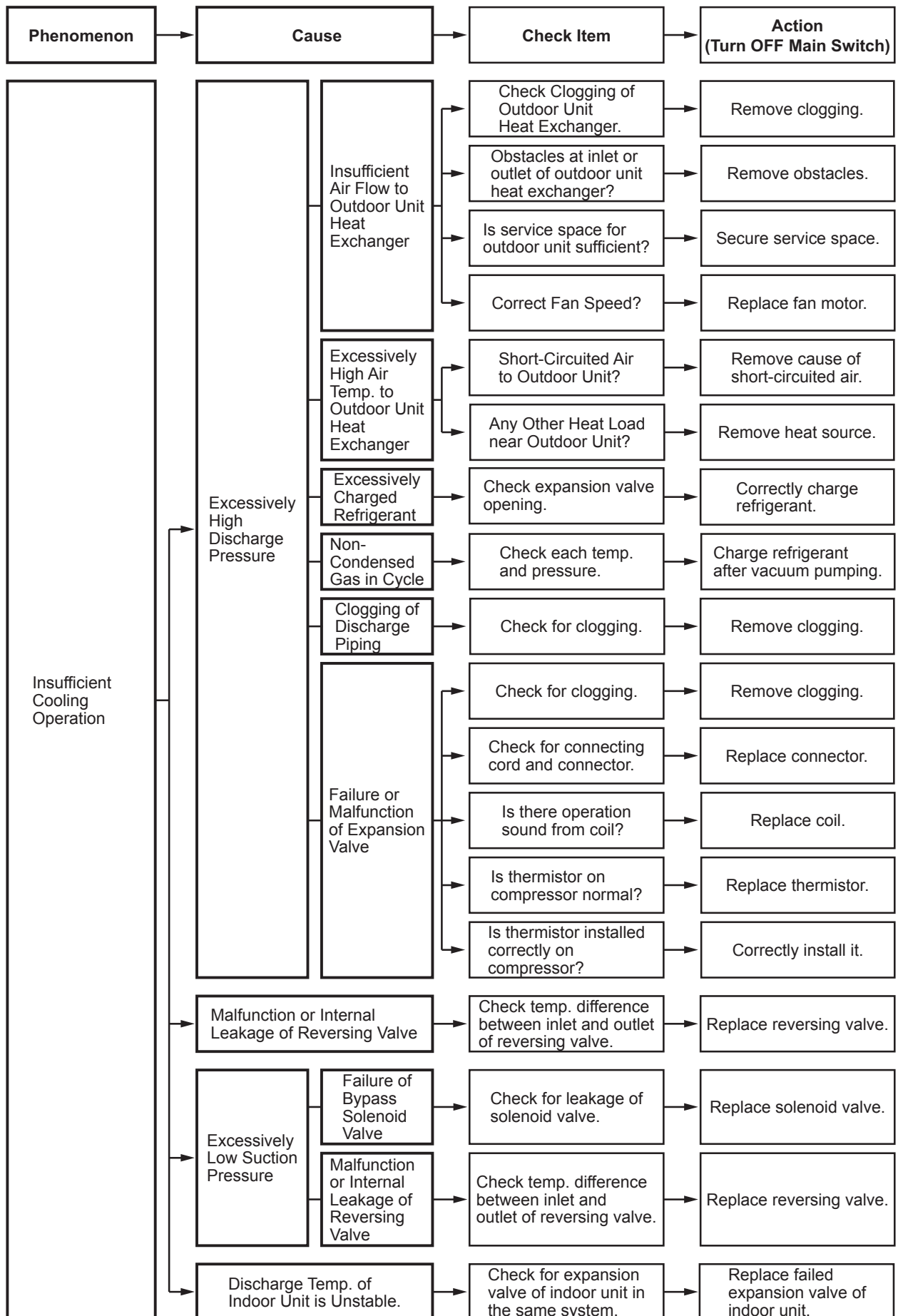

(1.1.9 Abnormalities of Devices)

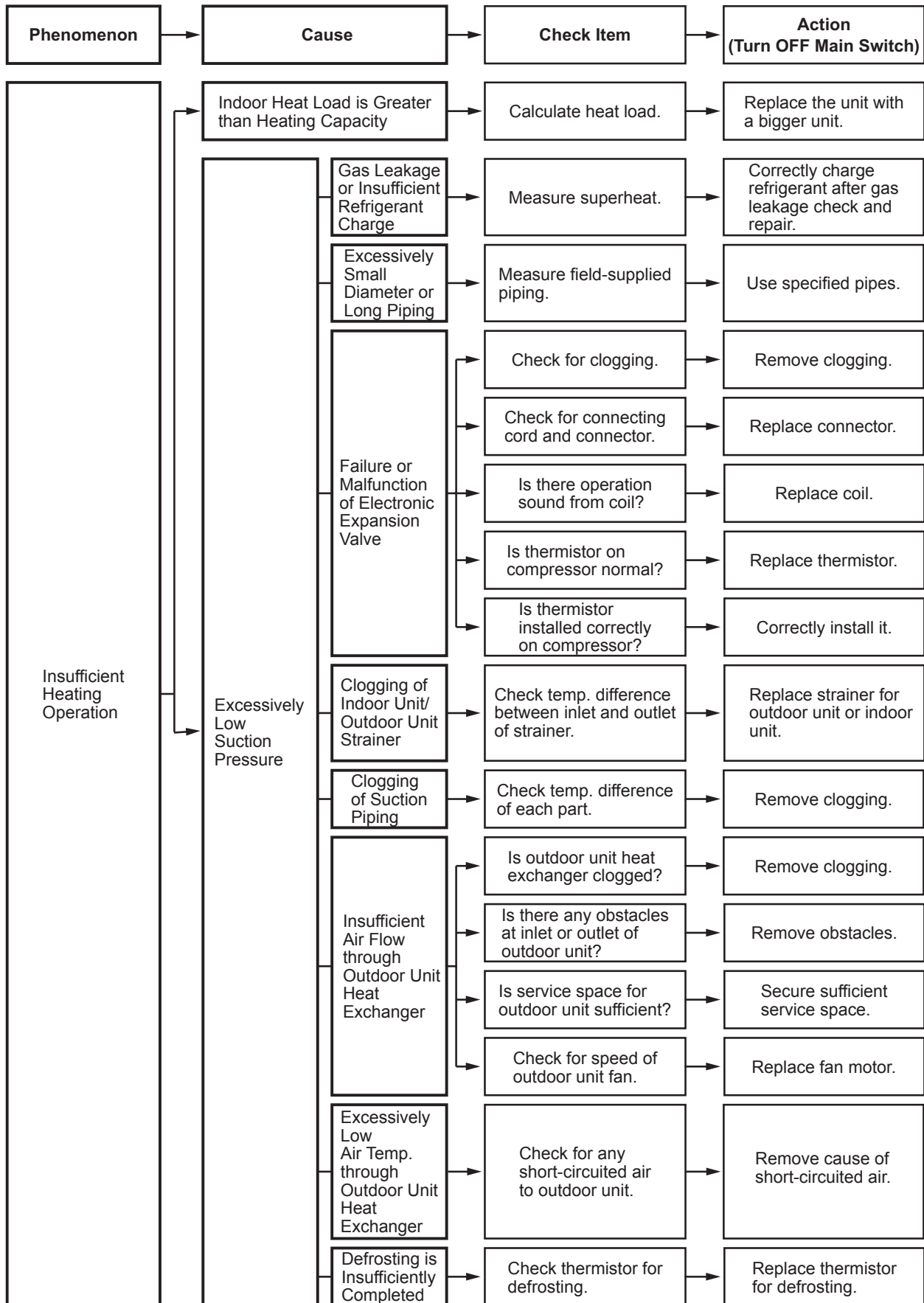

(1.1.9 Abnormalities of Devices)

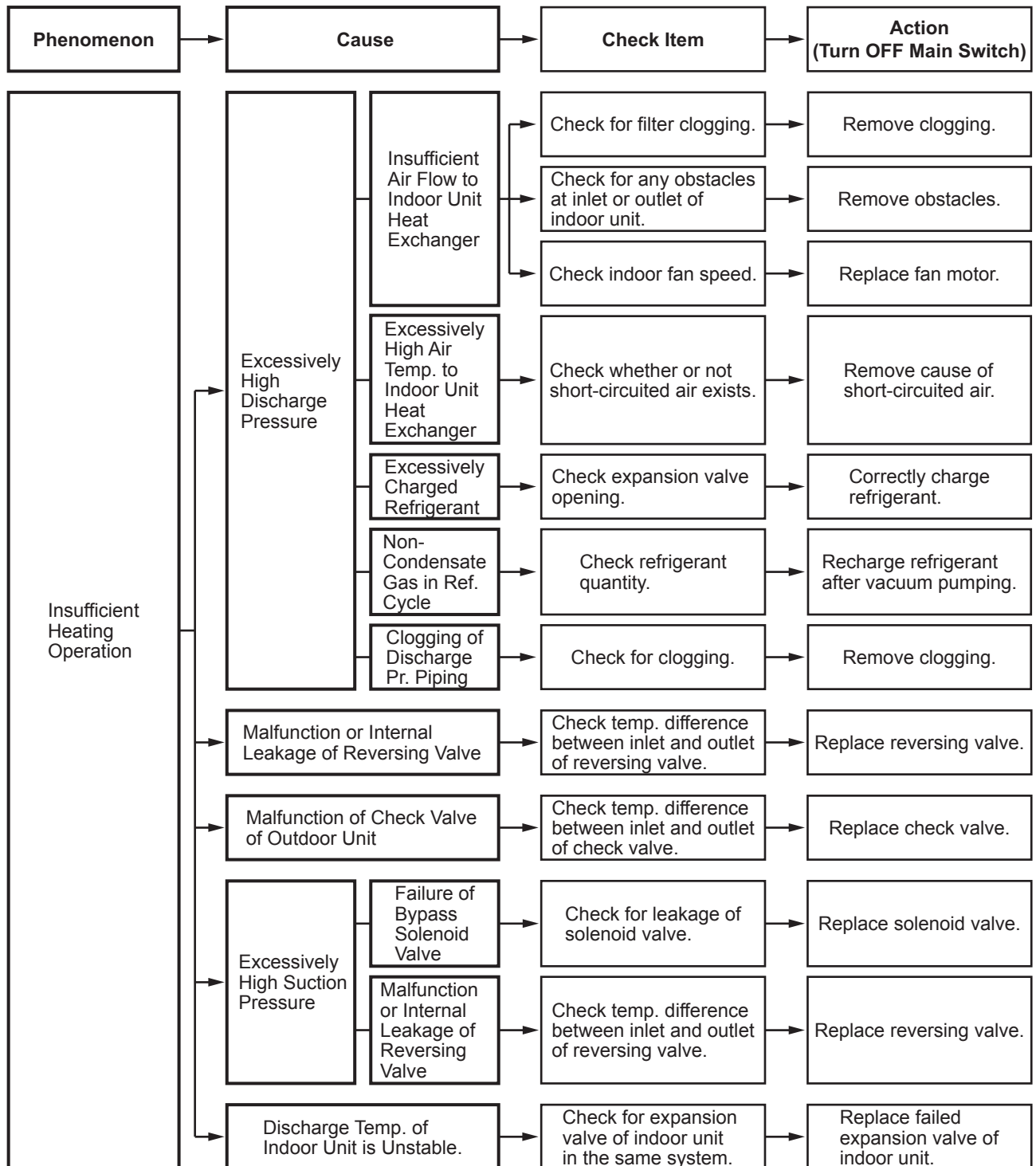

(1.1.9 Abnormalities of Devices)

Phenomenon	Cause	Check Item	Action (Turn OFF Main Switch)	
Cooling or Heating Operation with Abnormal Sound	Foreign Particles Inside of Fan Casing	Check it by viewing.	Remove foreign particles.	
	Indoor Unit Fan Runner is Hitting Casing	Check it by viewing.	Adjust position of fan runner.	
	Outdoor Unit Propeller Fan is Hitting Shroud	Check it by viewing.	Adjust position of propeller fan.	
	Abnormal Sound from Compressor	Faulty Installation	Check each part is tightly fixed.	Tightly fix it.
		Liquid Ref. Compression	Check expansion valve opening.	Ensure superheat.
		Wear or Breakage of Internal Comp. Parts	Abnormal Sound from Inside of Compressor	Replace compressor.
		No Heating by Crankcase Heater	Check resistance. (Crankcase Heater, Fuse)	Replace crankcase heater or fuse.
	Hamming Sound from Magnetic Contactor	Check surface of contacts.	Replace magnetic switch.	
Abnormal Vibration of Cabinets	Check each fixing screws.	Tightly fix it.		
Outdoor Fan is Not Operated When Compressor is Operated	Obstacle at Outdoor Fan	Check obstacles.	Remove obstacles.	
	Watching Condition for Heating Operation	Wait for switching of reversing valve. (1 to 3 minutes)	In case that reversing valve is not switched, check for insufficient refrigerant.	
Indoor Fan is Not Operated When Compressor is Operated	Discharge Pressure Does Not Increase Higher than 1.5MPa due to insufficient refrigerant.	Check operation pressure.	Add refrigerant.	
	Disconnected Wiring for Indoor Fan	Check wiring.	Connect wiring correctly.	
	Failure of DC module	Check DC module.	Replace DC module.	

1.2 Troubleshooting Procedure

- Alarm Code Indication of Remote Control Switch

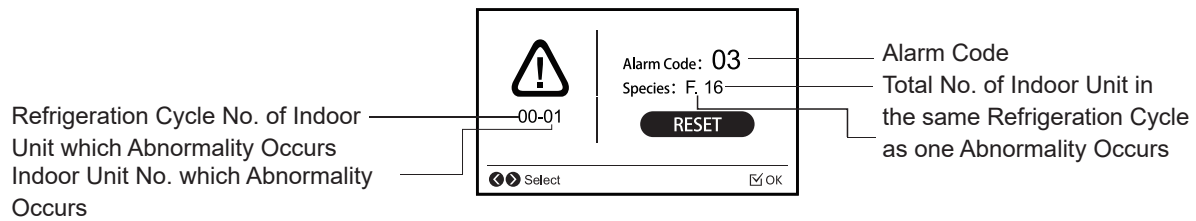

1.2.1 Alarm Code Table

Code	Category	Content of Abnormality	Leading Cause
01	Indoor Unit	Activation of Protection Device (Float Switch)	Activation of Float Switch (High Water Level in Drain Pan, Abnormality of Drain Pipe, Float Switch or Drain Pan)
02	Outdoor Unit	Activation of Protection Device (High Pressure Cut)	Activation of PSH (Pipe Clogging, Excessive Refrigerant, Inert Gas Mixing)
03	Transmission	Abnormality between Indoor and Outdoor	Incorrect Wiring, Loose Terminals, Disconnect Wire, Blowout of Fuse, Outdoor Unit Power OFF
04		Abnormality between Inverter PCB and Outdoor Unit PCB	Inverter PCB - Outdoor Unit PCB Transmission Failure (Loose Connector, Wire Breaking, Blowout of Fuse)
04.		Abnormality between Fan Controller and Outdoor Unit PCB	Fan Controller - Outdoor Unit PCB Transmission Failure (Loose Connector, Wire Breaking, Blowout of Fuse)
05	Supply Phase	Abnormality Power Supply Phases	Incorrect Power Supply, Connection to Reversed Phase, Open-Phase
06	Voltage	Abnormal Inverter Voltage	Outdoor Voltage Drop, Insufficient Power Capacit
06.		Abnormal Fan Controller Voltage	Outdoor Voltage Drop, Insufficient Power Capacit
07	Cycle	Decrease in Discharge Gas Superheat	Excessive Refrigerant Charge, Failure of Thermistor, Incorrect Wiring, Incorrect Piping Connection, Expansion Valve Locking at Opened Position (Disconnect Connector)
08		Increase in Discharge Gas Temperature	Insufficient Refrigerant Charge, Pipe Clogging Failure of Thermistor, Incorrect Wiring, Incorrect Piping Connection, Expansion Valve Locking at Closed Position (Disconnect Connector)
0A	Transmission	Abnormality between Outdoor and Outdoor	Incorrect Wiring, Breaking Wire, Loose Terminals
0b	Outdoor Unit	Incorrect Outdoor Unit Address Setting	Duplication of Address Setting for Outdoor Units (Sub Units) in Same Refrigerant Cycle System
0C		Incorrect Outdoor Unit Main Unit Setting	Two (or more) Outdoor Units Set as "Main Unit" Exist in Same Refrigerant Cycle System
11	Sensor on Indoor Unit/ Water Module Controller	Inlet Air Thermistor/ Inlet Water Thermistor	Incorrect Wiring, Disconnecting Wiring Breaking Wire, Short Circuit
12		Outlet Air Thermistor/ Outlet Water Thermistor	
13		Freeze Protection Thermistor	
14		Gas Piping Thermistor	
19	Fan Motor	Activation of Protection Device for Indoor Fan	Fan Motor Overheat, Locking
21	Sensor on Outdoor Unit	High Pressure Sensor	Incorrect Wiring, Disconnecting Wiring Breaking Wire, Short Circuit
22		Outdoor Air Thermistor	
23		Discharge Gas Thermistor on Top of Compressor	
24		Heat Exchanger Liquid Pipe Thermistor	
25		Heat Exchanger Gas Pipe Thermistor	
29		Low Pressure Sensor	
31	System	Incorrect Capacity Setting of Outdoor Unit and Indoor Unit/water module	Incorrect Capacity Code Setting of Combination Excessive or Insufficient Indoor Unit /Water Module Total Capacity Code
35		Abnormal Transmitting between Outdoor Units	Duplication of Indoor Unit No. in same Ref. Gr.
36		Incorrect Setting of Indoor Unit No.	Indoor Unit is Designed for R22
38	System	Abnormality of Picking up Circuit for Protection in Outdoor Unit	Failure of Protection Detecting Device (Incorrect Wiring of Outdoor Unit PCB)

Code	Category	Content of Abnormality	Leading Cause
3A	Outdoor Unit	Abnormality of Outdoor Unit Capacity	Outdoor Unit Capacity Over the Range
3b		Incorrect Setting of Outdoor Unit Models Combination or Voltage	Incorrect Setting of Main and Sub Unit(s) Combination or Voltage
3d		Abnormality Transmission between Main Unit and Sub Unit(s)	Incorrect Wiring, Disconnect Wire, Breaking Wire, PCB Failure
43	Protection Device	Activation of Low Compression Ratio Protection Device	Defective Compression (Failure of Compressor of Inverter, Loose Power Supply Connection)
44		Activation of Low Pressure Increase Protection Device	Overload at Cooling, High Temperature at Heating, Expansion Valve Locking (Loose Connector)
45		Activation of High Pressure Increase Protection Device	Overload Operation (Clogging, Short-Pass), Pipe Clogging, Excessive Refrigerant, Inert Gas Mixing
47		Activation of Low Pressure Decrease Protection Device (Vacuum Operation Protection)	Insufficient Refrigerant, Refrigerant Piping, Clogging, Expansion Valve Locking at Open Position (Loose Connector)
48		Activation of Inverter Overcurrent Protection Device	Overload Operation, Compressor Failure
51	Sensor	Abnormal Inverter Current Sensor	Current Sensor Failure
53	Inverter	Inverter Error Signal Detection	Driver IC Error Signal Detection (Protection for Overcurrent, Low Voltage, Short Circuit)
54		Abnormality of Inverter Fin Temperature	Abnormal Inverter Fin Thermistor, Heat Exchanger Clogging, Fan Motor Failure
55		Inverter Failure	Inverter PCB Failure
57	Fan Controller	Activation of Fan Controller Protection	Driver IC Error Signal Detection (Protection for Overcurrent, Low Voltage, Short Circuit), Instantaneous Overcurrent
5A		Abnormality of Fan Controller Fin Temperature	Fin Thermistor Failure, Heat Exchanger Clogging, Fan Motor Failure
5b		Activation of Overcurrent Protection	Fan Motor Failure
5C		Abnormality of Fan Controller Sensor	Failure of Current Sensor (Instantaneous Overcurrent, Increase of Fin Temperature, Low Voltage, Earth Fault, Step-Out)
EE	Compressor	Compressor Protection Alarm (It is can not be reset from remote controller)	This alarm code appears when the following alarms* occurs three times within 6 hours. *02, 07, 08, 43 to 45, 47
A6	Inverter	Abnormality of Refrigerant Cooling Module Temperature	Insufficient Refrigerant, or Abnormal EVO or MV5
b1	Outdoor Unit No. Setting	Incorrect Setting of Unit and Refrigerant Cycle No.	Over 64 Number is Set for Address or Refrigerant Cycle.
b5	Indoor Unit No. Setting	Incorrect Indoor Unit Connection Number Setting	More than 17 Non-Corresponding to H-NET Units are Connected to One System.

1.2.2 Troubleshooting by Alarm Code

Alarm Code	01	Activation of Protection Device (Float Switch) in Indoor Unit
------------	----	---

- The RUN indicator (Red) is flashing.
 - The indoor unit number, the alarm code, the unit model code and the connected number of indoor units are displayed on LCD. Meanwhile, the indoor unit number and the alarm code are displayed on the 7-segment of outdoor unit PCB.
- ★ This alarm code is indicated when the contact between #1 and #2 of CN14 is opened for over 120 seconds during the cooling, dry, fan or heating operation.

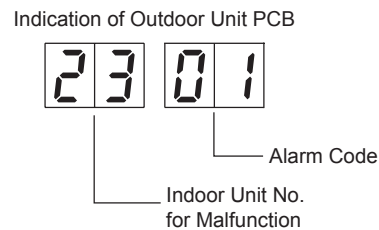
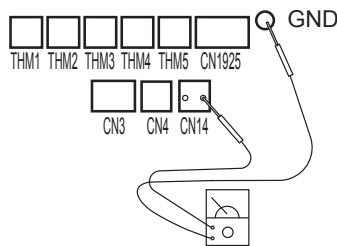
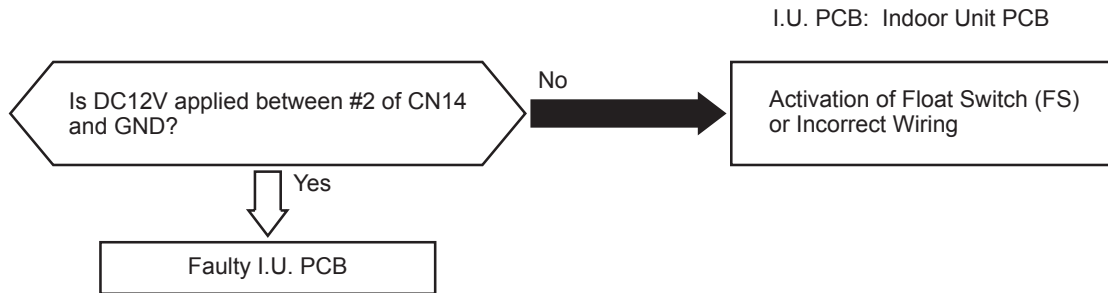

Phenomenon	Cause	Check Item	Action (Turn OFF Main Switch)
Activation of Float Switch	High Drain Level	Clogging of Drainage Up-Slope Drain Piping	Check drain pan. Check drainage by pouring water.
	Faulty Float Switch	Fault	Check conduction when drain level is low.
		Faulty Contacting	Measure resistance by tester.
		Faulty Connection	Check connections.
Faulty Indoor Unit PCB		Check PCB by self-checking .	Replace it if faulty.

Alarm Code	02	Activation of Protection Device in Outdoor Unit
------------	----	---

- The RUN indicator (Red) is flashing.
 - The indoor unit number, the alarm code, the unit model code and the connected number of indoor units are displayed on LCD. Meanwhile, the indoor unit number and the alarm code are displayed on the 7-segment of outdoor unit PCB.
- ★ This alarm code is indicated when the high pressure switch (PSH) is activated during the compressor operation .

Check activation of the following safety devices. Remove the cause after checking.
High Pressure Switch (PSH): 4.15MPa

Model	High Pressure Switch (Connector No.)	
	PSH1 (PCN2)	PSH2 (PCN16)
Single compressor	○	-
Dual compressor	○	○

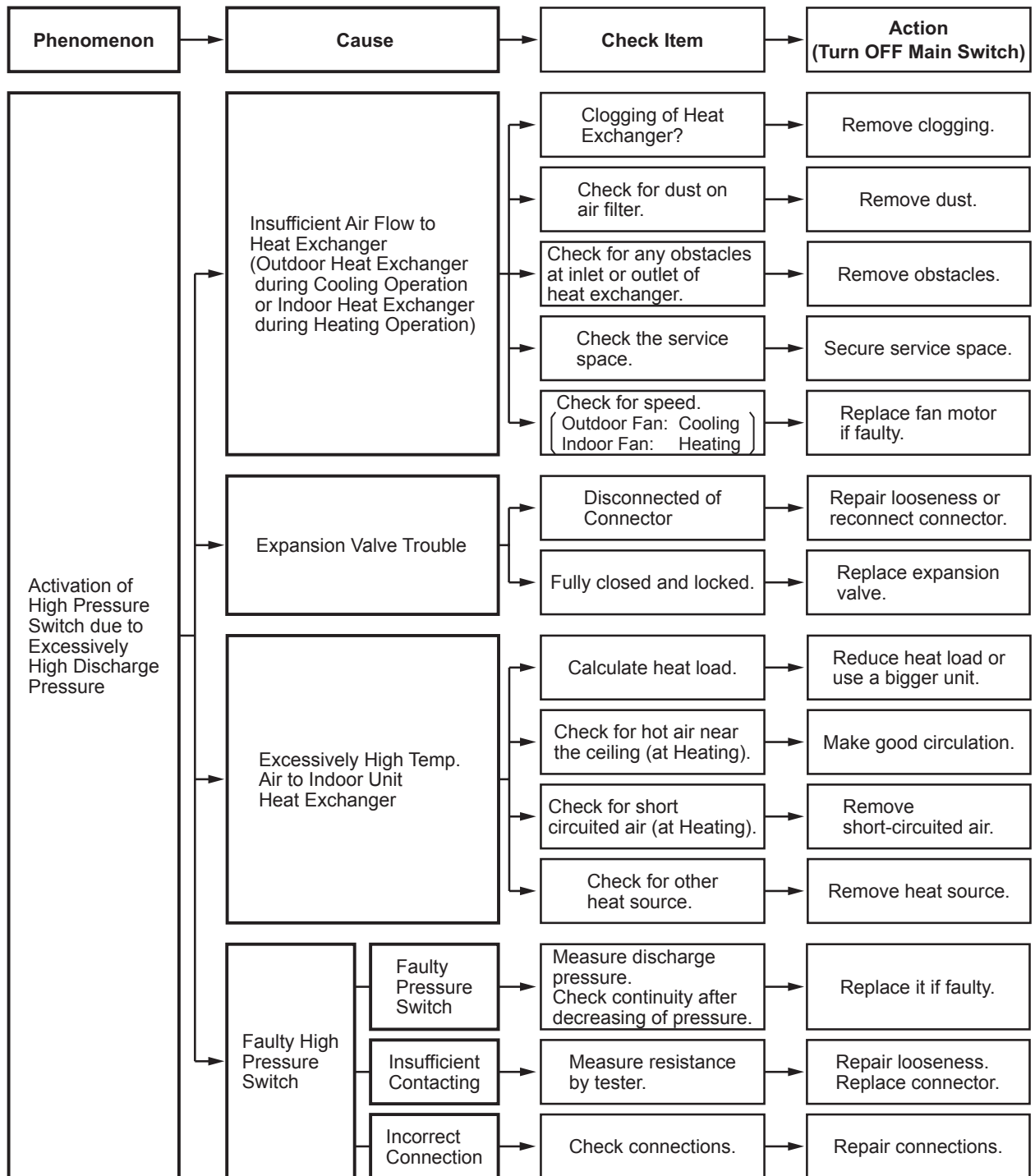

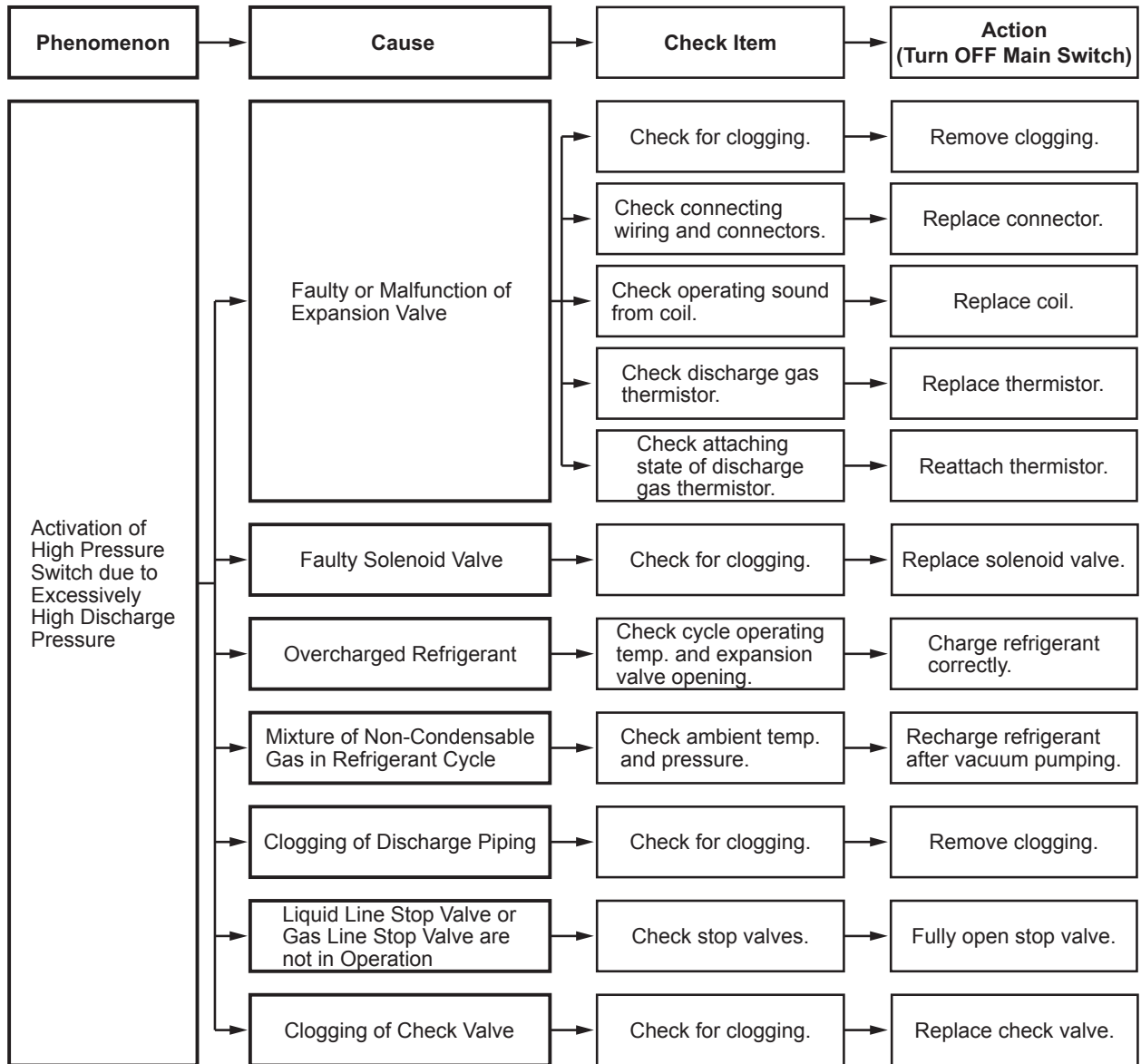

Alarm Code 03	Abnormal Transmitting between Indoor Units and Outdoor Units
----------------------	--

- The RUN indicator (Red) is flashing.
- The indoor unit number, the alarm code, the unit model code and the connected number of indoor units are displayed on LCD, or the indoor unit number and the alarm code are displayed on the 7-segment of outdoor unit PCB.

- ★ When fuses are melted, or the circuit breakers are activated, check the cause of overcurrent and take action.
- ★ This alarm code is indicated when abnormality continues for 3 minutes after normal transmitting between indoor units and outdoor units, and also abnormal transmitting continues for 30 seconds after the micro-computer is automatically reset. If the abnormal transmitting occurs from the first, the alarm code is indicated after 30 seconds from starting the outdoor unit.

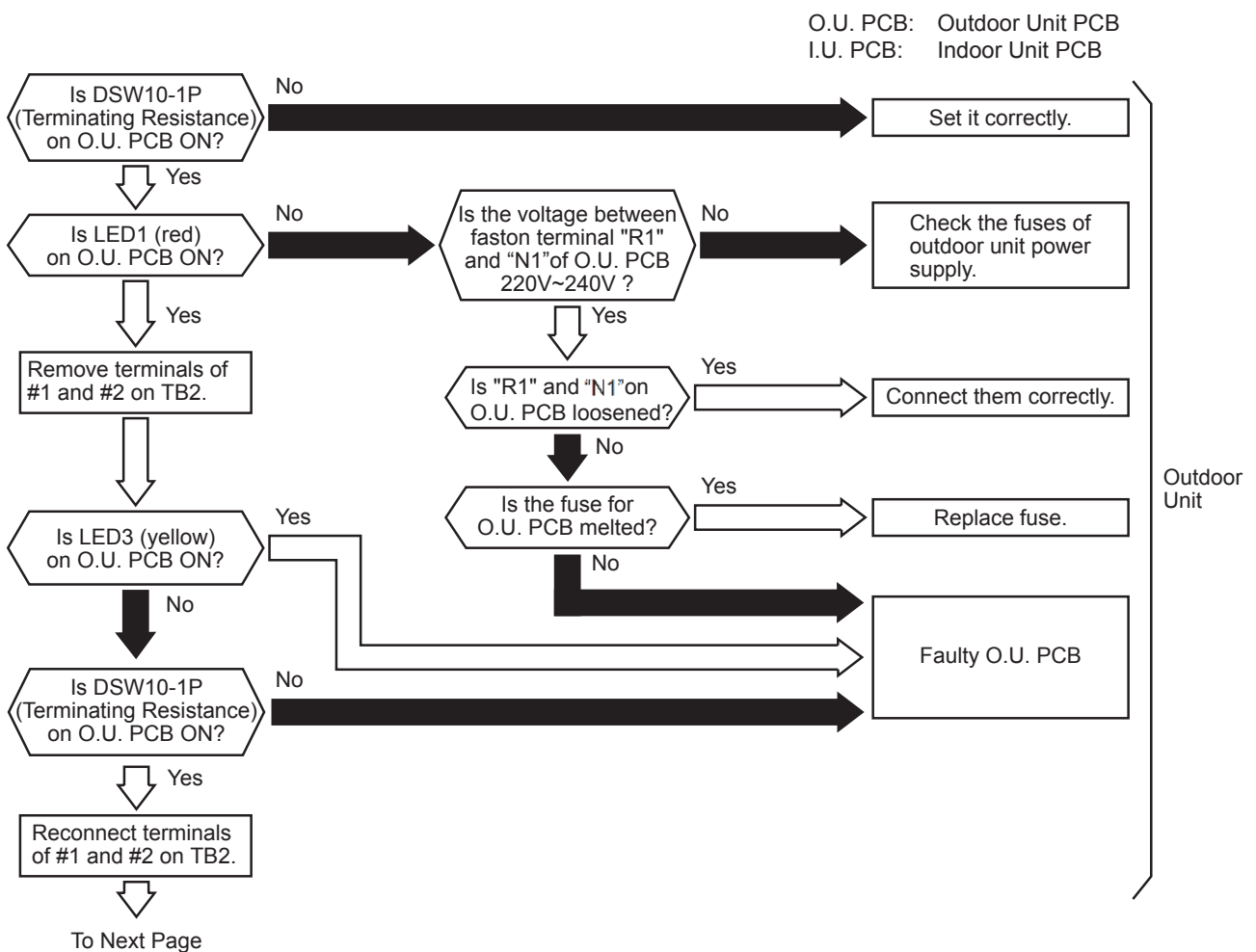

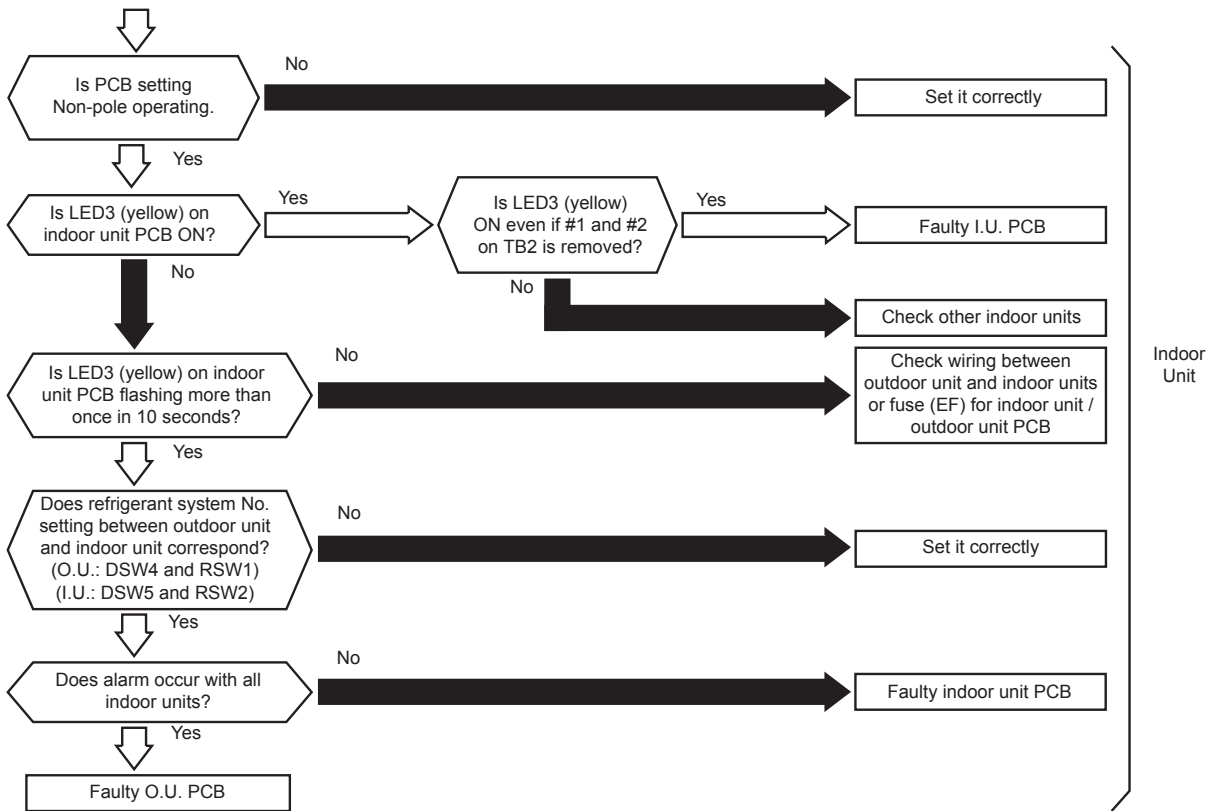

Phenomenon	Cause	Check Item	Action (Turn OFF Main Switch)
Power Failure of No Power Supply		Measure voltage by tester.	Supply power.
Melted Fuse for Power Source or Activation of Breaker (Outdoor Unit)	Short Circuit between Wires	Check for breakage of insulation.	Remove cause of short circuit. Replace fuse and/or I.U./O.U. PCB if faulty.
	Short Circuited Wire to Ground	Measure insulation resistance.	Remove cause of short circuit to ground. Replace fuse and/or I.U./O.U. PCB if faulty.
	Faulty Comp. Motor	Measure resistance between wires and insulation resistance.	Replace comp. and fuse. (O.U.) Replace inverter PCB and/or PCB if faulty. (O.U.)
	Faulty Outdoor Unit Fan Motor	Measure resistance between wires and insulation resistance.	Replace outdoor unit fan motor and fuse. Replace O.U. PCB if faulty.
Melted Fuse on PCB (Outdoor Unit)	Short Circuit between Wires	Check for breakage of insulation.	Remove cause of short circuit and replace fuse.
	Short Circuit (to Ground)	Measure insulation resistance.	Remove cause of short circuit and replace fuse.
	Faulty Solenoid Coil for Magnetic Switch (CMC) for Comp. Motor	Measure resistance of coil.	Replace magnetic switch (CMC) and fuse.
	Failure of Outdoor Unit Fan Motor	Measure resistance between wires and insulation resistance.	Replace fan motor and fuse.
Incorrect Power Supply Circuit of O.U. PCB		Measure O.U. PCB output.	Replace O.U. PCB.
Disconnected Wires Insufficient Contacting or Incorrect Connection	Between Outdoor Unit and Indoor Unit	Check continuity of wires. Check for looseness of connection screws. Check terminal Nos.	Replacing wires, repairing and tightening screws.
	Power Source Wiring for Outdoor Unit		Correctly connect wires.
Faulty PCB (Outdoor Unit, Indoor Unit)	Disconnected Wires to I.U./O.U. PCB	Check connections.	Correctly connect wires.
	Faulty I.U./O.U.PCB		Replace it if faulty.
Incorrect Wiring	Disconnected Wire Insufficient Contacting	Check continuity and looseness of connection screws.	Replacing Wires, Repairing and Tightening Screws
	Incorrect Wiring	Check terminal Nos.	Correctly connect wires.

O.U. PCB: Outdoor Unit PCB
I.U. PCB: Indoor Unit PCB

Alarm Code	04	Abnormal Transmitting between Inverter PCB and Outdoor Unit PCB
------------	----	---

- The RUN indicator (Red) is flashing.
- The indoor unit number, the alarm code, the unit model code and the connected number of indoor units are displayed on LCD. Meanwhile, the indoor unit number and the alarm code are displayed on the 7-segment of outdoor unit PCB.

★ This alarm code is indicated when abnormality continues for 30 seconds after normal transmitting between the outdoor unit PCB and inverter PCB, and also abnormality continues for 30 seconds after the micro-computer is automatically reset. The alarm is indicated when the abnormal transmitting continues for 30 seconds from starting of the outdoor unit.

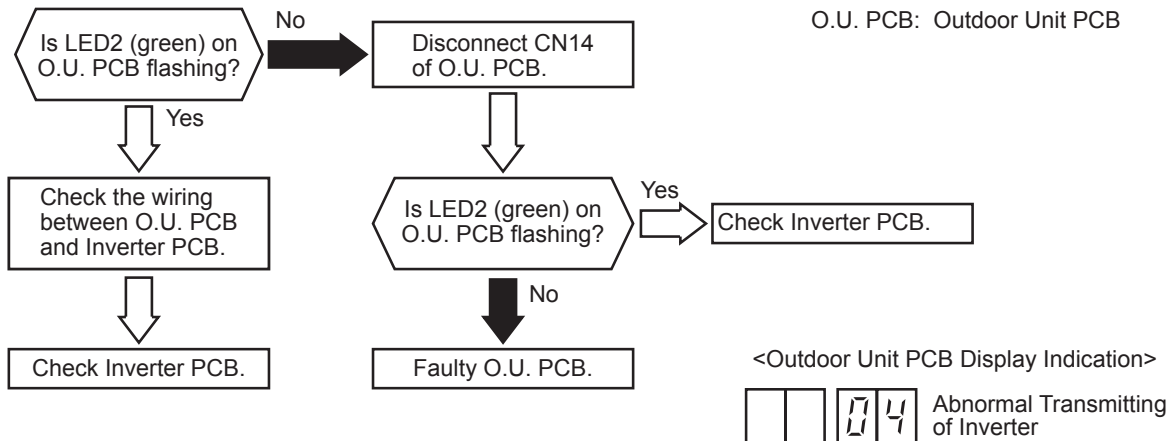

Phenomenon	Cause	Check Item	Action (Turn OFF Main Switch)
Disconnected Wires, Insufficient Contacting or Incorrect Connection	Between O.U. PCB and inverter PCB	Check continuity of wires. Check for looseness of connection screws. Check connection No.	Replacing wires, repairing, tightening screws and incorrect wiring.
	Power Source Wiring for Outdoor Unit		
Faulty O.U. PCB and inverter PCB	Disconnected Wires to PCB	Check connections.	Repair wiring connections.
	Faulty PCB		Replace PCB if faulty.
Faulty Electrical Components (Power Fuse, Resistance)	Melted Power Fuse	Check conductivity of power fuse, power transistor, diode module.	Replace power fuse, power transistor, and diode module.
	Disconnected Incoming Current Limit Resistance	Check resistance of incoming current limit resistance.	Replace incoming current limit resistance.
Incorrect Wiring	Disconnected Wires Insufficient Contacting	Check continuity. Check for looseness of connection screws.	Replacing Wires, Repairing and Tightening Screws
	Incorrect Wiring	Check connection Nos.	Correctly Connect Wires

*1): When the unit is applied with excessive surge current due to lighting or other causes, this alarm code "04" will be indicated and the unit can not be operated. In this case, check to ensure the surge absorber/surge arrester (SA) on the noise filter (NF1, NF2). The surge absorber may be damaged if the inner surface of the surge absorber is black. In that case, replace the surge absorber. If the inside of the surge absorber is normal, turn OFF the power once and wait until LED4 on inverter PCB is OFF (approx. 5 min.) and turn ON again.

< Position of Surge Absorber >

76/96 Models

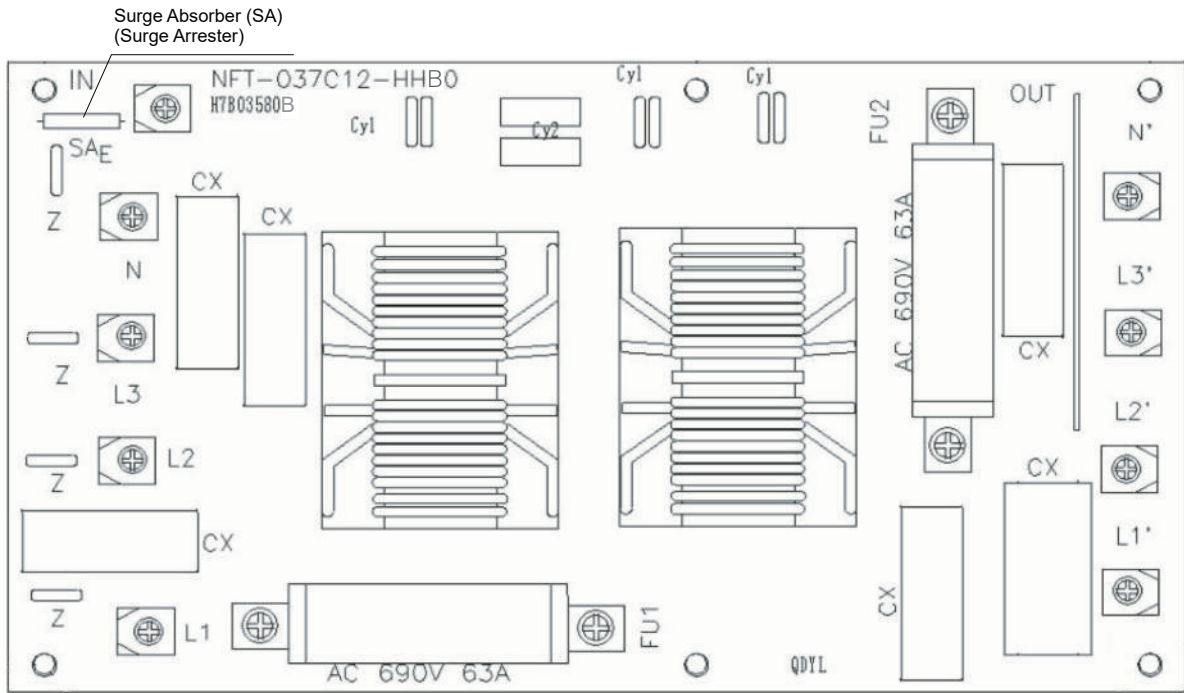

114-272 Models

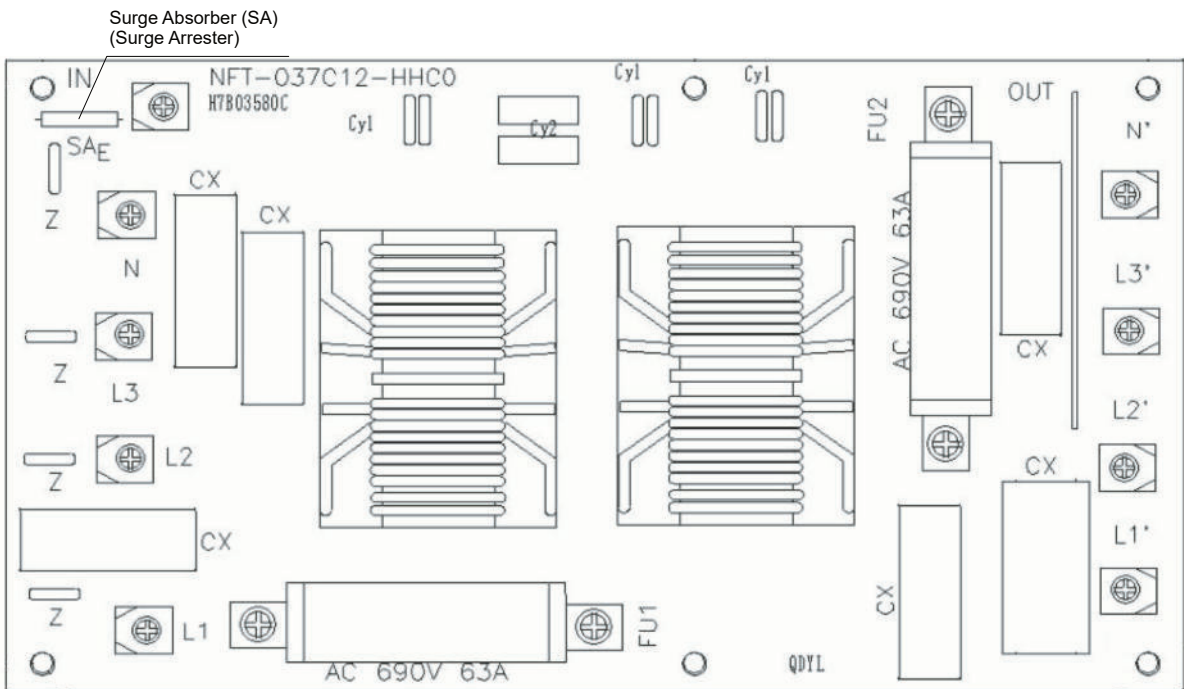

Alarm Code 04.	Abnormal Transmitting between Inverter PCB and Fan Controller
---	--

- The RUN indicator (Red) is flashing.
- The indoor unit number, the alarm code, the unit model code and the connected number of indoor units are displayed on LCD. Meanwhile, the indoor unit number and the alarm code are displayed on the 7-segment of outdoor unit PCB.

★ This alarm code is indicated when abnormality continues for 30 seconds after normal transmitting between the outdoor unit PCB and fan controller, and also abnormality continues for 30 seconds after the micro-computer is automatically reset. The alarm is indicated when the abnormal transmitting continues for 30 seconds from starting of the outdoor unit.

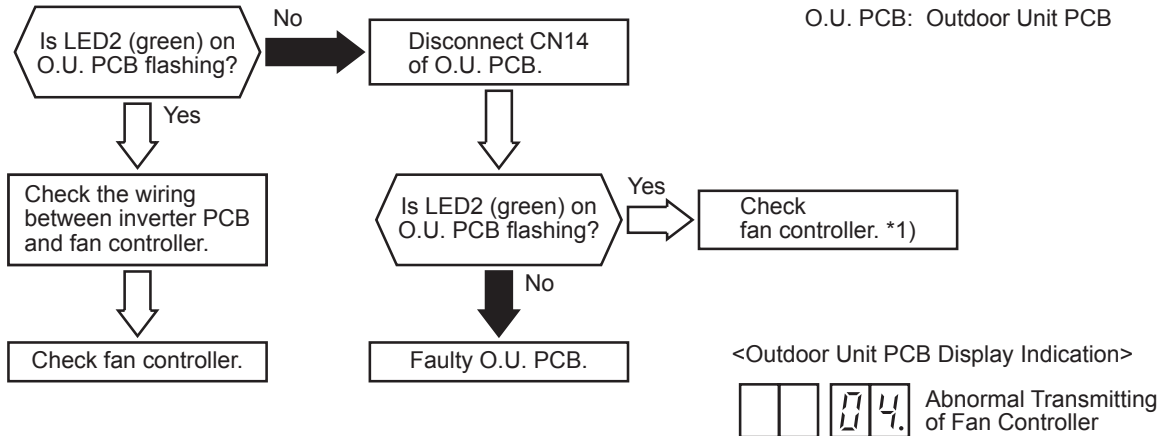

Phenomenon	Cause	Check Item	Action (Turn OFF Main Switch)
Disconnected Wires, Insufficient Contacting or Incorrect Connection	Between O.U. PCB, Inverter PCB and Fan Controller	Check continuity of wires. Check for looseness of connection screws. Check connection No.	Replacing wires, repairing, tightening screws and incorrect wiring.
	Power Source Wiring for Outdoor Unit		
Faulty O.U. PCB, Inverter PCB and Fan Controller	Disconnected Wires to PCB	Check connections.	Repair wiring connections.
	Faulty PCB		Replace PCB if faulty.
	Melted Fuse (Fan Controller)	Check conductivity of fuse.	Replace fan controller. *1)
Faulty Electrical Components (Power Fuse, Resistance)	Melted Power Fuse	Check conductivity of power fuse, power transistor, diode module.	Replace power fuse, power transistor, and diode module.
	Disconnected Incoming Current Limit Resistance	Check resistance of incoming current limit resistance.	Replace incoming current limit resistance.
Incorrect Wiring	Disconnected Wires Insufficient Contacting	Check continuity. Check for looseness of connection screws.	Replacing Wires, Repairing and Tightening Screws
	Incorrect Wiring	Check connection Nos.	Correctly Connect Wires

*1): The fan controller may be damaged if the fuse of fan controller is melted. In that case, replace the fan controller.

Alarm Code	05	Abnormality Power Source Phase
------------	----	--------------------------------

- The RUN indicator (Red) is flashing.
- The indoor unit number, the alarm code, the unit model code and the connected number of indoor units are displayed on LCD. Meanwhile, the indoor unit number and the alarm code are displayed on the 7-segment of outdoor unit PCB.

★ This alarm code is indicated when the main power source phase is reversely connected or one phase is not connected.

O.U. PCB: Outdoor Unit PCB

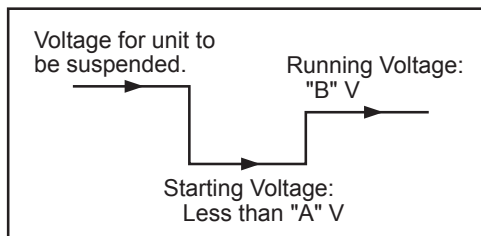
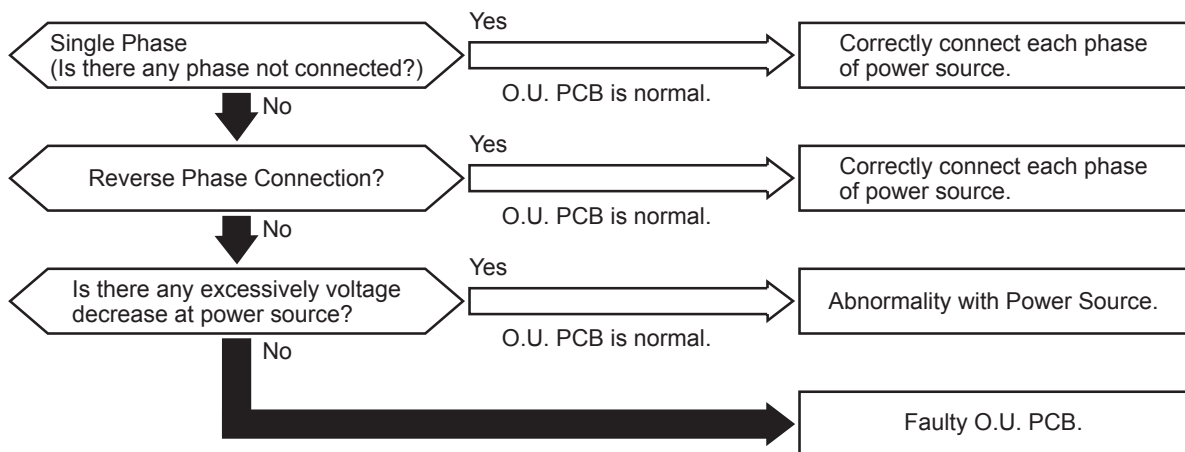

Check Item

Power Supply	"A"	"B"
380-415V/50Hz	323	342 to 456
380V/60Hz	323	342 to 418

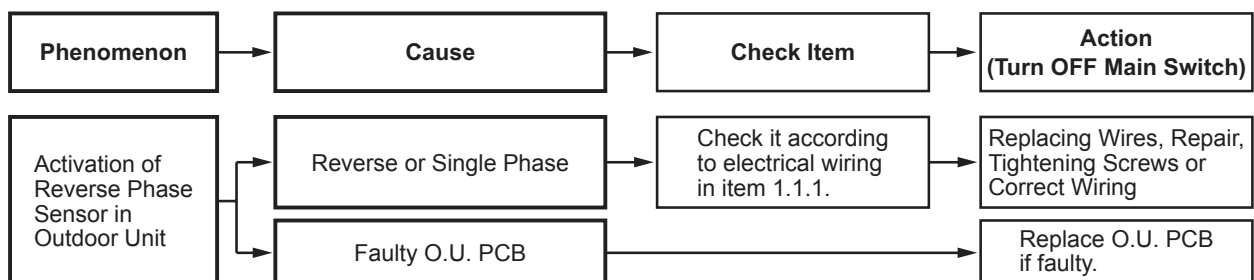

Alarm Code	06	Abnormal Inverter Voltage (Insufficient Inverter Voltage or Overvoltage)
------------	----	--

- The RUN indicator (Red) is flashing.
- The indoor unit number, the alarm code, the unit model code and the connected number of indoor units are displayed on LCD. Meanwhile, the indoor unit number and the alarm code are displayed on the 7-segment of outdoor unit PCB.

★ This alarm code is indicated when voltage between terminal “P” and “N” of transistor module (IPM) is insufficient and this occurs three times in 30 minutes. In the case that it occurs less than twice, retry is performed

<Outdoor Unit PCB Display Indication>

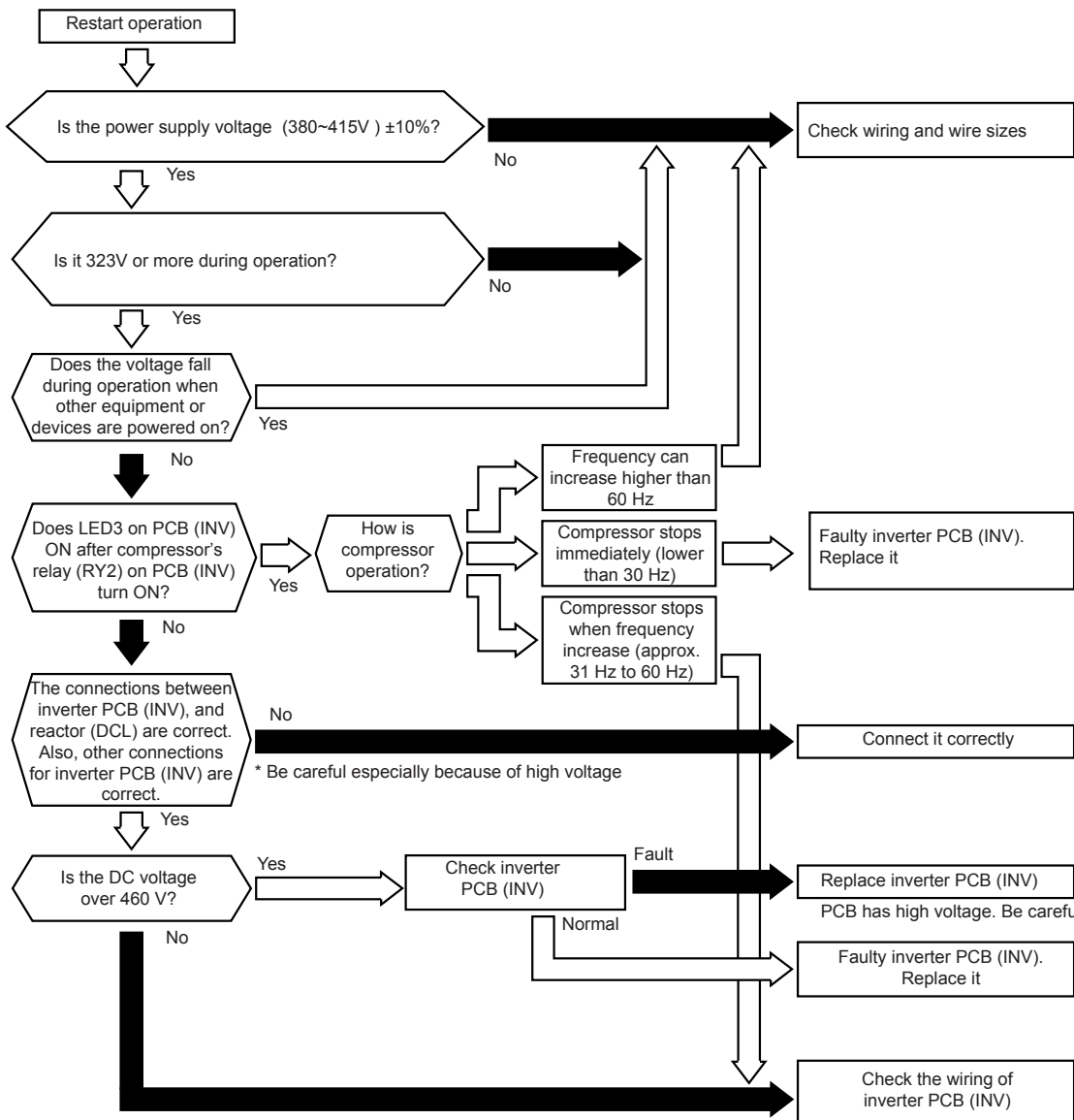

Alarm Code	07	Decrease in Discharge Gas Superheat
------------	----	-------------------------------------

- The RUN indicator (Red) is flashing.
- The indoor unit number, the alarm code, the unit model code and the connected number of indoor units are displayed on LCD. Meanwhile, the indoor unit number and the alarm code are displayed on the 7-segment of outdoor unit PCB.

★ In the case that the discharge gas superheat less than 10 deg. at the top of the compressor continues for 30 minutes, retry operation is performed. However, when the alarm occurs twice within two hours, this alarm code is indicated.

O.U. PCB: Outdoor Unit PCB
I.U. PCB: Indoor Unit PCB

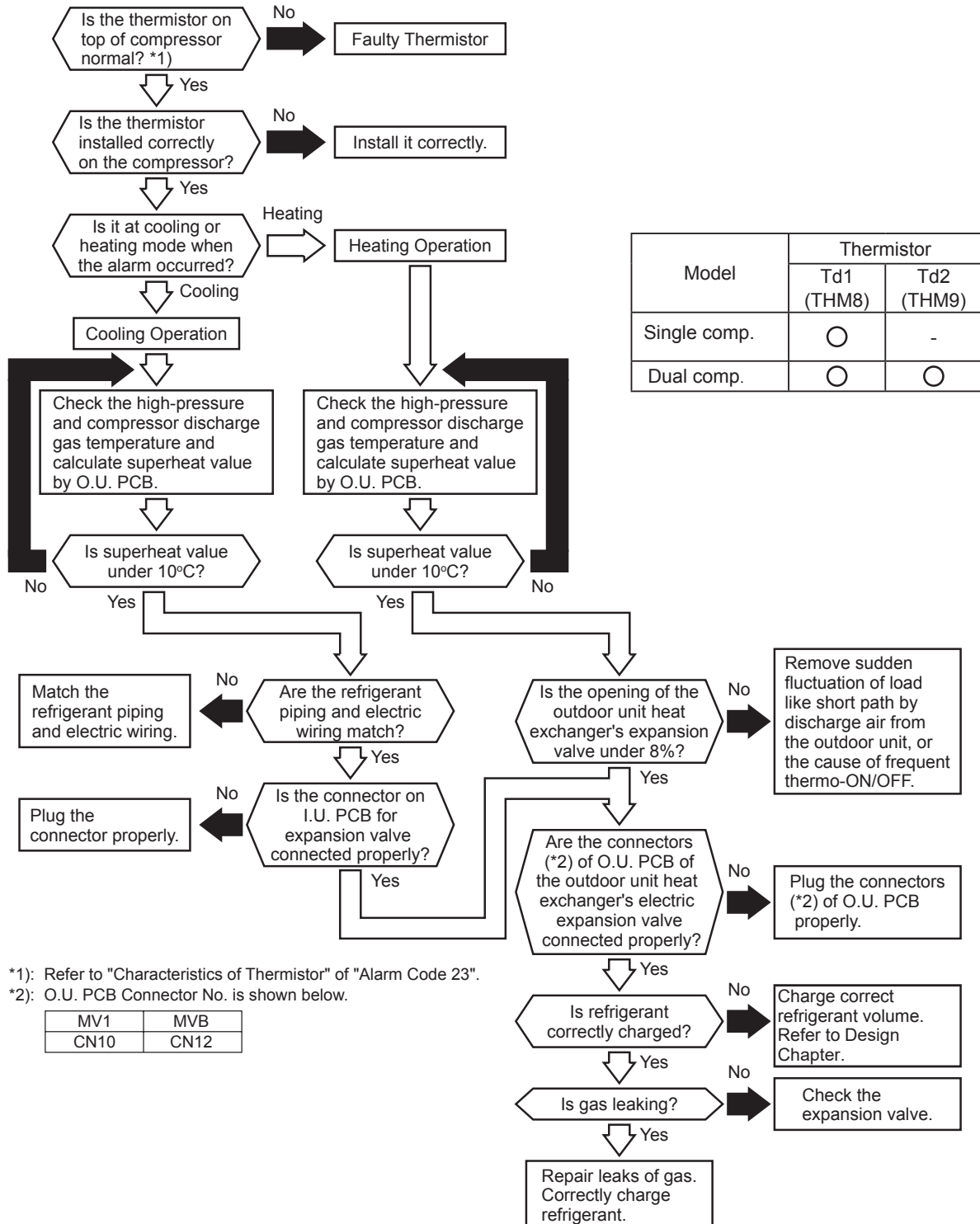

Model	Thermistor	
	Td1 (THM8)	Td2 (THM9)
Single comp.	○	-
Dual comp.	○	○

*1): Refer to "Characteristics of Thermistor" of "Alarm Code 23".

*2): O.U. PCB Connector No. is shown below.

MV1	MVB
CN10	CN12

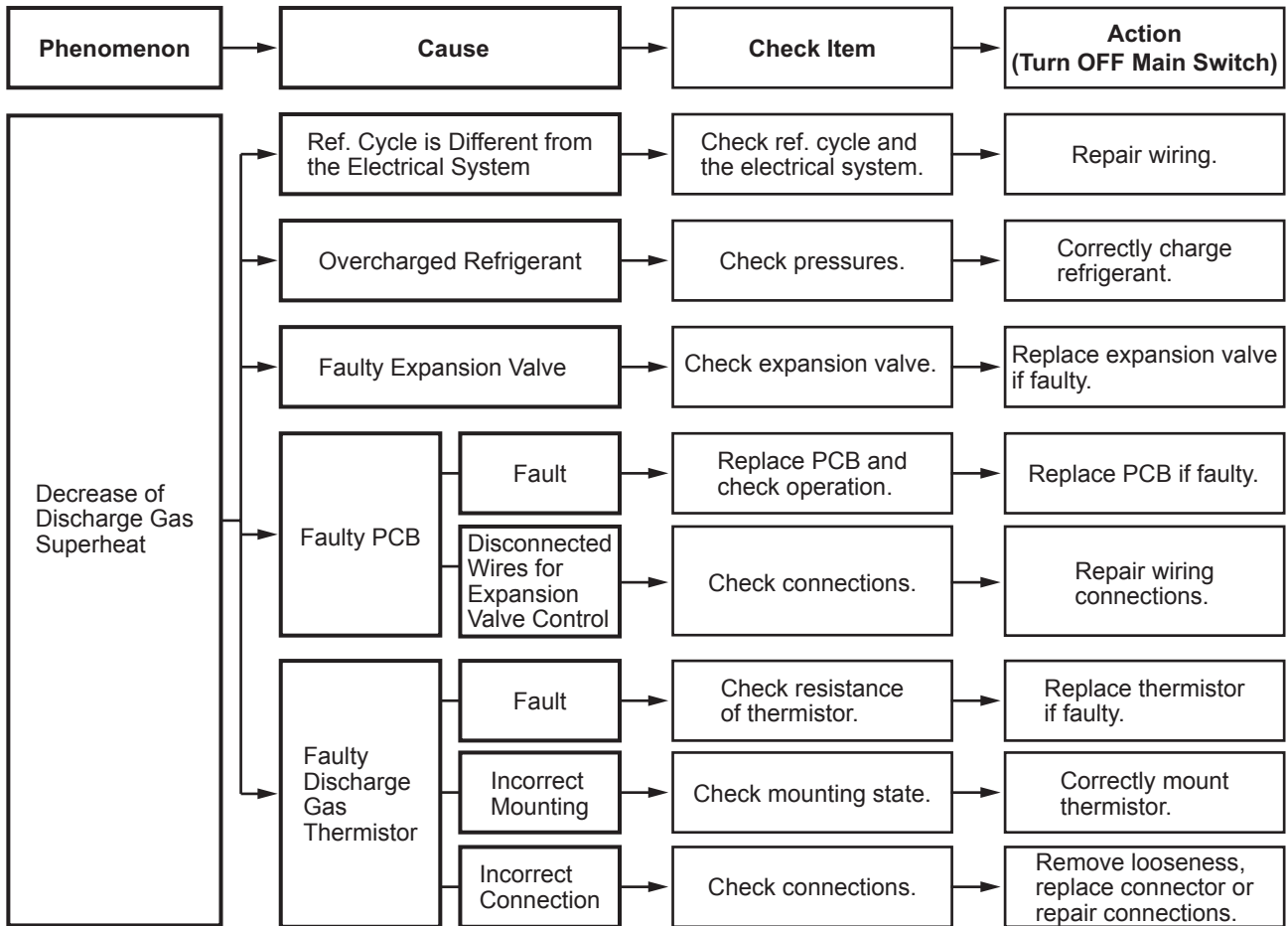

Alarm Code	08	Increase in Discharge Gas Temperature at the Top of Compressor
------------	----	--

- The RUN indicator (Red) is flashing.
- The indoor unit number, the alarm code, the unit model code and the connected number of indoor units are displayed on LCD. Meanwhile, the indoor unit number and the alarm code are displayed on the 7-segment of outdoor unit PCB.

★ When either of the following conditions occurs, retry operation is performed. However, if it occurs three times within one hour, this alarm code is indicated;

- (1) $T_{dmax} \geq 130^{\circ}\text{C}$ lasts for 5 seconds;
or
- (2) $T_{dmax} \geq 125^{\circ}\text{C}$ lasts for 10 minutes.

O.U. PCB: Outdoor Unit PCB

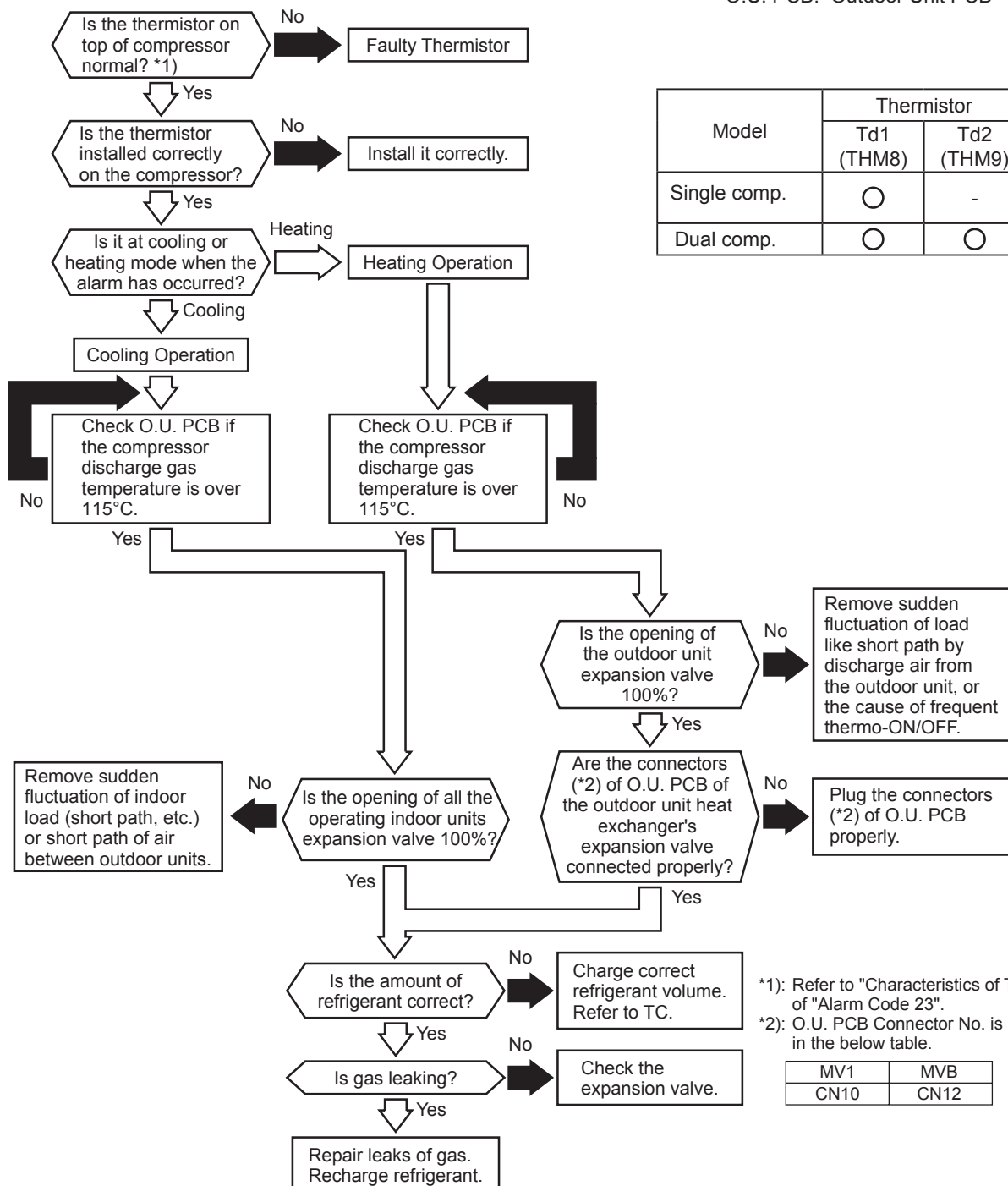

Model	Thermistor	
	Td1 (THM8)	Td2 (THM9)
Single comp.	○	-
Dual comp.	○	○

*1): Refer to "Characteristics of Thermistor" of "Alarm Code 23".
*2): O.U. PCB Connector No. is shown in the below table.

MV1	MVB
CN10	CN12

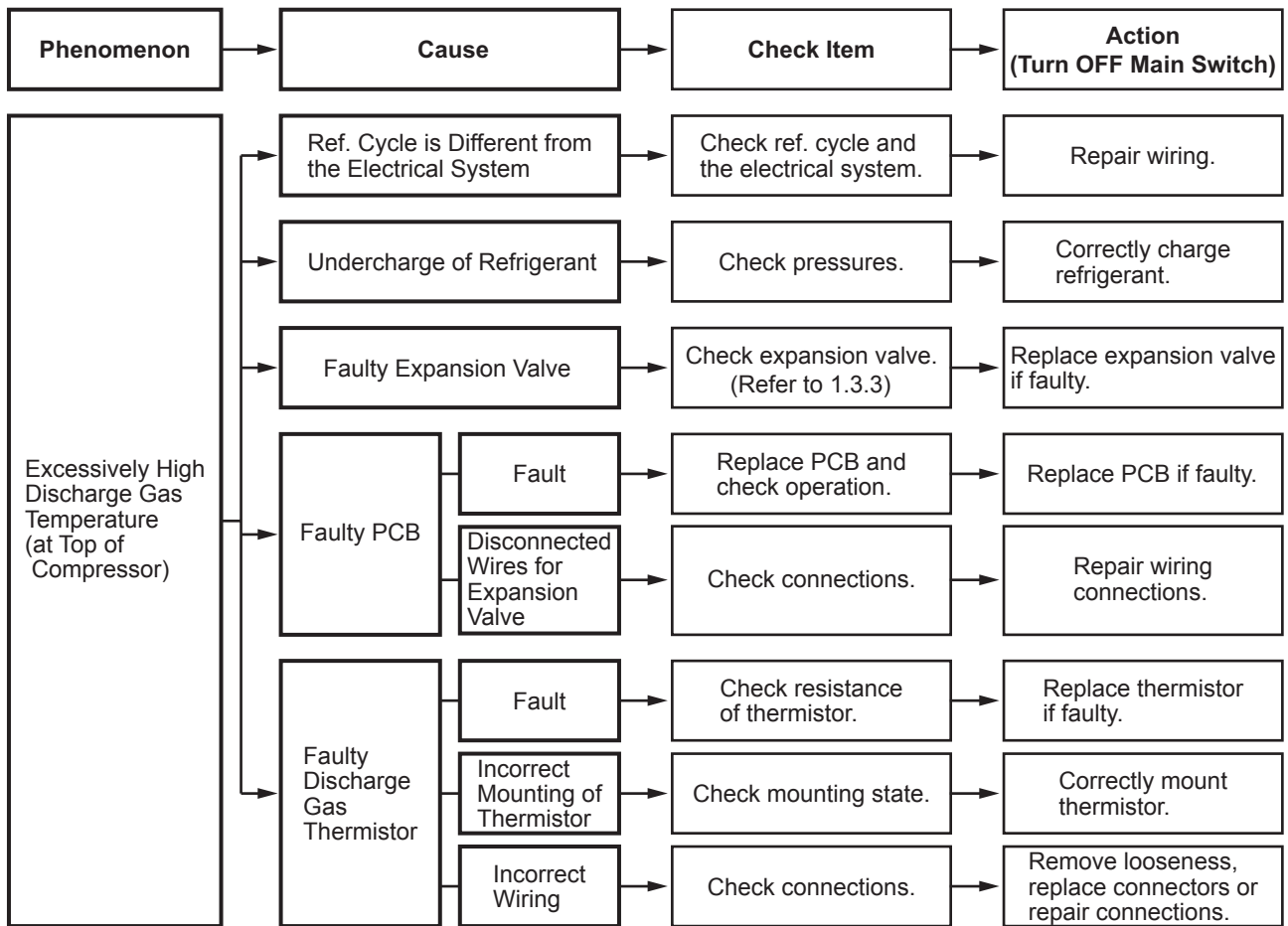

Alarm Code	09	Abnormal Transmitting between Outdoor Units
------------	----	---

- The RUN indicator (Red) is flashing.
- The indoor unit number, the alarm code, the unit model code and the connected number of indoor units are displayed on LCD. Meanwhile, the indoor unit number and the alarm code are displayed on the 7-segment of outdoor unit PCB.

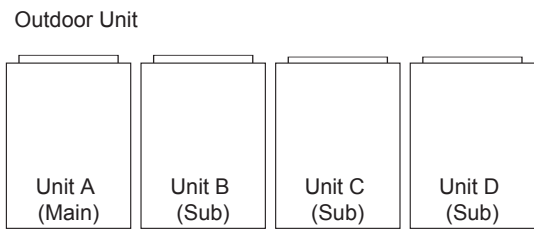
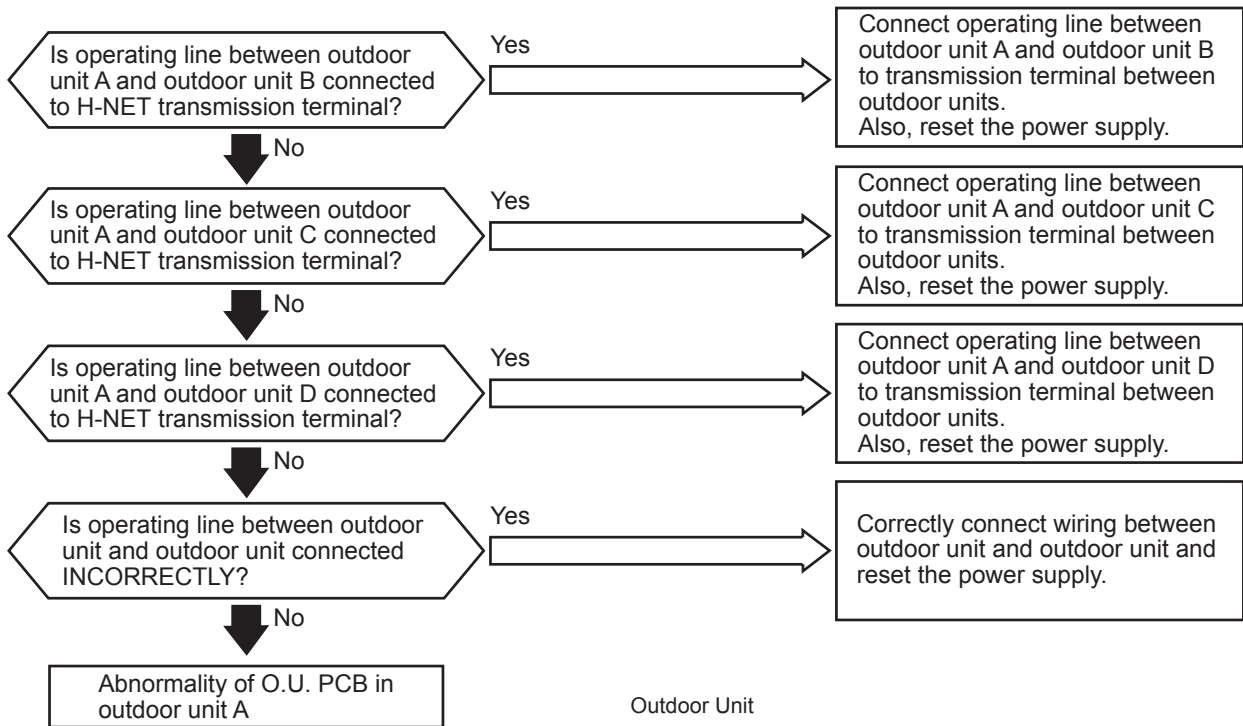

Alarm Code	06	Incorrect Outdoor Unit Address Setting
------------	----	---

- The RUN indicator (Red) is flashing.
- The indoor unit number, the alarm code, the unit model code and the connected number of indoor units are displayed on LCD. Meanwhile, the indoor unit number and the alarm code are displayed on the 7-segment of outdoor unit PCB.

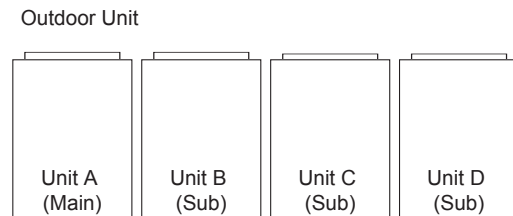
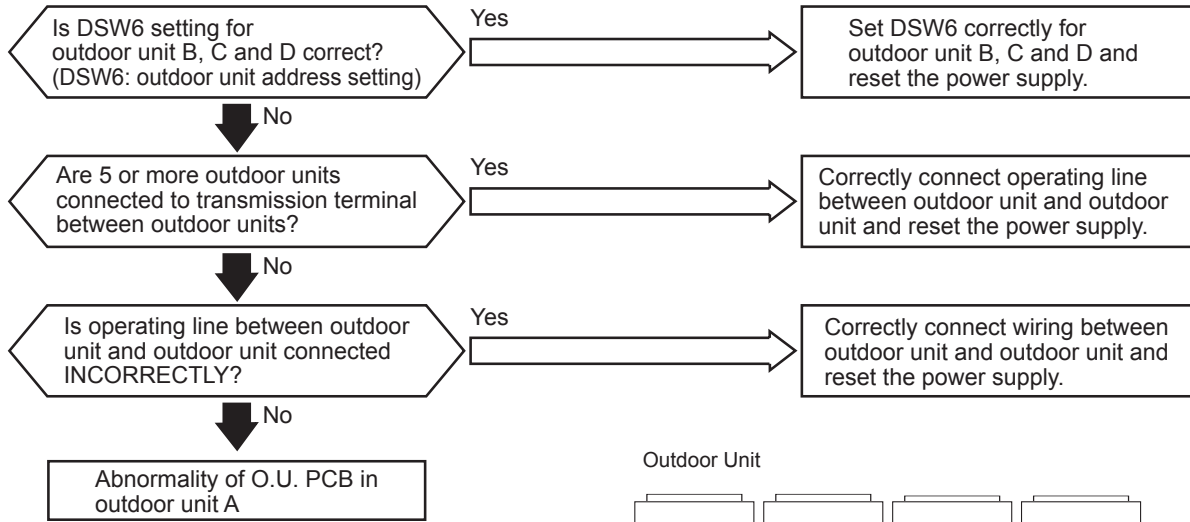

Alarm Code	07	Incorrect Setting of Main Outdoor Unit
------------	----	---

- The RUN indicator (Red) is flashing.
- The indoor unit number, the alarm code, the unit model code and the connected number of indoor units are displayed on LCD. Meanwhile, the indoor unit number and the alarm code are displayed on the 7-segment of outdoor unit PCB.

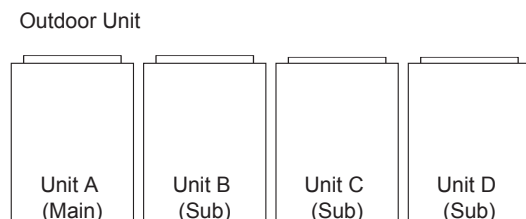
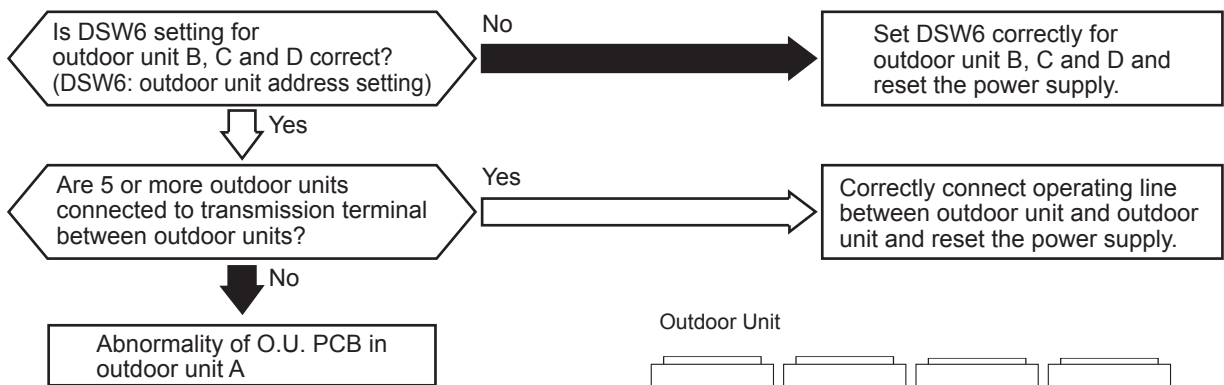

Alarm Code	11	Abnormality of Thermistor for Indoor Unit Inlet Air Temperature (Inlet Air Thermistor)
------------	----	---

- The RUN indicator (Red) is flashing.
- The indoor unit number, the alarm code, the unit model code and the connected number of indoor units are displayed on LCD. Meanwhile, the indoor unit number and the alarm code are displayed on the 7-segment of outdoor unit PCB.

★ This alarm code is indicated when a short circuit (less than 0.24kΩ) or disconnection (more than 840kΩ) of the thermistor is detected during the heating or cooling operation. The operation is automatically restarted when the malfunction is removed.

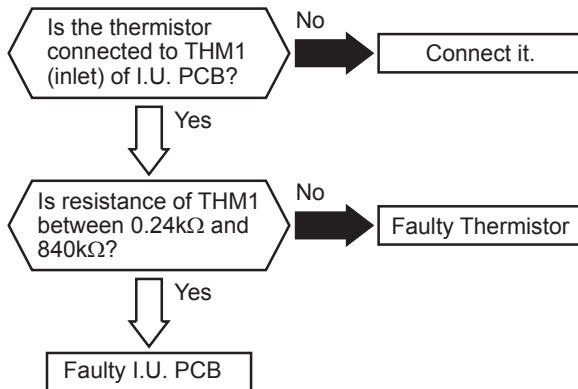

Phenomenon	Cause	Check Item	Action (Turn OFF Main Switch)
Faulty Inlet Air Thermistor	Fault	Check resistance.	Replace thermistor if faulty.
	Incorrect Connection	Check connection.	Connect wiring correctly.
Faulty I.U. PCB		Replace I.U. PCB and check operation.	Replace I.U. PCB if faulty.

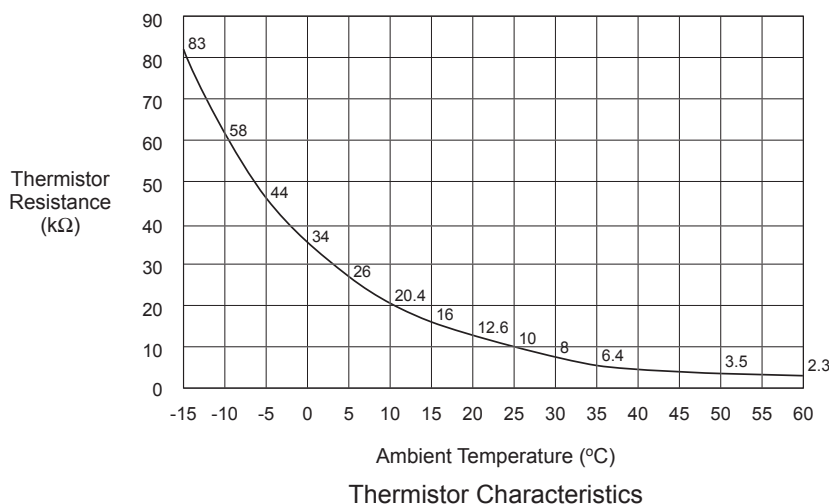

Indication of Outdoor Unit PCB
(Alarm Code 11 ~ 19)



Alarm Code
(11 ~ 19)

Indoor Unit No.
for Malfunction

NOTE:

This figure is applicable to the following thermistors.

1. Inlet Air Thermistor (THM1), 2. Liquid Pipe Thermistor (Freeze Protection) (THM3),
3. Gas Pipe Thermistor (THM5), 4. Outlet Air Thermistor (THM2)

Alarm Code	12	Abnormality of Thermistor for Indoor Unit Outlet Air Temperature (Outlet Air Thermistor)
------------	----	---

- The RUN indicator (Red) is flashing.
- The indoor unit number, the alarm code, the unit model code and the connected number of indoor units are displayed on LCD. Meanwhile, the indoor unit number and the alarm code are displayed on the 7-segment of outdoor unit PCB.

★ This alarm code is indicated when a short circuit (less than 0.24kΩ) or disconnection (more than 840kΩ) of the thermistor is detected during the heating or cooling operation. The operation is automatically restarted when the malfunction is removed.

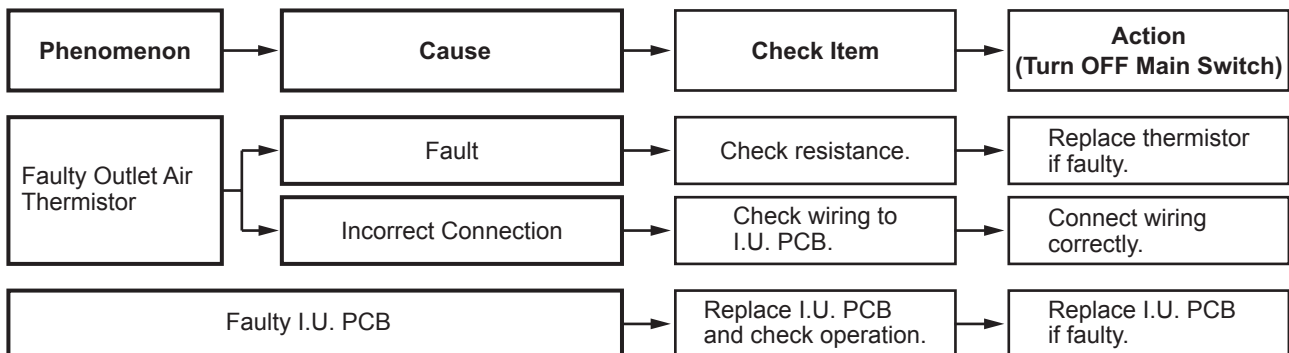
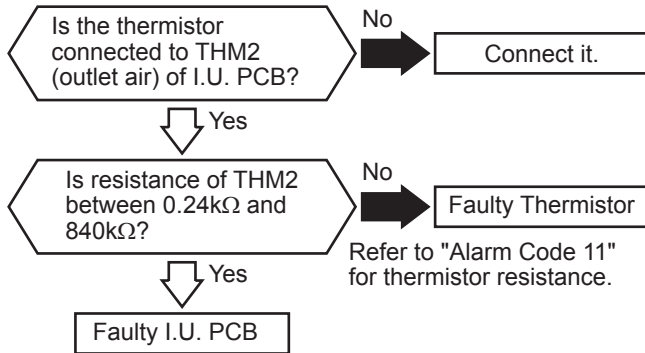

Alarm Code	13	Abnormality of Thermistor for Liquid Refrigerant Pipe Temperature at Indoor Unit Heat Exchanger (Freeze Protection Thermistor)
------------	----	--

- The RUN indicator (Red) is flashing.
- The indoor unit number, the alarm code, the unit model code and the connected number of indoor units are displayed on LCD. Meanwhile, the indoor unit number and the alarm code are displayed on the 7-segment of outdoor unit PCB.

★ This alarm code is indicated when a short circuit (less than 0.24kΩ) or disconnection (more than 840kΩ) of the thermistor is detected during the heating or cooling operation. The operation is automatically restarted when the malfunction is removed.

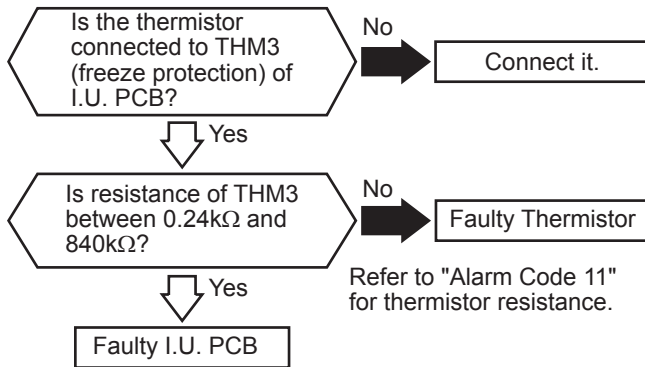

Phenomenon	Cause	Check Item	Action (Turn OFF Main Switch)
Faulty Freeze Protection Thermistor	Fault	Check resistance.	Replace thermistor if faulty.
	Incorrect Connection	Check wiring to I.U. PCB.	Connect wiring correctly.
Faulty I.U. PCB		Replace I.U. PCB and check operation.	Replace I.U. PCB if faulty.

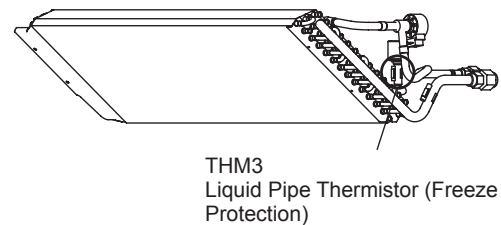
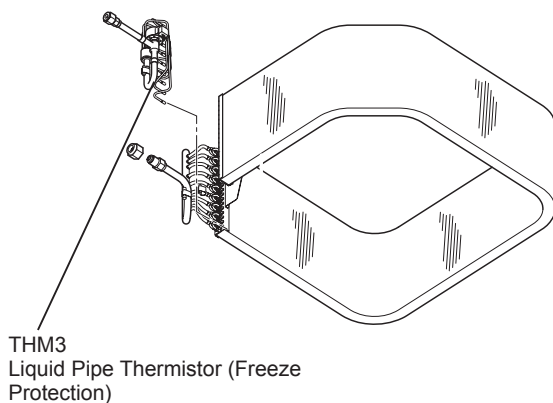

Alarm Code	14	Abnormality of Thermistor for Gas Refrigerant Pipe Temperature at Indoor Unit Heat Exchanger (Gas Pipe Thermistor)
------------	----	--

- The RUN indicator (Red) is flashing.
- The indoor unit number, the alarm code, the unit model code and the connected number of indoor units are displayed on LCD. Meanwhile, the indoor unit number and the alarm code are displayed on the 7-segment of outdoor unit PCB.

★ This alarm code is indicated when a short circuit (less than 0.24kΩ) or disconnection (more than 840kΩ) of the thermistor is detected during the heating ^{*1)} or cooling operation. The operation is automatically restarted when the malfunction is removed.

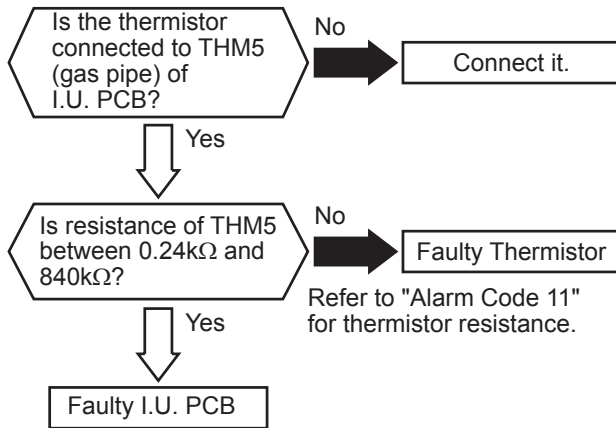

Phenomenon	Cause	Check Item	Action (Turn OFF Main Switch)
Faulty Thermistor for Indoor Unit Heat Exchanger Gas Pipe Temp.	Fault	Check resistance.	Replace thermistor if faulty.
	Incorrect Connection	Check wiring to I.U. PCB.	Connect wiring correctly.
Faulty I.U. PCB		Replace I.U. PCB and check operation.	Replace I.U. PCB if faulty.

*1): The heating operation is available only during the test run.

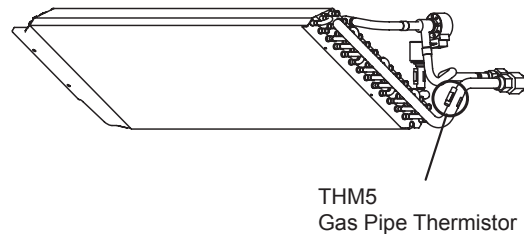
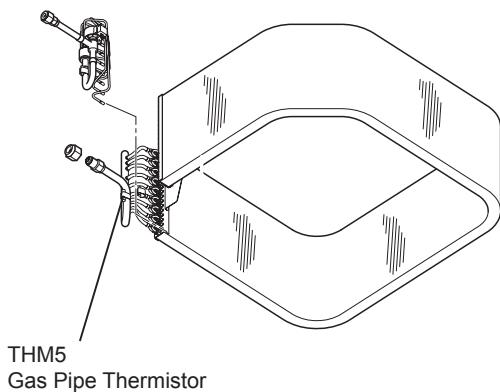

Alarm Code	19	Activation of Protection Device for Indoor Fan Motor (Indoor Unit with DC Motor)
------------	----	---

- The RUN indicator (Red) is flashing.
- The indoor unit number, the alarm code, the unit model code and the connected number of indoor units are displayed on LCD. Meanwhile, the indoor unit number and the alarm code are displayed on the 7-segment of outdoor unit PCB.

★ This alarm code is indicated when the indoor fan motor rotates at less than 70rpm for 5 seconds three times in 30 minutes during the operation.

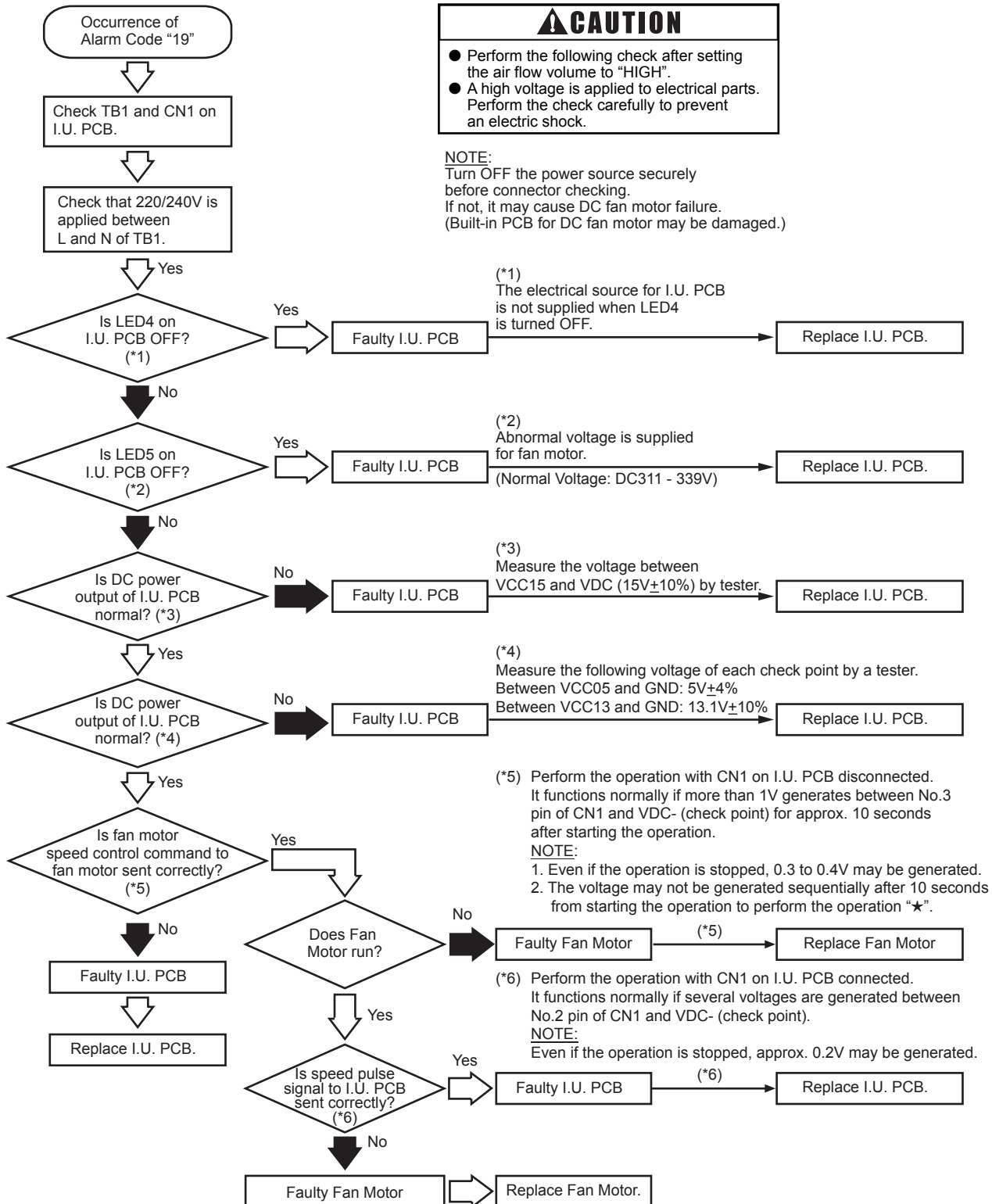

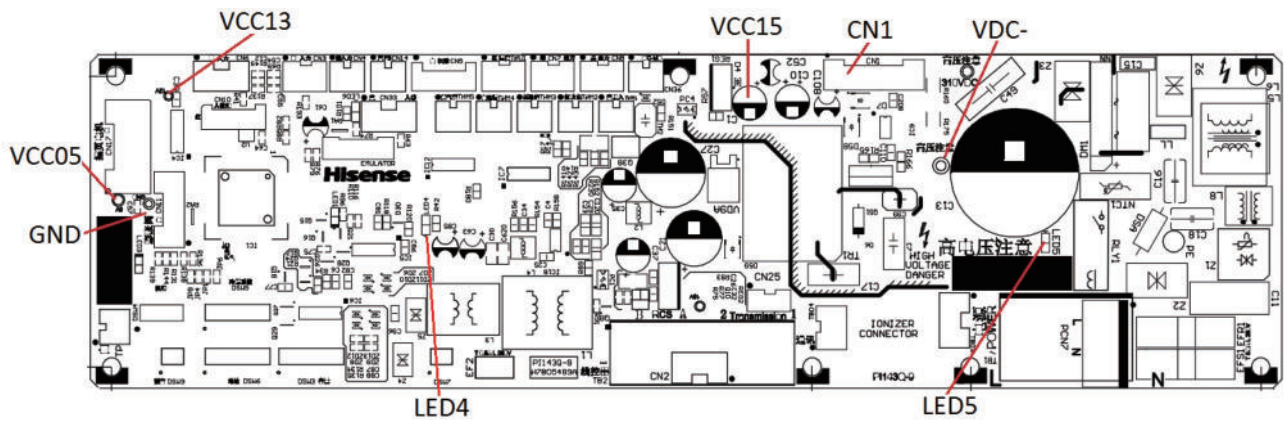

Alarm Code	19	Activation of Protection Device for Indoor Fan Motor (Indoor Unit with AC Motor)
------------	----	---

- The RUN indicator (Red) is flashing.
- The indoor unit number, the alarm code, the unit model code and the connected number of indoor units are displayed on LCD. Meanwhile, the indoor unit number and the alarm code are displayed on the 7-segment of outdoor unit PCB.

★ This alarm code is indicated when over approximately 1A is applied to the indoor unit fan motor.

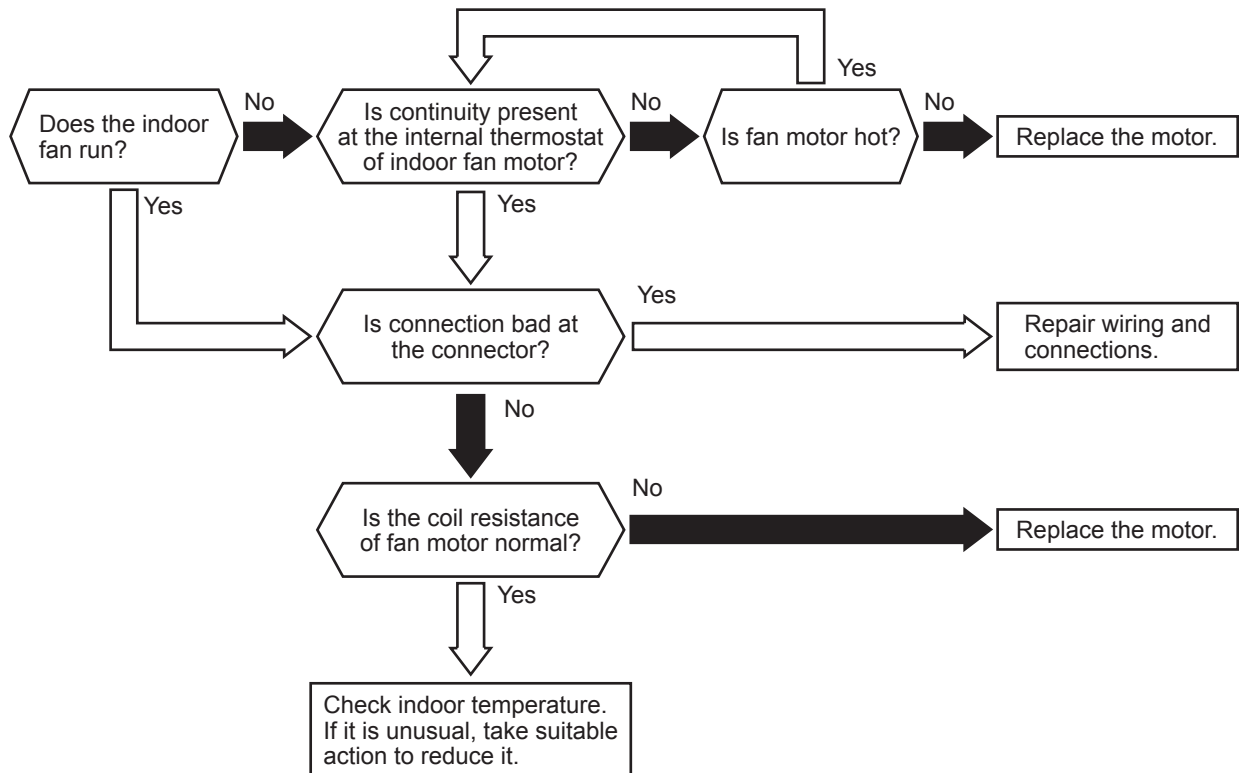

Phenomenon	Cause	Check Item	Action (Turn OFF Main Switch)	
Activation of Internal Thermostat for Indoor Unit Fan Motor	Faulty Indoor Unit Fan Motor	Measure coil resistance and insulation resistance.	Replace motor if faulty.	
	Faulty Internal Thermostat	Fault	Check continuity after fan motor temperature decreases to room temp.	Replace fan motor if no continuity.
		Insufficient Contacting	Measure resistance by tester.	Correct looseness. Replace connectors.
		Incorrect Connection	Check connections.	Repair connections.

Alarm Code	21	Abnormality of High Pressure Sensor for Outdoor Unit
------------	----	--

- The RUN indicator (Red) is flashing.
- The indoor unit number, the alarm code, the unit model code and the connected number of indoor units are displayed on LCD. Meanwhile, the indoor unit number and the alarm code are displayed on the 7-segment of outdoor unit PCB.

★ This alarm code is indicated when the pressure sensor voltage decreases to 0.1V or less or increases to 4.9V or more during running.

O.U. PCB: Outdoor Unit PCB

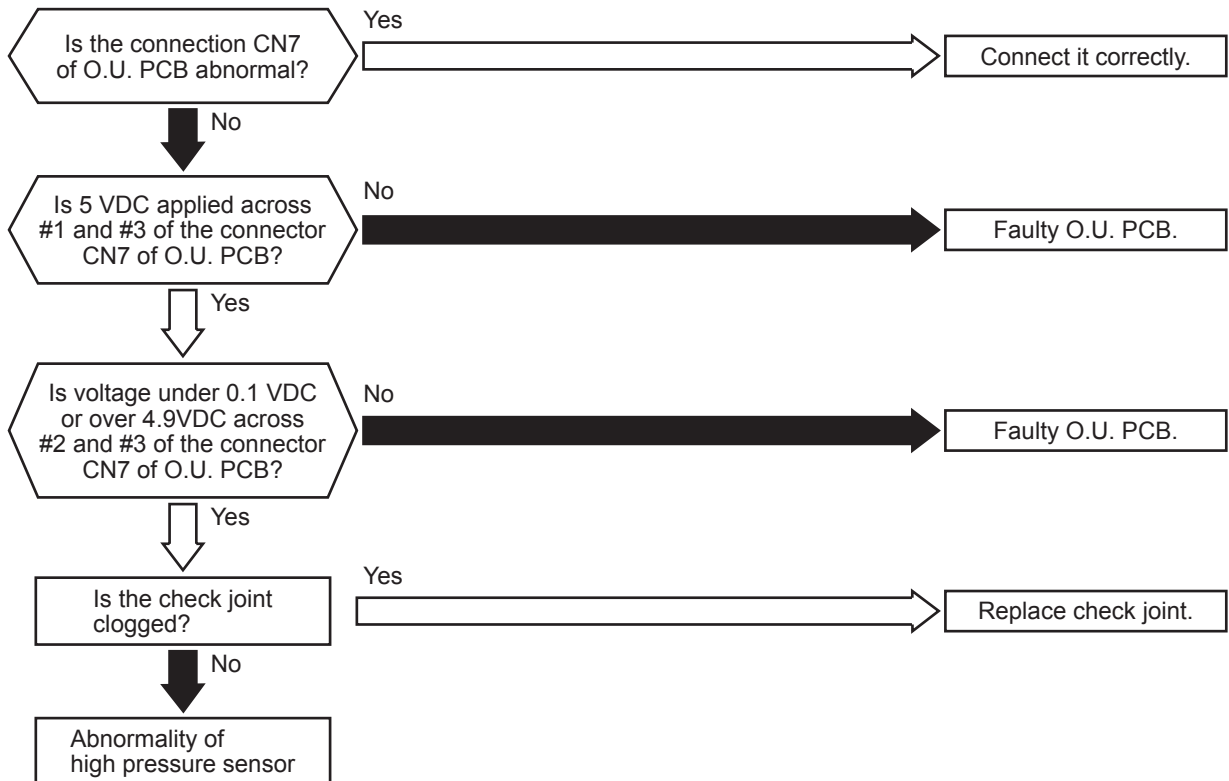

Phenomenon	Cause	Check Item	Action (Turn OFF Main Switch)
Faulty Top of Compressor Thermistor	Fault	Check resistance.	Replace thermistor if faulty.
	Incorrect Connection	Check wiring to O.U. PCB.	Repair wiring and connections.
Faulty O.U. PCB		Replace O.U. PCB and check operation.	Replace O.U. PCB if faulty.
Indicated Value of Pressure Value is Excessively High or Low	Malfunction of Pressure Sensor due to Faulty Check Joint	Check for clogging of check joint.	Replace check joint.

Alarm Code	22	Abnormality of Thermistor for Outdoor Air Temperature (Outdoor Unit Ambient Thermistor)
------------	----	--

- The RUN indicator (Red) is flashing.
- The indoor unit number, the alarm code, the unit model code and the connected number of indoor units are displayed on LCD. Meanwhile, the indoor unit number and the alarm code are displayed on the 7-segment of outdoor unit PCB.

★ This alarm code is indicated when a short circuit (less than 0.2kΩ) or disconnection (more than 500kΩ) of the thermistor is detected during the operation.

O.U. PCB: outdoor unit PCB

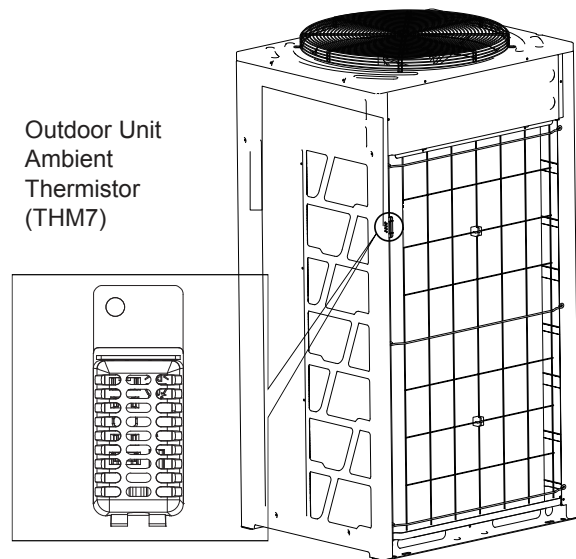
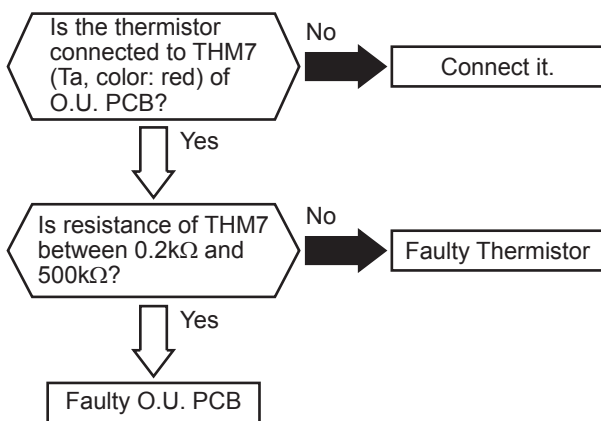

Phenomenon	Cause	Check Item	Action (Turn OFF Main Switch)
Faulty Thermistor for Outdoor Unit Ambient	Fault	Check resistance.	Replace thermistor if faulty.
	Incorrect Connection	Check wiring to O.U. PCB.	Repair wiring and connections.
Faulty O.U. PCB		Replace O.U. PCB and check operation.	Replace O.U. PCB if faulty.

Alarm Code	23	Abnormality of Thermistor for Discharge Gas Temperature on the Top of Compressor
------------	----	--

- The RUN indicator (Red) is flashing.
- The indoor unit number, the alarm code, the unit model code and the connected number of indoor units are displayed on LCD. Meanwhile, the indoor unit number and the alarm code are displayed on the 7-segment of outdoor unit PCB. (For the combination of outdoor units, the alarm code is displayed on PCB of outdoor unit A.) Additionally for the outdoor unit number and compressor number with abnormal thermistor, check the alarm code history.

★ This alarm code is indicated when a short circuit (less than 0.9kΩ) for a second or disconnection (more than 5946kΩ) of the thermistor is detected during the operation.

O.U. PCB: outdoor unit PCB

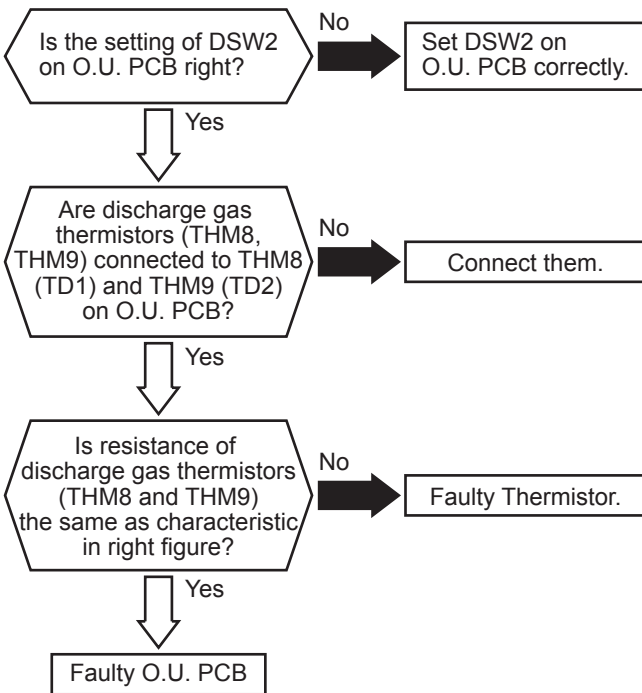

Model	Thermistor	
	Td1 (THM8)	Td2 (THM9)
Single Comp.	○	-
Dual Comp.	○	○

In the case of the combination of outdoor units, each outdoor unit detect abnormality.

Characteristics of Thermistor

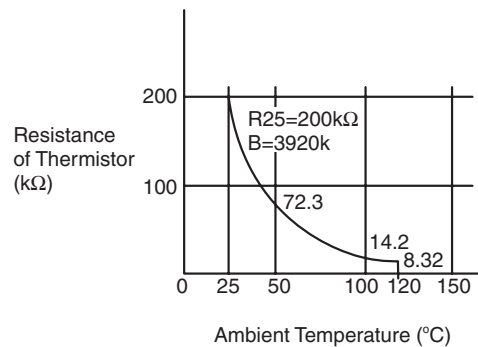

Phenomenon	Cause	Check Item	Action (Turn OFF Main Switch)
Faulty Discharge Gas Thermistor	Fault	Check resistance.	Replace thermistor if faulty.
	Incorrect Connection	Check wiring to O.U. PCB.	Repair wiring and connections.
Faulty O.U. PCB		Replace O.U. PCB and check operation.	Replace O.U. PCB if faulty.
Incorrect Setting of DSW2 on O.U. PCB		Check setting of DSW2 on O.U. PCB.	Correctly set DSW2 on O.U. PCB.

Alarm Code	24	Abnormality of Thermistor for Outdoor Unit Heat Exchanger Liquid Pipe (Te1/Te2/Tchg/Tsc)
------------	----	--

- The RUN indicator (Red) is flashing.
- The indoor unit number, the alarm code, the unit model code and the connected number of indoor units are displayed on LCD. Meanwhile, the indoor unit number and the alarm code are displayed on the 7-segment of outdoor unit PCB. (For the combination of outdoor units, the alarm code is displayed on PCB of outdoor unit A.) Additionally for the outdoor unit number and compressor number with abnormal thermistor, check the alarm code history.

★ This alarm code is indicated when a short circuit (less than 0.24kΩ) or disconnection (more than 840kΩ) of the thermistor is detected continuously for 8 minutes during the operation.

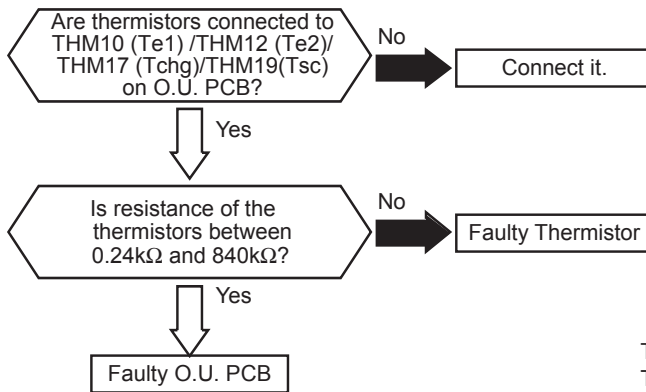

Model	Thermistor	
	Te1 (THM10)	Te2 (THM12)
Single HEX.	○	○

In the case of the combination of outdoor units, each outdoor unit detect abnormality.

Te1: thermistor for outdoor liquid pipe
 Te2: thermistor for main liquid pipe
 Tchg: thermistor for sub cooling main line
 Tsc: temperature at refrigerant radiator
 O.U. PCB: outdoor unit PCB
 HEX. : heat exchanger

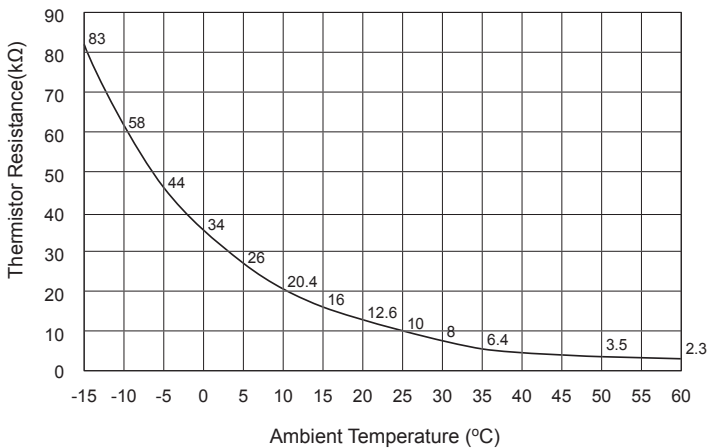

NOTE:

This figure is applicable to the following thermistors.

1. Ambient Temperature Thermistor (THM7),
2. Evaporation Liquid Line Thermistor (THM10),
3. Evaporation Main Liquid Line Thermistor (THM12),
4. Evaporation Gas Line Thermistor (THM11),
5. Sub Cooling Main Line Thermistor (THM17),
6. Sub Cooling Bypass Line Thermistor (THM23)
7. Inlet Pipe of The Sub Cooler Thermistor (THM19)

Thermistor Characteristics

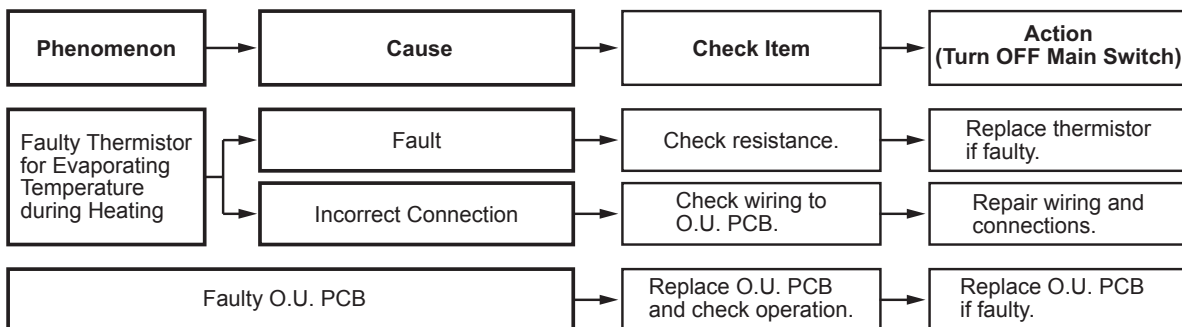

Alarm Code	25	Abnormality of Thermistor for Outdoor Unit Heat Exchanger Gas Pipe (Tg/Tbg)
------------	----	---

- The RUN indicator (Red) is flashing.
- The indoor unit number, the alarm code, the unit model code and the connected number of indoor units are displayed on LCD. Meanwhile, the indoor unit number and the alarm code are displayed on the 7-segment of outdoor unit PCB. (For the combination of outdoor units, the alarm code is displayed on PCB of outdoor unit A.) Additionally for the outdoor unit number and compressor number with abnormal thermistor, check the alarm code history.

★ This alarm code is indicated when a short circuit (less than 0.24kΩ) or disconnection (more than 840kΩ) of the thermistor is detected continuously for 8 minutes during the operation.

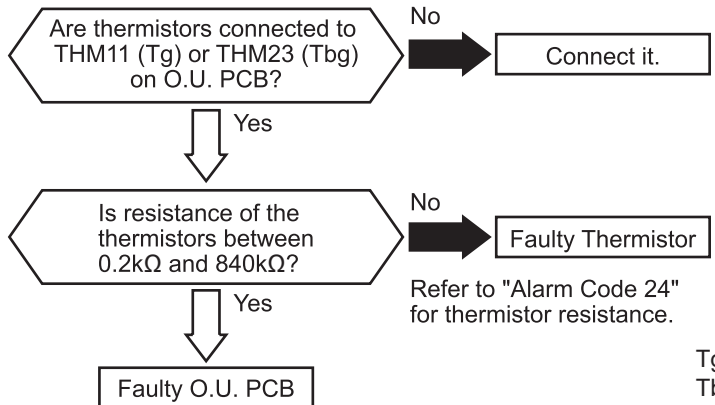

Tg: thermistor for outdoor gas pipe
 Tbg: thermistor for super cooling bypass line
 O.U. PCB: outdoor unit PCB

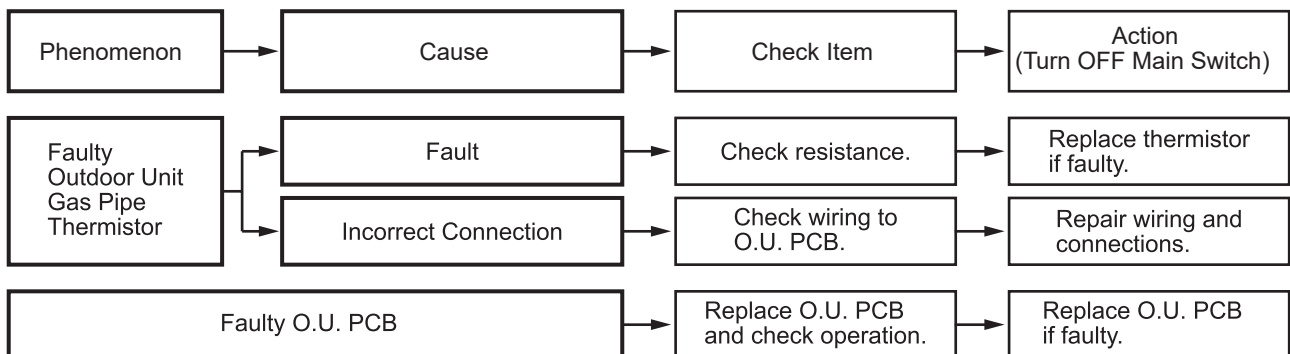

Alarm Code	29	Abnormality of Low Pressure Sensor for Outdoor Unit
------------	----	---

- The RUN indicator (Red) is flashing.
- The indoor unit number, the alarm code, the unit model code and the connected number of indoor units are displayed on LCD. Meanwhile, the indoor unit number and the alarm code are displayed on the 7-segment of outdoor unit PCB.

★ This alarm code is indicated when the pressure sensor voltage decreases to 0.1V or less or increases to 4.9V or more during running.

O.U. PCB: outdoor unit PCB

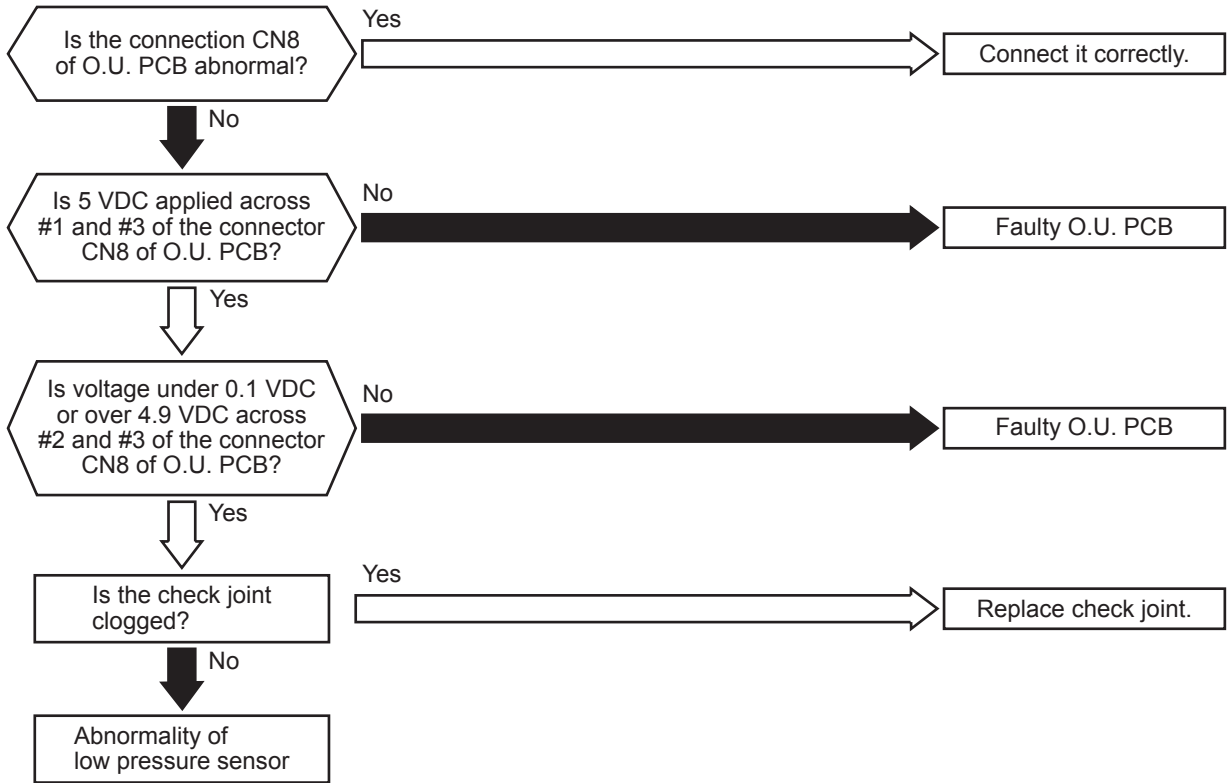

Phenomenon	Cause	Check Item	Action (Turn OFF Main Switch)
Faulty Low Pressure Sensor	Fault	Check output voltage is correct.	Replace pressure sensor if faulty.
	Incorrect Connection	Check wiring to O.U. PCB.	Repair wiring and connections.
Faulty O.U. PCB		Replace O.U. PCB and check operation.	Replace O.U. PCB if faulty.
Indicated Value of Pressure Value is Excessively High or Low	Malfunction of Pressure Sensor due to Faulty Check Joint	Check for clogging of check joint.	Replace check joint.

Alarm Code	31	Incorrect Capacity Setting of Indoor Unit and Outdoor Unit
------------	----	--

- The RUN indicator (Red) is flashing.
- The indoor unit number, the alarm code, the unit model code and the connected number of indoor units are displayed on LCD. Meanwhile, the indoor unit number and the alarm code are displayed on the 7-segment of outdoor unit PCB.

★ This alarm code is indicated when the capacity setting DIP switch, DSW2 on the outdoor unit PCB, is not set (all the settings from #1 to #6 are OFF) or set incorrectly.

★ This alarm code is indicated when the total indoor unit capacity is smaller than 50% or greater than 150% of the combined outdoor unit capacity. This alarm code also can be triggered when Water Module capacity is greater than 100% of the combined outdoor unit capacity or improper function setting of “H4” on the outdoor unit PCB for Water Module application.

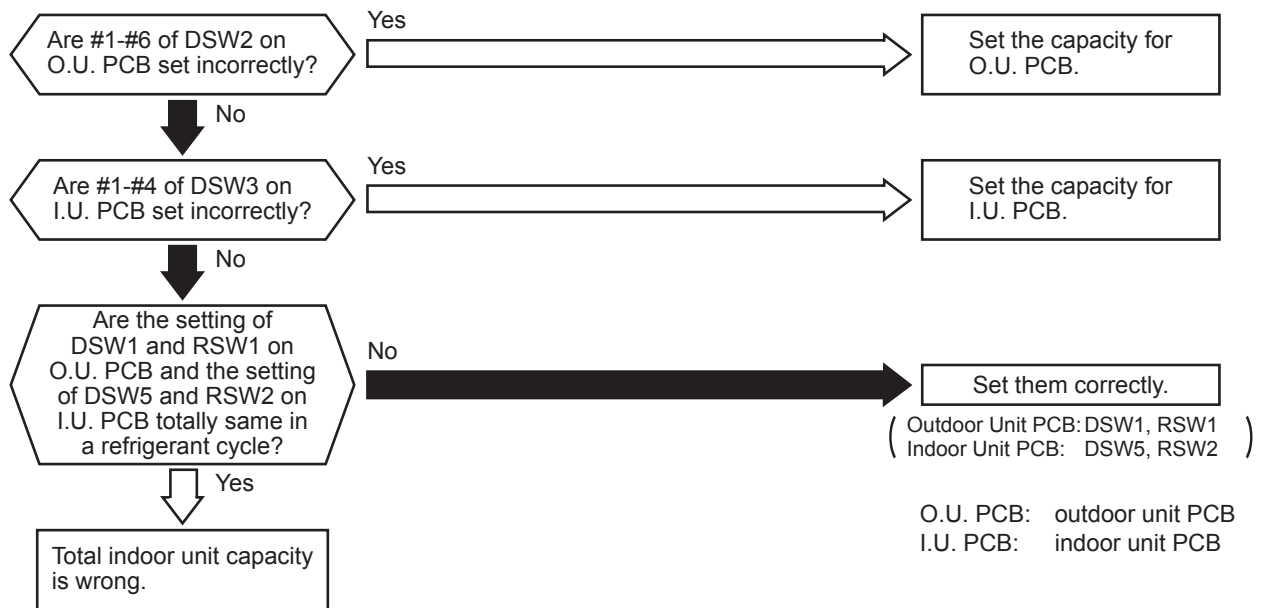

Phenomenon	Cause	Check Item	Action (Turn OFF Main Switch)
Incorrect Capacity Setting of Indoor Unit		Check combination of indoor units and capacity setting on I.U. PCB.	Correctly set dip switch, DSW3.
Incorrect Capacity Setting of Outdoor Unit		Check capacity setting on O.U. PCB.	Correctly set dip switch, DSW2.
Total Indoor Unit Capacity Connected to the Outdoor Unit is Beyond Permissible Range		Check outdoor unit model by calculating total indoor units capacity.	Ensure that total indoor unit capacity is from 50% to 150%.
Refrigeration Cycle Setting of Outdoor Unit and Indoor Unit is Different		Check refrigeration cycle setting on O.U. PCB and I.U. PCB.	Set them correctly.

Alarm Code	31	Abnormal Transmitting between Outdoor Units
------------	----	---

- The RUN indicator (Red) is flashing.
- The indoor unit number, the alarm code, the unit model code and the connected number of indoor units are displayed on LCD. Meanwhile, the indoor unit number and the alarm code are displayed on the 7-segment of outdoor unit PCB.

★ This alarm code is indicated when the following conditions occur after normal transmitting between outdoor units is performed;

- Abnormality continues for 30 seconds.
- Abnormality continues for 30 seconds even after micro-computer reset (automatic).

O.U. PCB: outdoor unit PCB

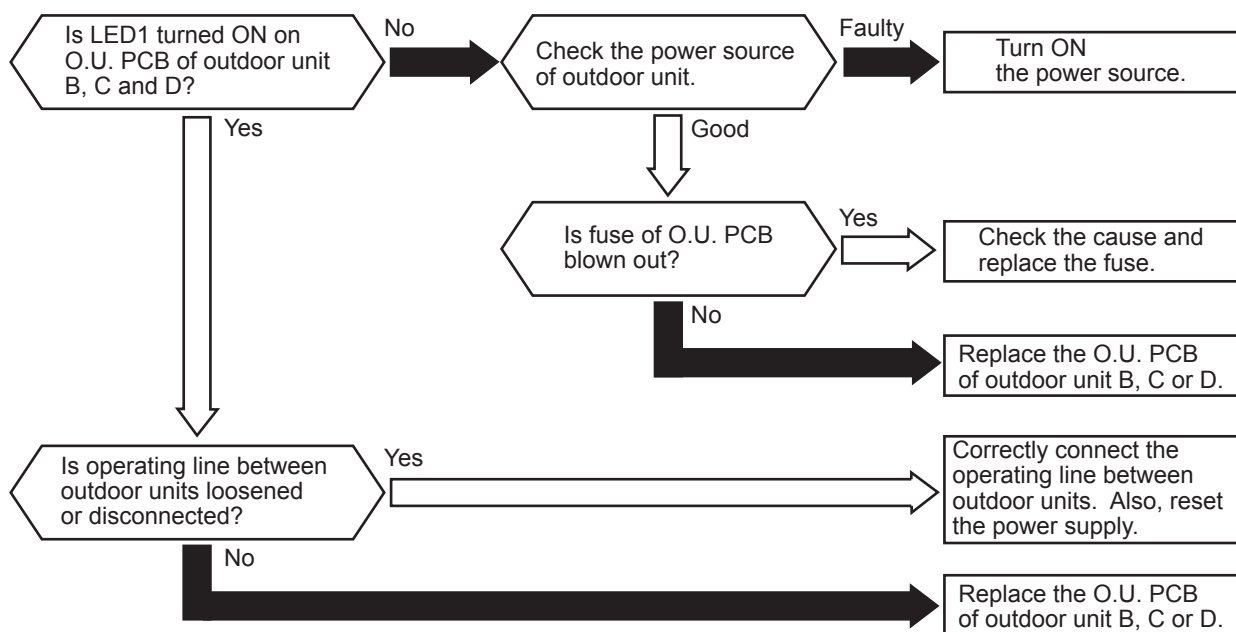

Outdoor Unit

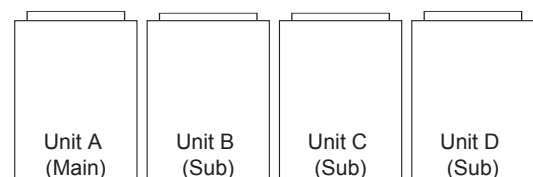

Alarm Code	35	Incorrect Indoor Unit No. Setting
------------	----	-----------------------------------

- The RUN indicator (Red) is flashing.
- The indoor unit number, the alarm code, the unit model code and the connected number of indoor units are displayed on LCD. Meanwhile, the indoor unit number and the alarm code are displayed on the 7-segment of outdoor unit PCB.

★ This alarm code is indicated 5 minutes after power is supplied to the outdoor unit when the indoor unit No. connected to the outdoor unit is duplicated by setting of DSW6 and RSW1.

NOTE:

- In the case of H-NET systems, this alarm code is indicated when DSW1 and RSW1 of PCB1 of the outdoor unit and DSW5 and RSW2 of the PCB of the indoor unit are incorrectly set. In this case, set them properly after turning OFF the main power switch and turn ON again the main power switch.
- When the setting of the refrigerant cycle number of the outdoor unit (H-NET) and that of the outdoor unit (H-NET) is duplicated, alarm code "35" can be ON and OFF repeatedly.

Alarm Code	36	Incorrect Indoor Unit Combination
------------	----	-----------------------------------

- The RUN indicator (Red) is flashing.
- The indoor unit number, the alarm code, the unit model code and the connected number of indoor units are displayed on LCD. Meanwhile, the indoor unit number and the alarm code are displayed on the 7-segment of outdoor unit PCB.

★ This alarm code is indicated when the indoor unit connected to the outdoor unit is for other refrigerants (R22 or R407C).

Alarm Code	38	Abnormality of Picking up Circuit for Protection in Outdoor Unit
------------	----	--

- The RUN indicator (Red) is flashing.
- The indoor unit number, the alarm code, the unit model code and the connected number of indoor units are displayed on LCD. Meanwhile, the indoor unit number and the alarm code are displayed on the 7-segment of outdoor unit PCB.

★ This alarm code is indicated when AC 220V or 240V is not detected in A* during inverter compressor stoppage.

O.U. PCB: outdoor unit PCB

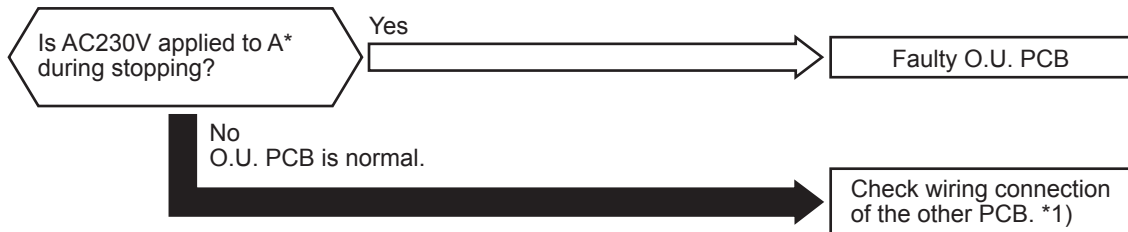

Power Supply	A*
380-415V/50Hz 380/60Hz	Between terminal #3 of PCN2, PCN16 and faston terminal "N1" on O.U. PCB

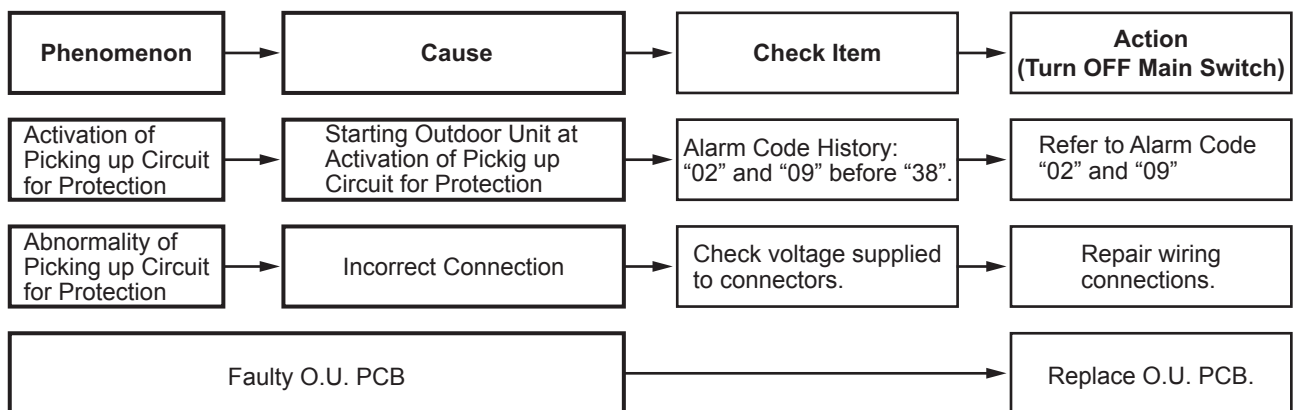

*1): This alarm code may be indicated when the high pressure switch (PSH) is connected incorrectly or fails (open fault). The item for alarm code 02 should be checked as well.

*2): Especially, check the wiring connection for PCN2 and PCN16 on O.U. PCB.

Alarm Code	3A	Abnormality of Outdoor Unit Capacity
------------	----	--------------------------------------

- The RUN indicator (Red) is flashing.
- The indoor unit number, the alarm code, the unit model code and the connected number of indoor units are displayed on LCD, or the indoor unit number and the alarm code are displayed on the 7-segment of outdoor unit PCB.

★ This alarm code is indicated when the total capacity of outdoor unit connected to the transmission terminal between outdoor units exceeds maximum total power allowed.

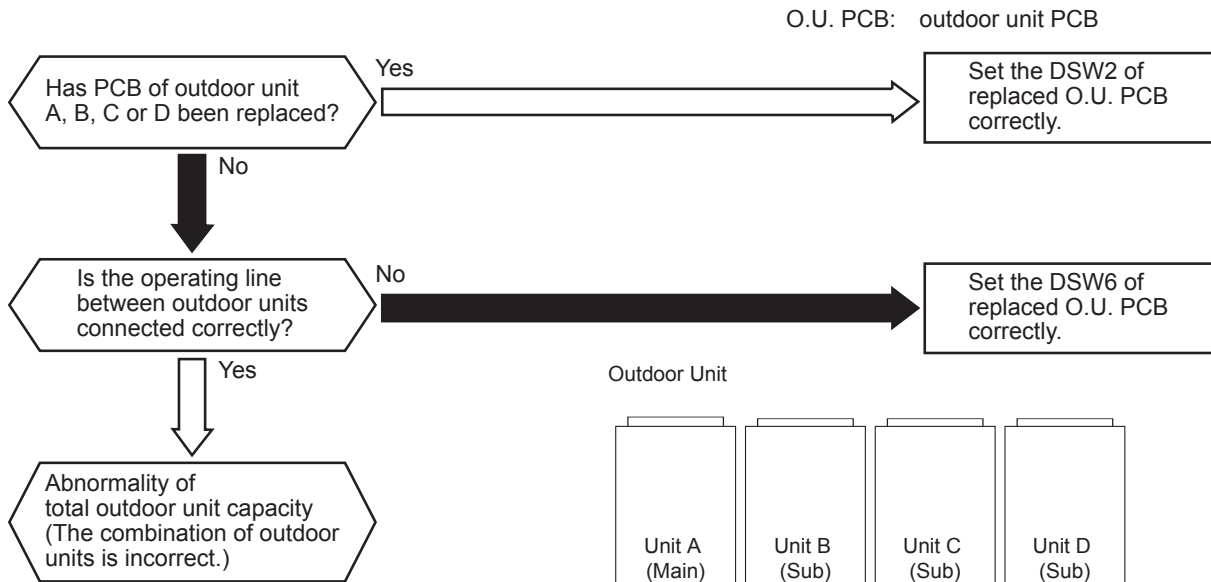

Alarm Code	3B	Incorrect Setting of Outdoor Unit Model Combination or Voltage
------------	----	--

- The RUN indicator (Red) is flashing.
- The indoor unit number, the alarm code, the unit model code and the connected number of indoor units are displayed on LCD, or the indoor unit number and the alarm code are displayed on the 7-segment of outdoor unit PCB.

★ This alarm code is indicated when the model setting for outdoor unit connected to the transmission terminal between outdoor units is incorrect.

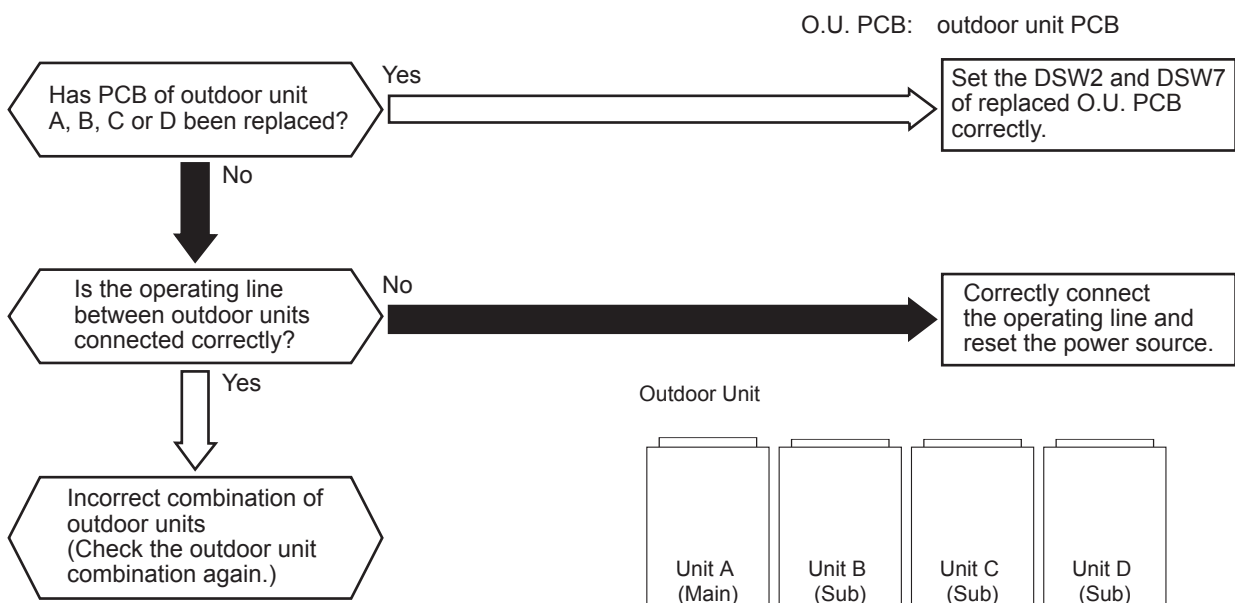

Alarm Code	3d	Abnormality Transmitting between Main Unit and Sub Unit(s)
------------	----	--

- The RUN indicator (Red) is flashing.
- The indoor unit number, the alarm code, the unit model code and the connected number of indoor units are displayed on LCD, or the indoor unit number and the alarm code are displayed on the 7-segment of outdoor unit PCB.

★ For the combination of outdoor units, this alarm code is indicated when transmission to outdoor unit B, C or D is NOT provided for 30 seconds. (Alarm code “31” will be indicated when transmission to all the outdoor units connected to the transmission terminal between outdoor units is NOT provided.)

O.U. PCB: outdoor unit PCB

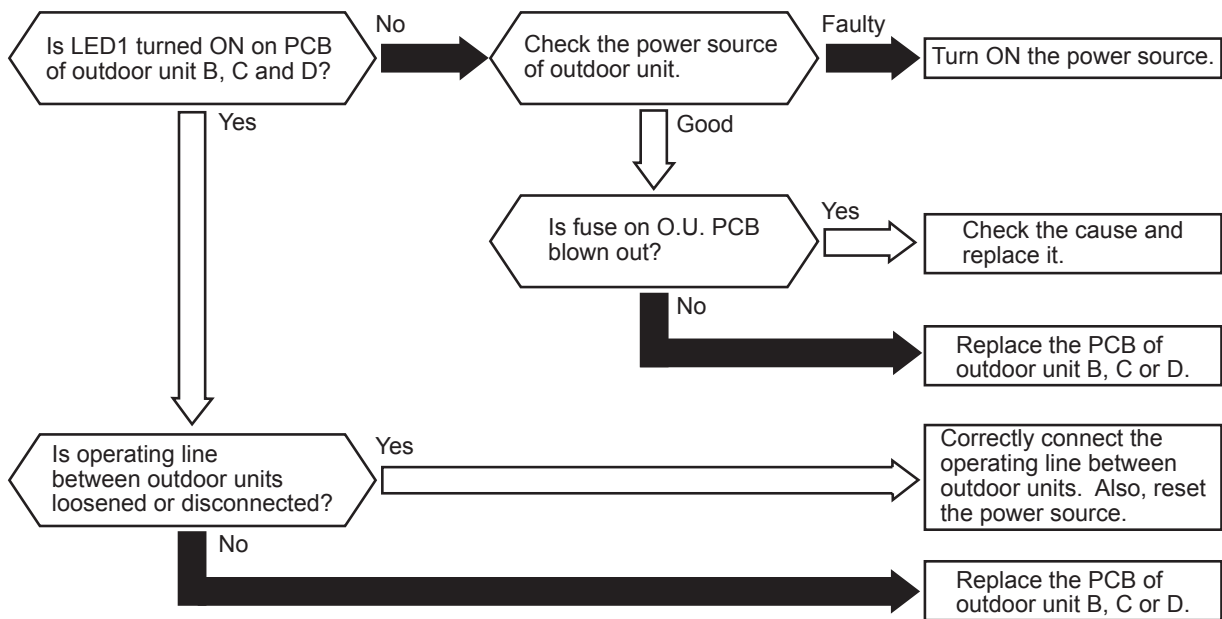

Outdoor Unit

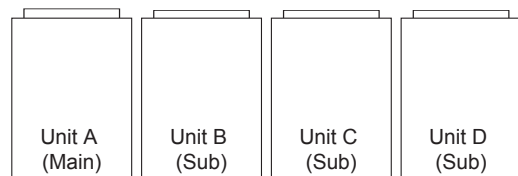

Alarm Code	43	Activation of Low Compression Ratio Protection Device
------------	----	---

- The RUN indicator (Red) is flashing.
- The indoor unit number, the alarm code, the unit model code and the connected number of indoor units are displayed on LCD. Meanwhile, the indoor unit number and the alarm code are displayed on the 7-segment of outdoor unit PCB.

★ This alarm code is indicated when the following condition occurs more than twice in 30 minutes.
 A compression ratio $\epsilon = \{(Pd + 0.1) / (Ps + 0.06)\}$, calculated from a discharge pressure (Pd MPa) and suction pressure (Ps MPa) is lower than 1.5 for 2 minutes.

O.U. PCB: outdoor unit PCB

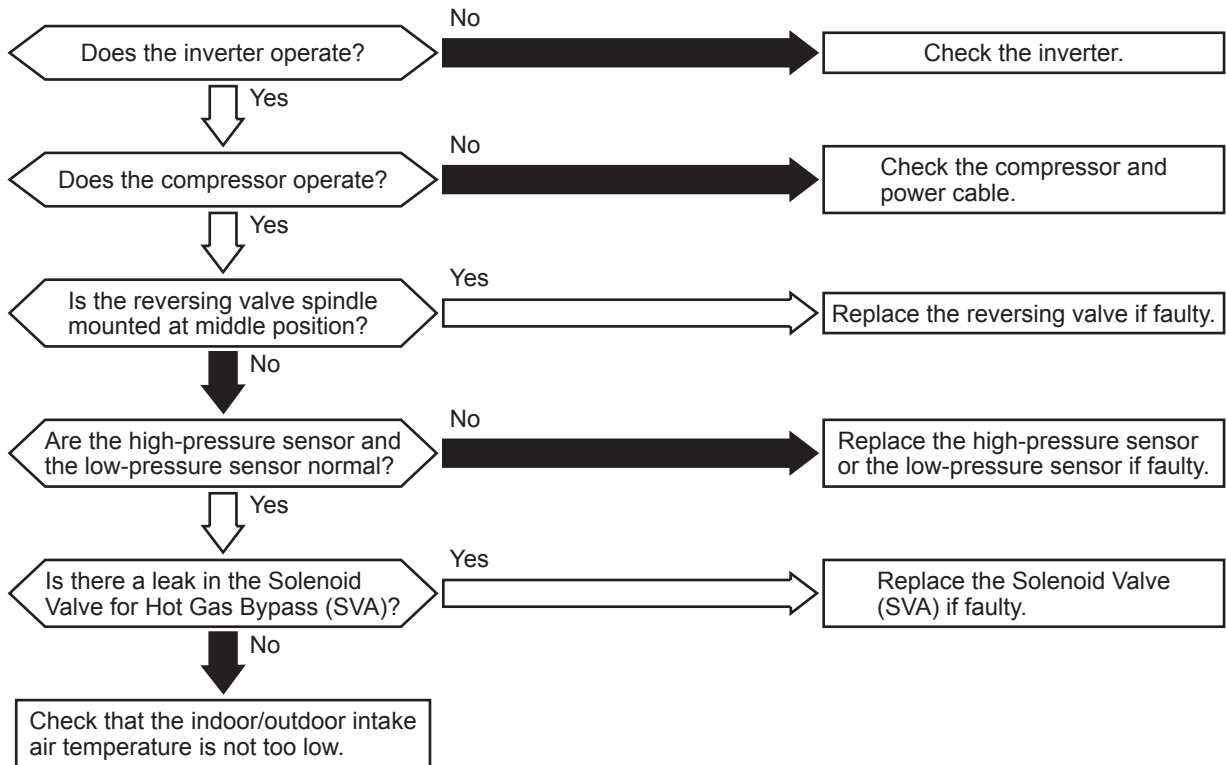

Phenomenon	Cause	Check Item	Action (Turn OFF Main Switch)
Excessively Low Compression Ratio	Inverter is not Functioning	Check inverter.	Repair faulty part.
	Compressor is not Operating	Check compressor.	Replace comp. if faulty.
	Valve Stoppage at Middle Position of Reversing Valve	Measure suction pipe temp. of reversing valve.	Replace reversing valve if faulty.
	Abnormality of High or Low Pressure Sensor	Check connector for O.U. PCB, power source and pressure indication.	Replace sensor if faulty.
	Excessively Low Indoor Intake Air Temperature	Check indoor unit and outdoor unit air temp. thermistor.	Replace thermistor if faulty.
	Leakage from Solenoid Valve (SVA)	Check Solenoid Valve.	Replace SVA if leakage occurs.

Alarm Code	44	Activation of Low Pressure Increase Protection Device
------------	----	---

- The RUN indicator (Red) is flashing.
- The indoor unit number, the alarm code, the unit model code and the connected number of indoor units are displayed on LCD. Meanwhile, the indoor unit number and the alarm code are displayed on the 7-segment of outdoor unit PCB.

★ For When the suction pressure (Ps) continues to be higher than Ps_max (1.8 Tamin>44°C, 1.4 Tamin≤44°C) for more than one minute, all the compressors stop and then retry the operation after 3 minutes.
 This alarm code is indicated when this occurs twice more within the next 30 minutes.

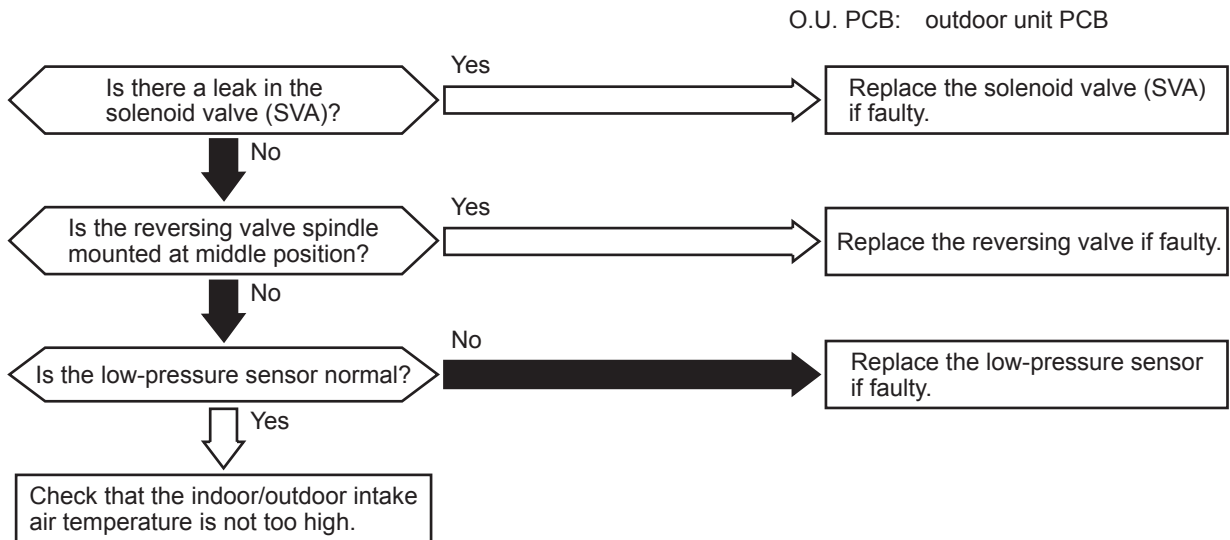

Phenomenon	Cause	Check Item	Action (Turn OFF Main Switch)
Excessively Low Suction Pressure	Leakage of Solenoid Valve (SVA)	Check outlet pipe temp. of solenoid valve (SVA).	Check connecting wires. Replace solenoid valve (SVA) if faulty.
	Valve Stoppage at Middle Position of Reversing Valve	Measure suction gas pipe temp. of reversing valve.	Replace reversing valve if faulty.
	Abnormal Suction Pressure Sensor	Check connectors of O.U. PCB and power source.	Replace sensor if faulty.
	Excessively High Indoor Unit and Outdoor Unit Suction Air Temperature	Check indoor unit and outdoor unit suction air temp. thermistor.	Replace thermistor if faulty.

Alarm Code	45	Activation of High Pressure Increase Protection Device
------------	----	--

- The RUN indicator (Red) is flashing.
- The indoor unit number, the alarm code, the unit model code and the connected number of indoor units are displayed on LCD. Meanwhile, the indoor unit number and the alarm code are displayed on the 7-segment of outdoor unit PCB.

★ For When the suction pressure (Ps) continues to be higher than 1.6MPa for more than one minute, all the compressors stop and then retry the operation after 3 minutes.
 This alarm code is indicated when this occurs twice more within the next 30 minutes.

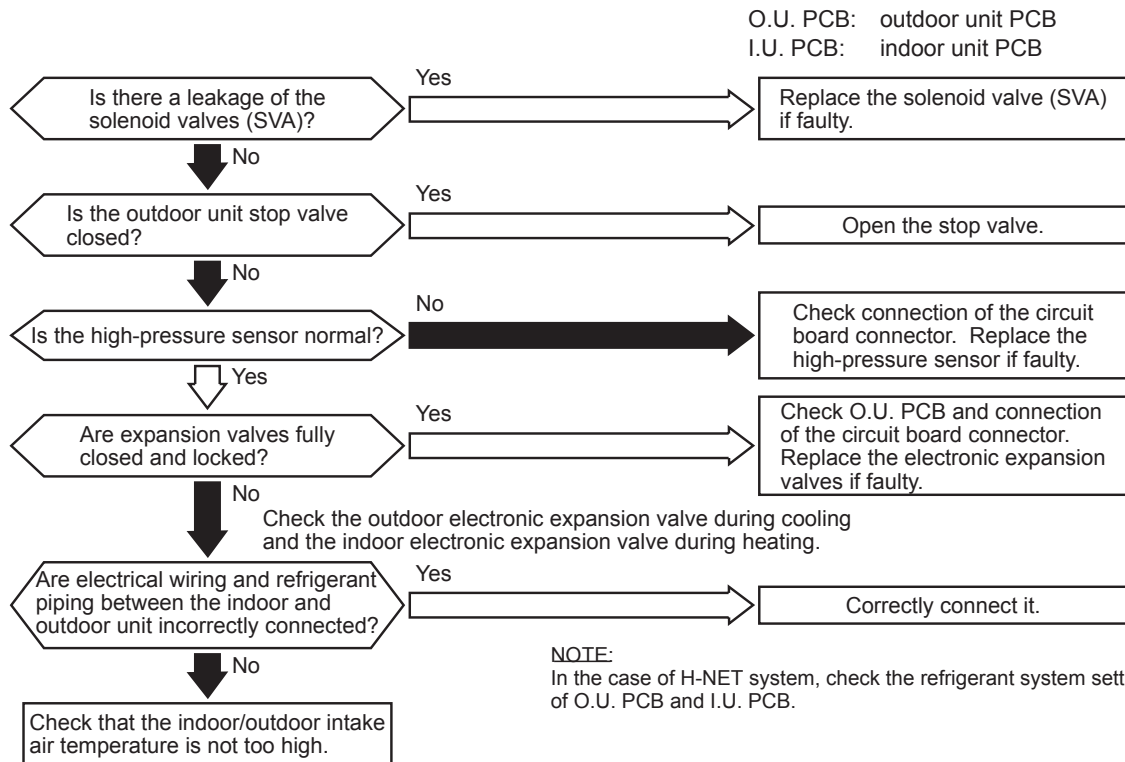

NOTE:
 In the case of H-NET system, check the refrigerant system setting of O.U. PCB and I.U. PCB.

Phenomenon	Cause	Check Item	Action (Turn OFF Main Switch)
Excessively High Discharge Pressure	Leakage of Solenoid Valve (SVA)	Check outlet temp. of solenoid valve (SVA).	Check connection. Replace solenoid valve (SVA) if faulty.
	Closed Stop Valve	Check stop valve.	Open stop valve.
	Abnormal High Pressure Sensor	Check connectors for O.U. PCB.	Replace pressure sensor if faulty.
	Excessively High Indoor Unit and Outdoor Unit Inlet Air Temp.	Check thermistor for indoor unit and outdoor unit inlet air temp.	Replace thermistor if faulty.
	Incorrect Connection between Indoor Unit and Outdoor Unit	Check electrical system and ref. cycle.	Correctly connect them.
	Locked Expansion Valve with Fully Closed	Check connector for O.U. PCB.	Repair connector for O.U. PCB or expansion valve. Replace it if faulty.
Stoppage of Indoor Fan <Wall Type 1.0 to 3.0HP Only>	Melted Fuses	Check continuity of fuses.	Replace fuses.
	Faulty I.U. PCB	Replace I.U. PCB and check operation.	Replace I.U. PCB if faulty.

Alarm Code	46	Activation of High Pressure Decrease Protection Device
------------	----	--

- The RUN indicator (Red) is flashing.
- The indoor unit number, the alarm code, the unit model code and the connected number of indoor units are displayed on LCD. Meanwhile, the indoor unit number and the alarm code are displayed on the 7-segment of outdoor unit PCB.

★ For When the suction pressure (Ps) continues to be higher than 1.6MPa for more than one minute, all the compressors stop and then retry the operation after 3 minutes.
This alarm code is indicated when this occurs twice more within the next 30 minutes.

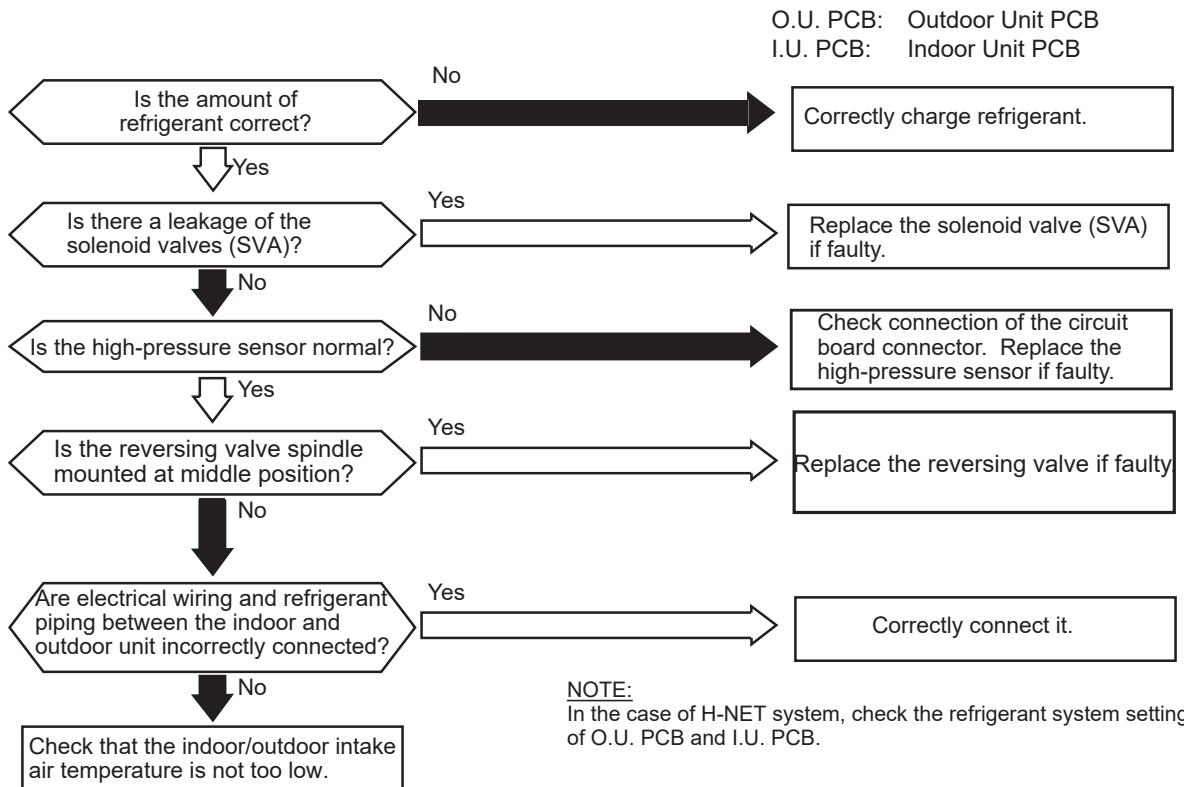

Phenomenon	Cause	Check Item	Action (Turn OFF Main Switch)
Excessively Low Discharge Pressure	Shortage of Ref.	Check charged ref. volume or check for leakage.	Repair leakage and correctly charge.
	Leakage of Solenoid Valve (SVA)	Check Solenoid Valve.	Replace SVA if leakage occurs.
	Abnormal High Pressure Sensor	Check connectors for O.U. PCB.	Replace pressure sensor if faulty.
	Valve Stoppage at Middle Position of Reversing Valve	Measure suction pipe temp. of reversing valve.	Replace reversing valve if faulty.
	Incorrect Connection between Indoor Unit and Outdoor Unit	Check electrical system and ref. cycle.	Correctly connect them.
	Excessively Low Indoor/outdoor Intake Air Temperature	Check indoor unit and outdoor unit air temp. thermistor.	Replace thermistor if faulty.

Alarm Code	47	Activation of Low Pressure Decrease Protection Device (Vacuum Operation Protection)
------------	----	--

- The RUN indicator (Red) is flashing.
- The indoor unit number, the alarm code, the unit model code and the connected number of indoor units are displayed on LCD. Meanwhile, the indoor unit number and the alarm code are displayed on the 7-segment of outdoor unit PCB.

★ This alarm code is indicated when a suction pressure (Ps) is lower than 0.09MPa for over 12 minutes and the same condition occurs twice or more within one hour.

O.U. PCB: outdoor unit PCB
I.U. PCB: indoor unit PCB

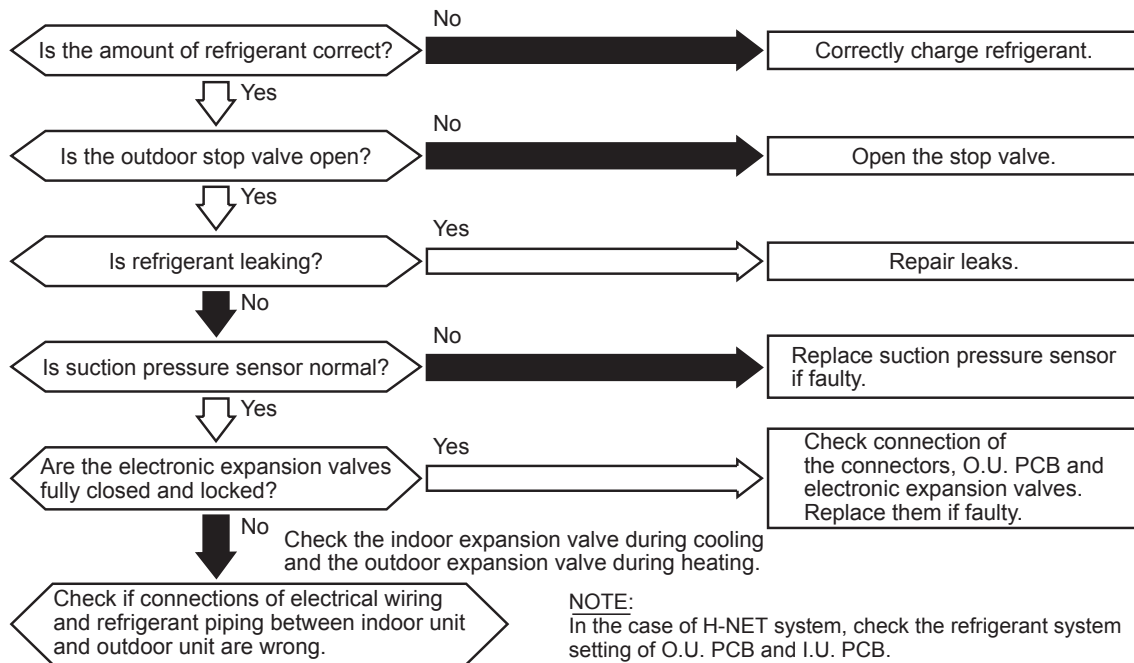

NOTE:
In the case of H-NET system, check the refrigerant system setting of O.U. PCB and I.U. PCB.

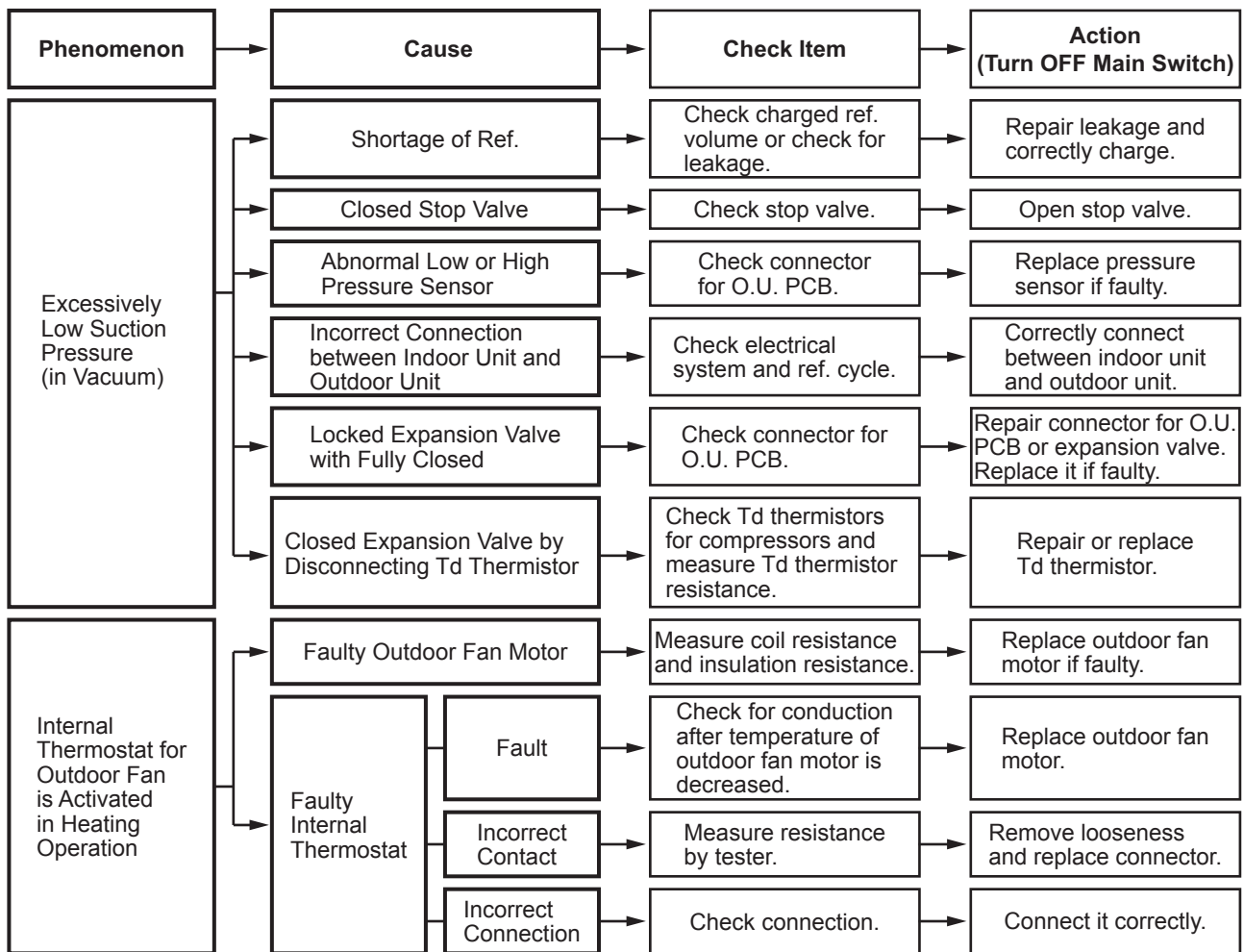

Alarm Code	48	Activation of Inverter Overcurrent Protection Device (1)
------------	----	--

- The RUN indicator (Red) is flashing.
- The indoor unit number, the alarm code, the unit model code and the connected number of indoor units are displayed on LCD. Meanwhile, the indoor unit number and the alarm code are displayed on the 7-segment of outdoor unit PCB.

★ This alarm code is indicated when inverter electronic thermal protection is activated six times within 30 minutes. (Retry operation is performed up to the occurrence of five times.)

Conditions of Activation:

- (1) Inverter current with 105% of the rated current runs for 30 seconds continuously.
- (2) Inverter current runs intermittently and the accumulated time reaches up to 3 minutes, in 10 minutes.

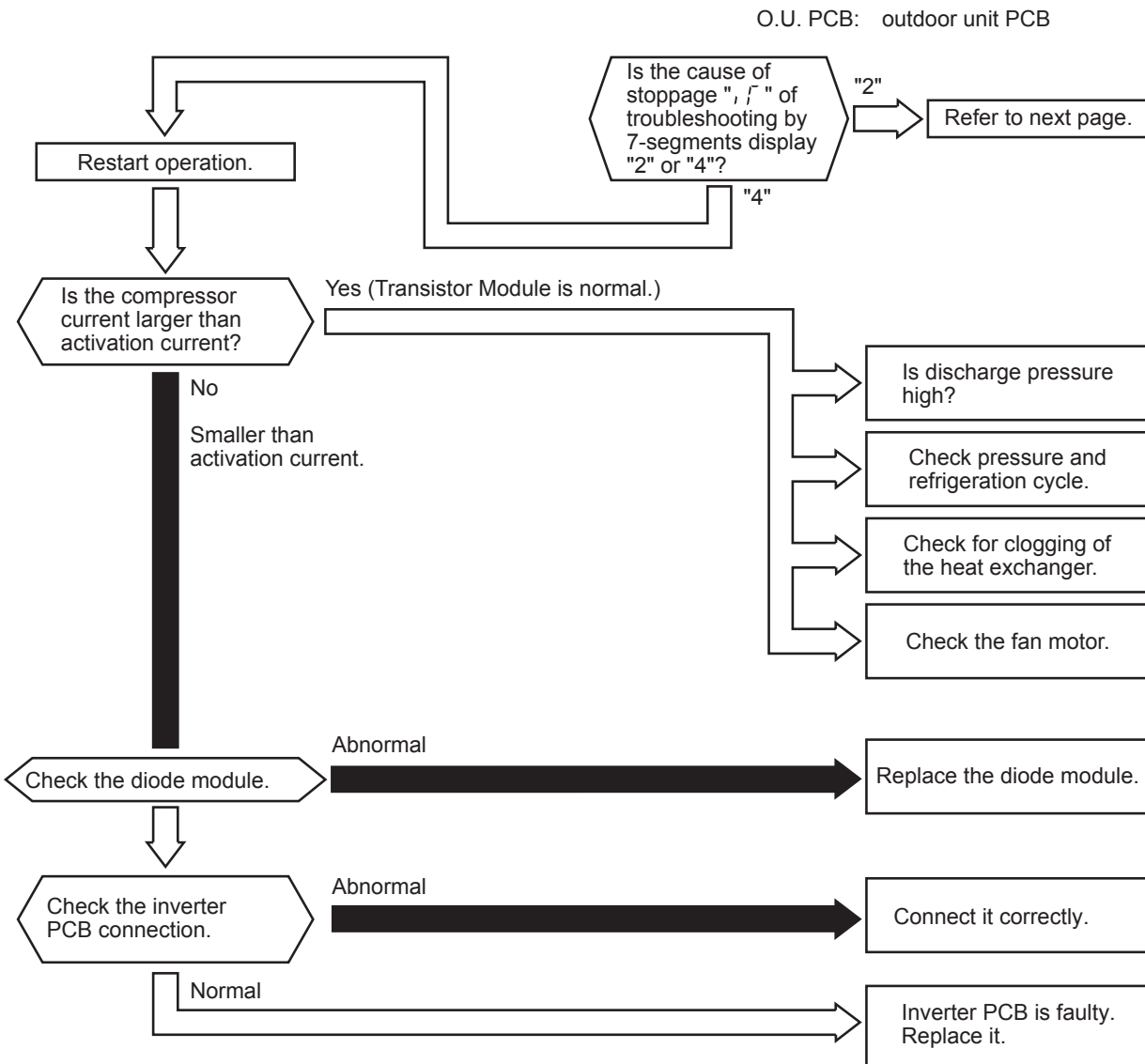

iTC	Cause of inverter stoppage
2	Instantaneous overcurrent
4	Inverter overcurrent

Alarm Code	48	Activation of Inverter Overcurrent Protection Device (2)
------------	----	--

- The RUN indicator (Red) is flashing.
- The indoor unit number, the alarm code, the unit model code and the connected number of indoor units are displayed on LCD. Meanwhile, the indoor unit number and the alarm code are displayed on the 7-segment of outdoor unit PCB.

★ This alarm code is indicated when instantaneous overcurrent occurs six times within 30 minutes.
 (Retry operation is performed up to the occurrence of five times.)
 Conditions of Activation: Inverter current with 150% of the rated current

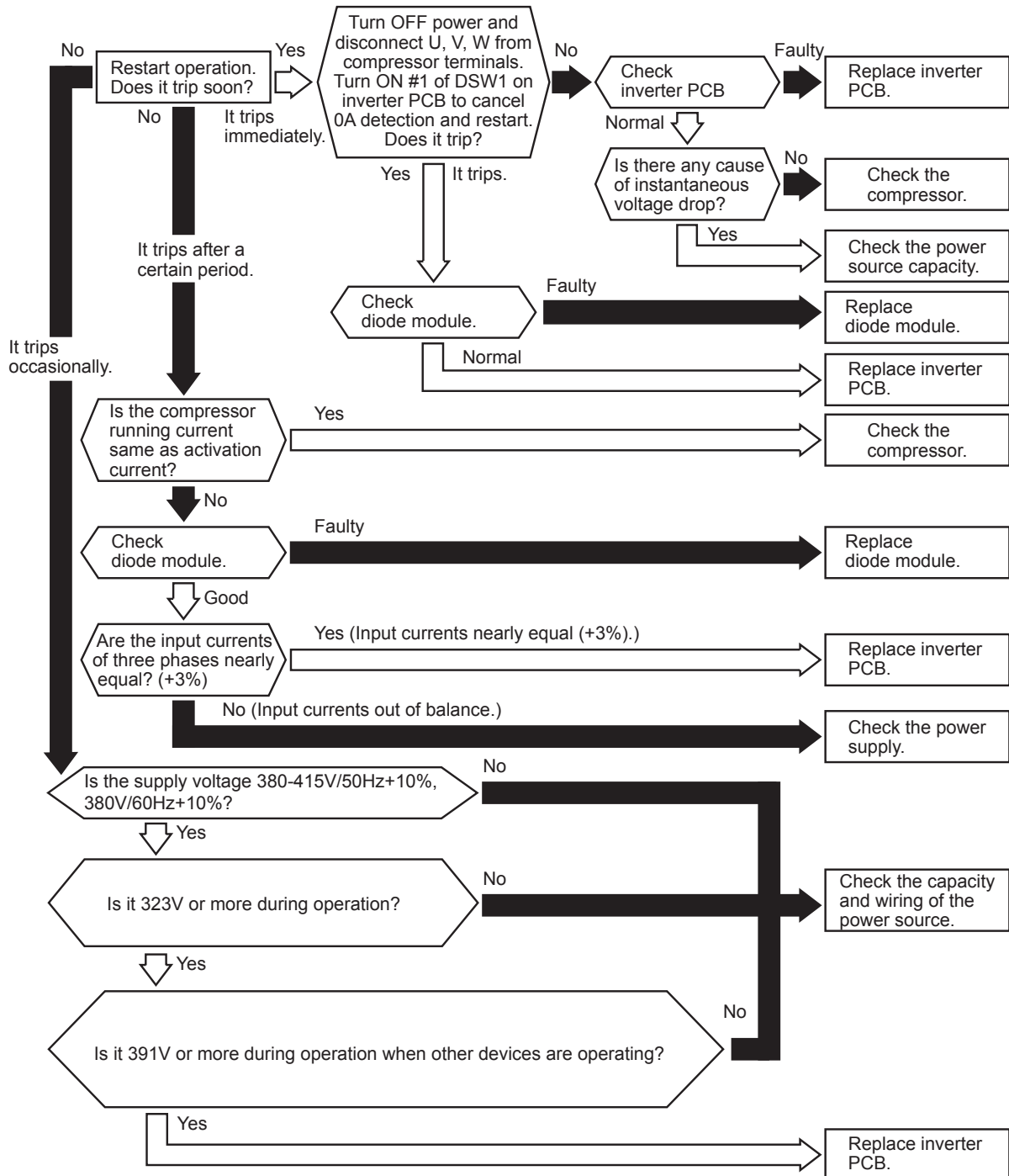

Alarm Code	51	Abnormality of Current Sensor
------------	----	-------------------------------

- The RUN indicator (Red) is flashing.
- The indoor unit number, the alarm code, the unit model code and the connected number of indoor units are displayed on LCD. Meanwhile, the indoor unit number and the alarm code are displayed on the 7-segment of outdoor unit PCB.

★ In case that the abnormality of current transformer (0A detecting) occurs three times within 30 minutes, this alarm code is indicated at the third time.

(Retry operation is performed for the first two times.)

Condition of Activation:

- (1) When the frequency of compressor is maintained at 15 to 18Hz after compressor is started, one of the absolute value of running current detected by the current transformer at each phase U+, U-, V+ and V- is less than 1.5A (including 1.5A).
- (2) The wave height value of running current for the phase positioning is less than 5A before the compressor is started (at completing the phase positioning).

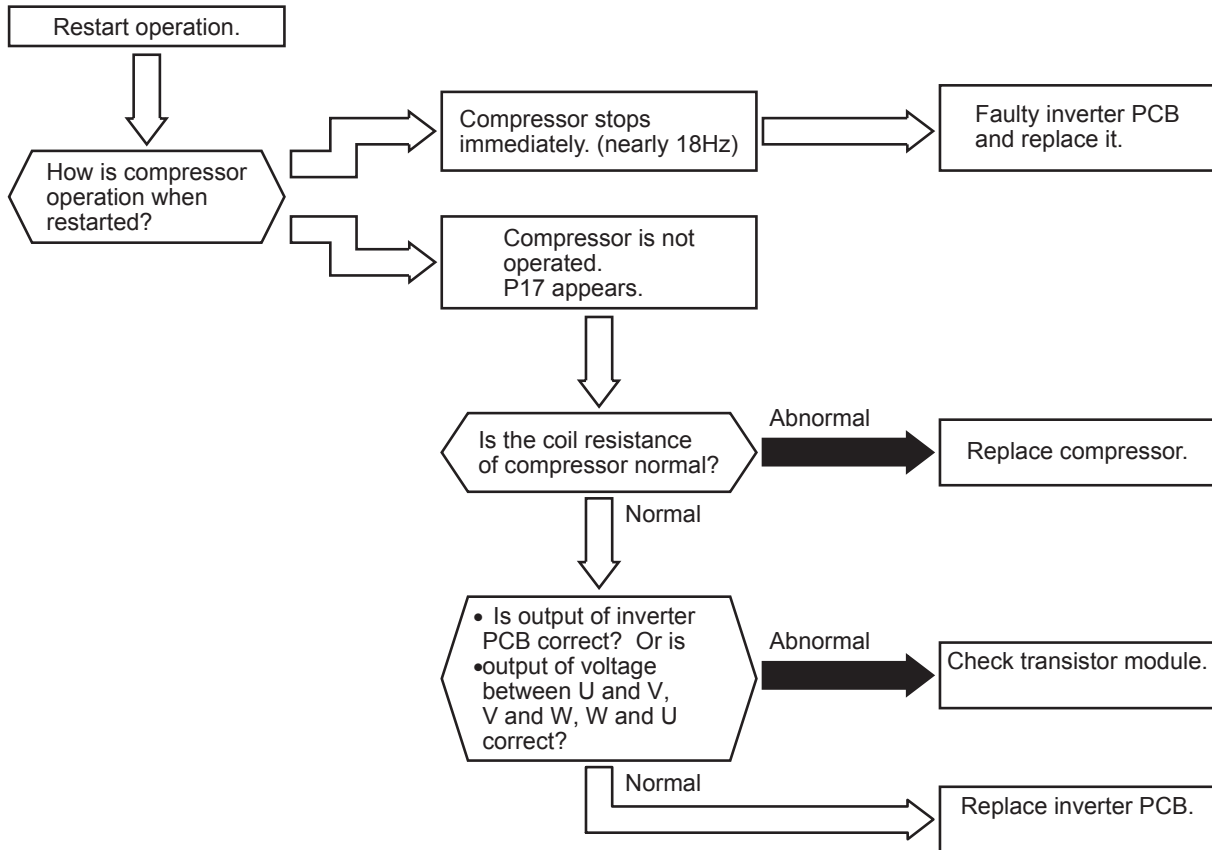

iTC	Cause of inverter stoppage
8	Abnormal current sensor or imbalance of U/V/W

Alarm Code	53	Inverter Error Signal Detection
------------	----	---------------------------------

- The RUN indicator (Red) is flashing.
- The indoor unit number, the alarm code, the unit model code and the connected number of indoor units are displayed on LCD. Meanwhile, the indoor unit number and the alarm code are displayed on the 7-segment of outdoor unit PCB.

★ IPM (Transistor Module) has abnormality-detecting function.

This alarm code is indicated when the abnormality is detected seven times within 30 minutes. (Retry operation is performed for the first 6 times.)

Condition of Activation:

- (1) The abnormal current such as a short-circuit current, a ground-fault current or the overcurrent occurs at the transistor module.
- (2) The temperature at transistor module increases abnormally.
- (3) The control voltage decreases.

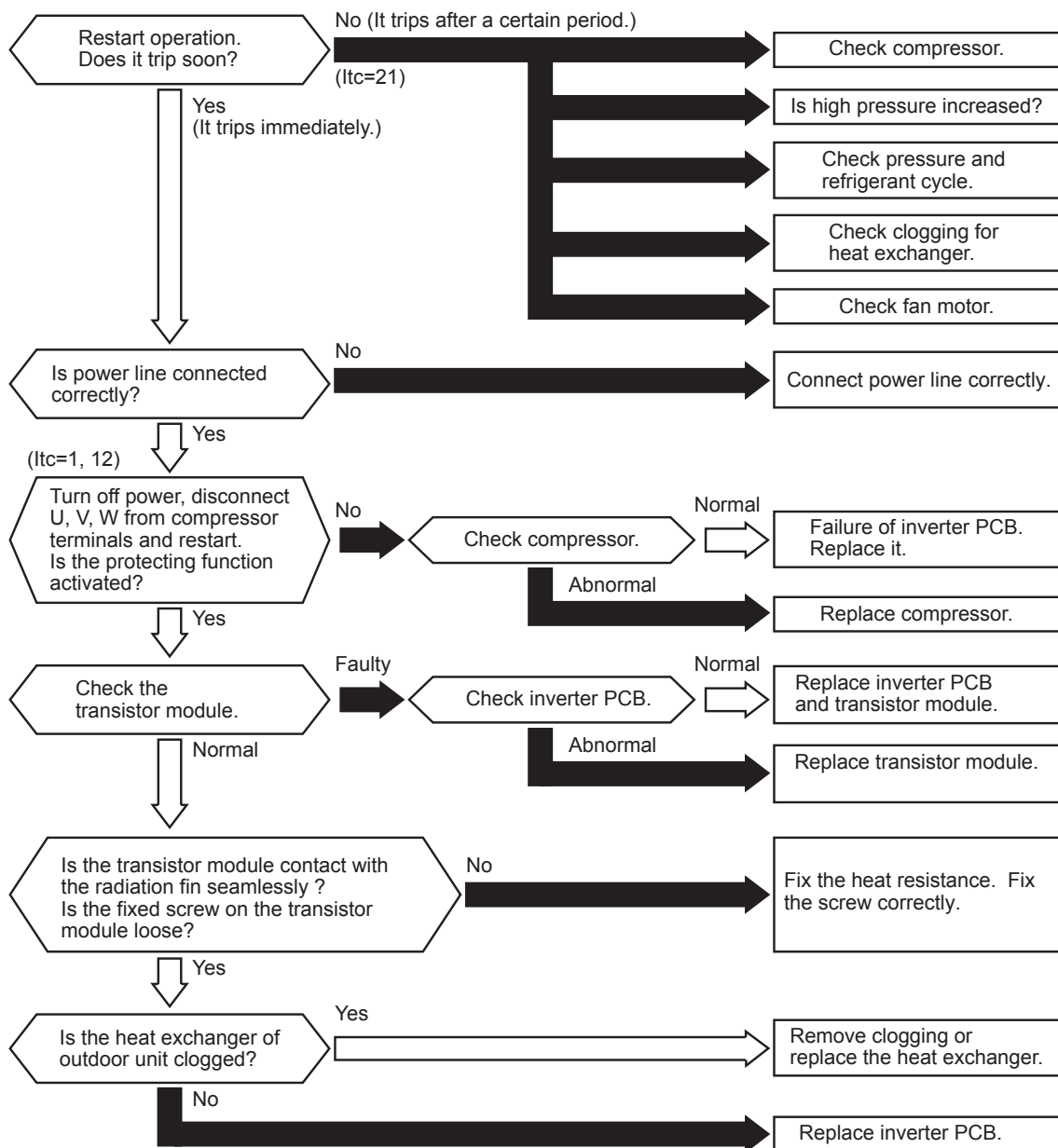

ITC	Cause of inverter stoppage
1	Activation of transistor module protection
12	Ground fault detection
21	Out-of-synchronism detection

*1): When the unit is applied with excessive surge current due to lighting or other causes, this alarm code "53" will be indicated and the unit can not be operated. In this case, check to ensure the surge absorber/surge arrester (SA) on the noise filter (NF1, NF2). The surge absorber may be damaged if the inner surface of the surge absorber is black. In that case, replace the surge absorber.
 If the inside of the surge absorber is normal, turn OFF the power once and wait until LED4 on inverter PCB is OFF (approx. 5 min.) and turn ON again.

< Position of Surge Absorber >

76/96 Models

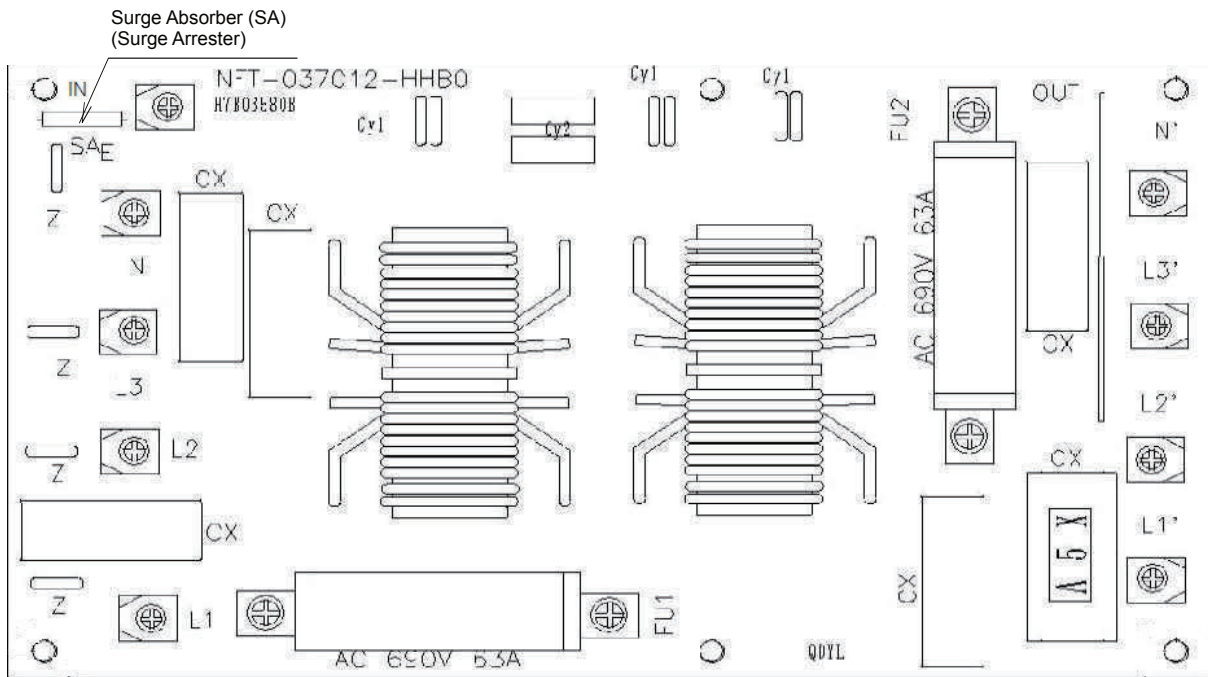

114-272 Models

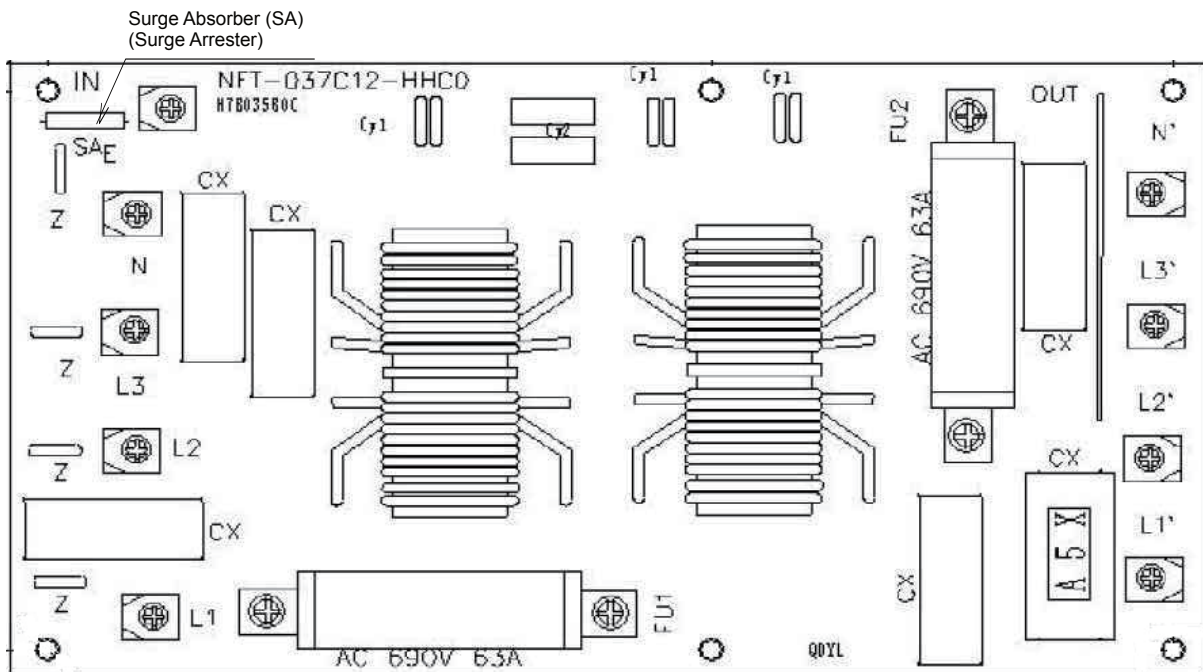

Alarm Code	54	Abnormality of Inverter Fin Temperature
------------	----	---

- The RUN indicator (Red) is flashing.
- The indoor unit number, the alarm code, the unit model code and the connected number of indoor units are displayed on LCD. Meanwhile, the indoor unit number and the alarm code are displayed on the 7-segment of outdoor unit PCB.

★ In case that the abnormality of inverter fin temperature occurs three times within 30 minutes, this alarm code is indicated at the third time.

(Retry operation is performed for the first two times.)

Conditions of Activation: The radiation fin temperature exceeds 100°C.

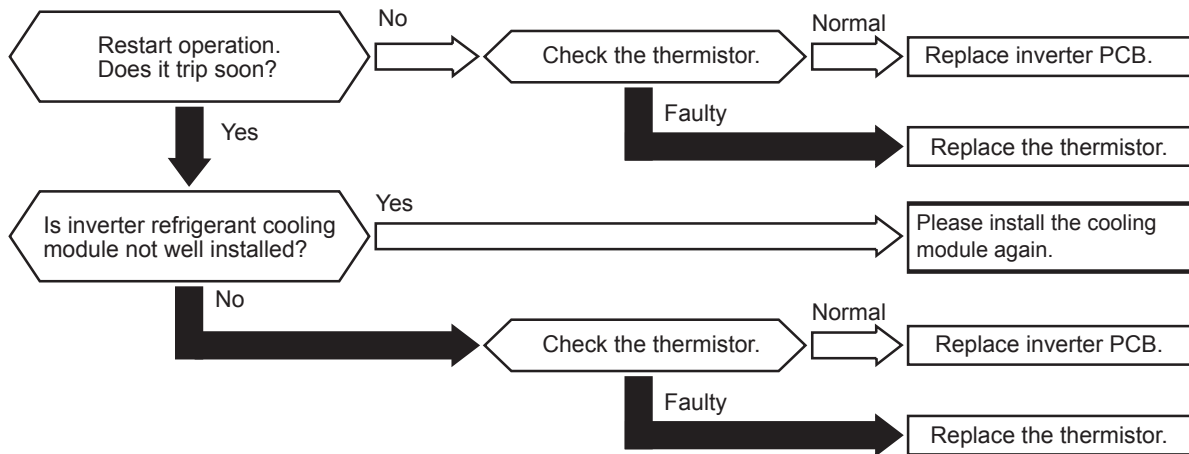

Alarm Code	55	Inverter Failure
------------	----	------------------

- The RUN indicator (Red) is flashing.
- The indoor unit number, the alarm code, the unit model code and the connected number of indoor units are displayed on LCD. Meanwhile, the indoor unit number and the alarm code are displayed on the 7-segment of outdoor unit PCB.

★ This alarm code is indicated when the following phenomenon occurs three times in 30 minutes.

(Retry operation is performed for the first two times.)

Actual frequency from inverter PCB is less than 10Hz (after inverter frequency output from outdoor unit PCB).

Conditions of Activation: Inverter PCB does not operate normally.



*1): When the unit is applied with excessive surge current due to lightning or other causes, this alarm code "55" will be indicated and the unit can not be operated. In this case, check to ensure the surge absorber/surge arrester (SA) on the noise filter (NF1, NF2). The surge absorber may be damaged if the inner surface of the surge absorber is black. In that case, replace the surge absorber.

If the inside of the surge absorber is normal, turn OFF the power once and wait until LED4 on inverter PCB is OFF (approx. 5 min.) and turn ON again.

Alarm Code	57	Activation of Fan Controller Protection
------------	----	---

- The RUN indicator (Red) is flashing.
- The indoor unit number, the alarm code, the unit model code and the connected number of indoor units are displayed on LCD. Meanwhile, the indoor unit number and the alarm code are displayed on the 7-segment of outdoor unit PCB.

★ IPM (Transistor Module) has abnormality-detecting function.

This alarm code is indicated when the abnormality is detected ten times within 30 minutes. (Retry operation is performed for the first nine times.)

Condition of Activation:

- (1) The abnormal current such as a short-circuit current, a ground-fault current or the overcurrent occurs at the transistor module.
- (2) The control voltage decreases.

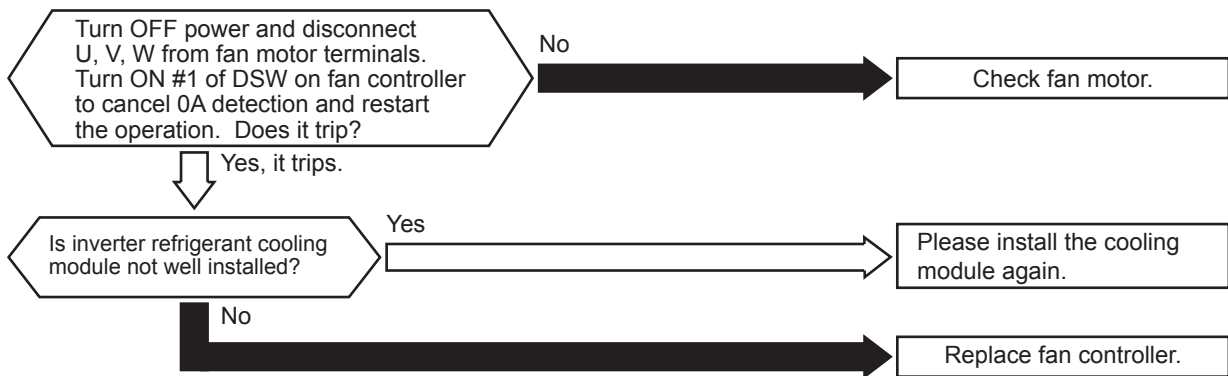

*1): When the unit is applied with excessive surge current due to lightning or other causes, this alarm code “57” will be indicated and the unit can not be operated. In this case, check to ensure the surge absorber/surge arrester (SA) on the noise filter (NF1, NF2). The surge absorber may be damaged if the inner surface of the surge absorber is black. In that case, replace the surge absorber. If the inside of the surge absorber is normal, turn OFF the power once and wait until LED4 on inverter PCB is OFF (approx. 5 min.) and turn ON again.

Alarm Code	5A	Abnormality of Fan Controller Fin Temperature
------------	----	---

- The RUN indicator (Red) is flashing.
- The indoor unit number, the alarm code, the unit model code and the connected number of indoor units are displayed on LCD. Meanwhile, the indoor unit number and the alarm code are displayed on the 7-segment of outdoor unit PCB.

★ This alarm code is indicated when the abnormality of fin temperature occurs ten times within 30 minutes. (Retry operation is performed for the first nine times.)
 Conditions of Activation: The thermistor temperature inside transistor module exceeds 100°C.

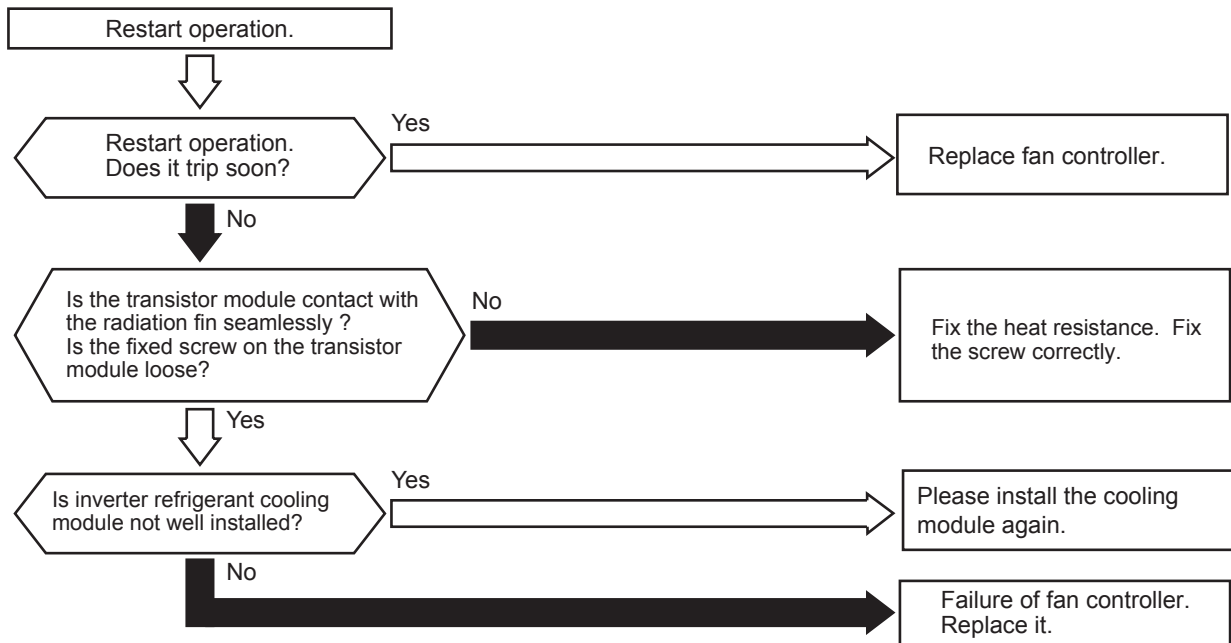

Alarm Code	56	Activation of Fan Controller Overcurrent Protection Device (1)
------------	----	--

- The RUN indicator (Red) is flashing.
- The indoor unit number, the alarm code, the unit model code and the connected number of indoor units are displayed on LCD. Meanwhile, the indoor unit number and the alarm code are displayed on the 7-segment of outdoor unit PCB.

★ This alarm code is indicated when fan controller electronic thermal protection is activated ten times within 30 minutes.

(Retry operation is performed for the first nine times.)

Conditions of Activation:

- (1) Electric current with 105% of the rated current runs for 30 seconds continuously.
- (2) Electric current runs intermittently and the accumulated time reaches up to 3 minutes, in 10 minutes.

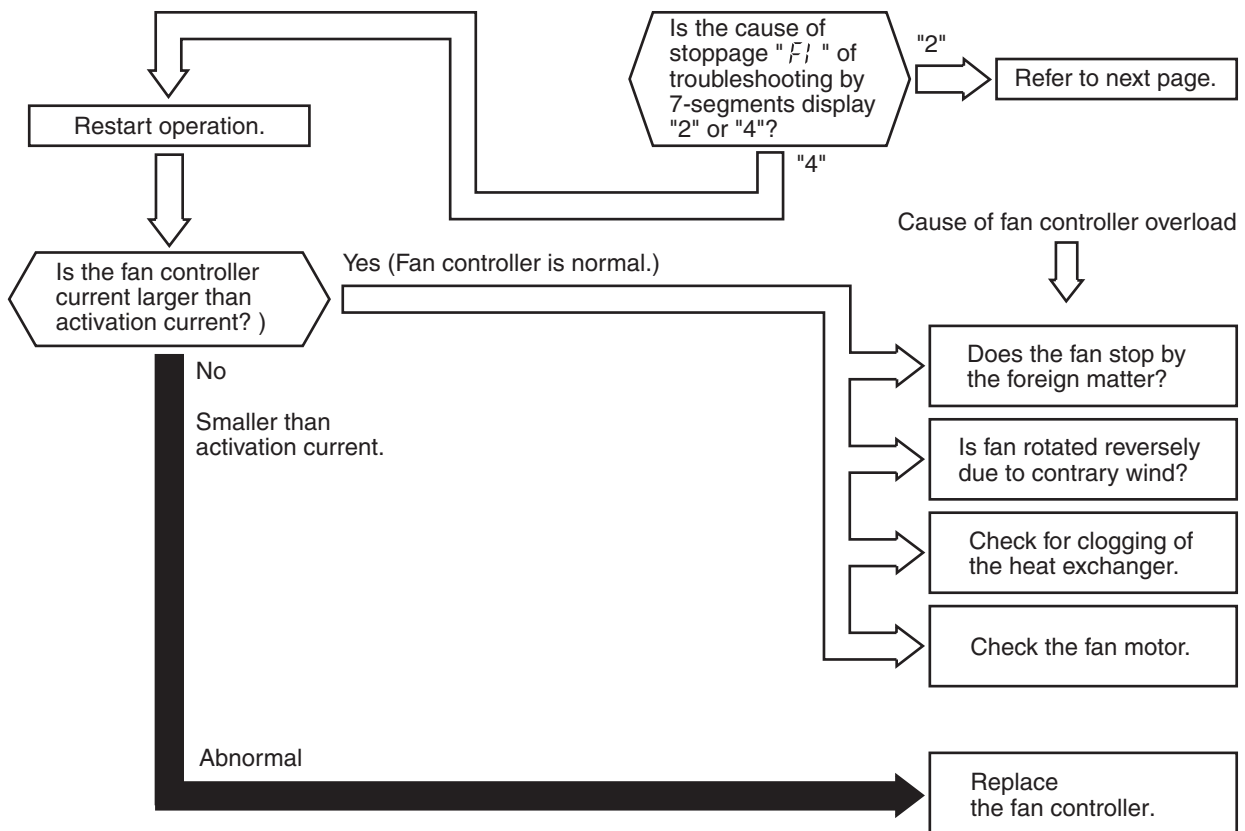

Alarm Code	56	Activation of Fan Controller Overcurrent Protection Device (2)
------------	-----------	--

- The RUN indicator (Red) is flashing.
- The indoor unit number, the alarm code, the unit model code and the connected number of indoor units are displayed on LCD. Meanwhile, the indoor unit number and the alarm code are displayed on the 7-segment of outdoor unit PCB.

★ This alarm code is indicated when instantaneous overcurrent occurs ten times within 30 minutes.

(Retry operation is performed for the first nine times.)

Conditions of Activation: The running current exceeds the rated current of transistor module.

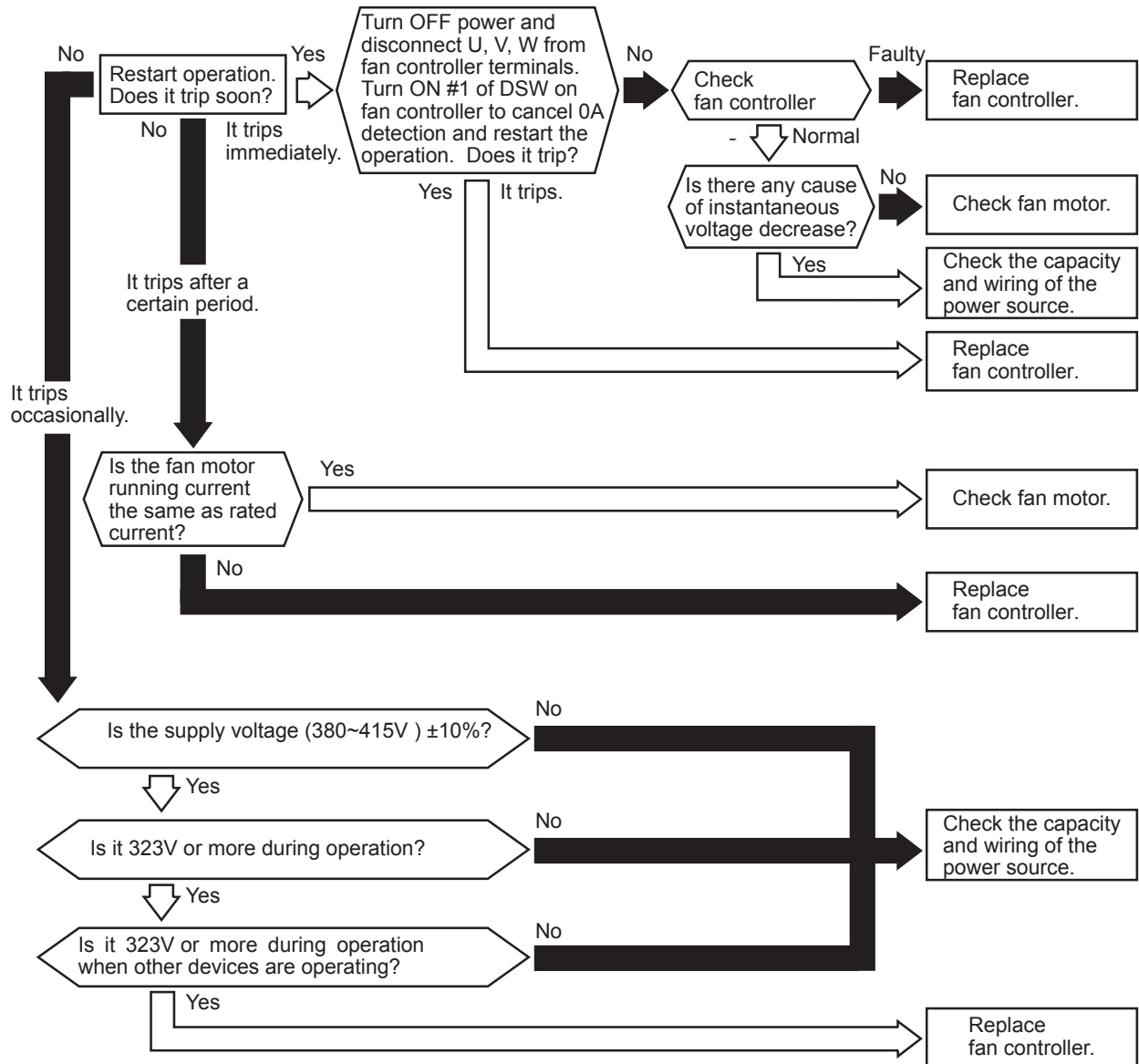

Alarm Code	5E	Abnormality of Fan Controller Sensor
------------	----	--------------------------------------

★ Conditions of Activation:

This alarm code is indicated when the following conditions occur.

- (1) After fan motor operation is started, fan controller current does NOT exceed 1.5A.
- (2) Before fan motor operation is started (at completing the phase positioning), the wave height value of running current for the phase positioning is less than 4A.

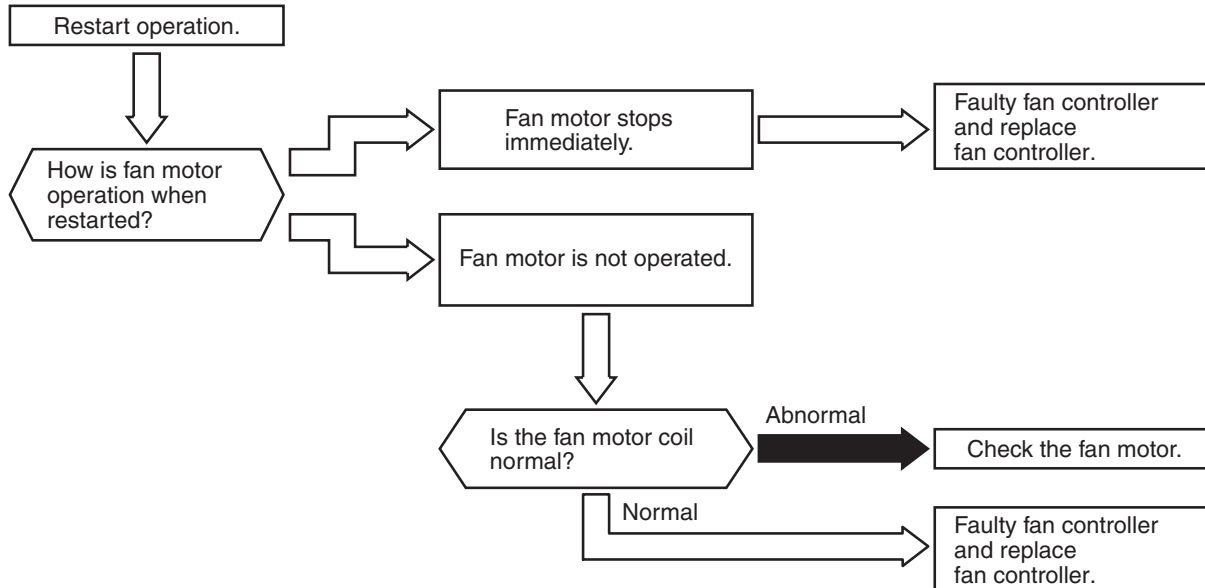

Alarm Code	EE	Compressor Protection
------------	----	-----------------------

★ This alarm code appears when one of the following alarms occurs three times within 6 hours, which may result in serious compressor damages, if the outdoor unit is continuously operated without removing the cause. This alarm code can NOT be reset from the remote control switch.

Alarm Code:	Content of Abnormality
02	Activation of Protection Device (High Pressure Cut)
07	Decrease in Discharge Gas Superheat
08	Increase in Discharge Gas Temperature
39	Abnormality of Running Current at Constant Speed Compressor
43	Activation of Low Compression Ratio Protection Device
44	Activation of Low Pressure Increase Protection Device
45	Activation of High Pressure Increase Protection Device
47	Activation of Low Pressure Decrease Protection Device (Vacuum Operation Protection)

These alarms can be checked by the CHECK Mode 1. Follow the action indicated in each alarm chart. These alarms are cleared only by turning OFF the main power switch to the system. **However, great care must be taken before starting, since there is a possibility of causing serious damages to the compressors.**

Alarm Code	A6	Abnormal Condensation During Refrigerant Heat Dissipation
------------	-----------	---

- The RUN indicator (Red) is flashing.
- The indoor unit number, the alarm code, the unit model code and the connected number of indoor units are displayed on LCD. Meanwhile, the indoor unit number and the alarm code are displayed on the 7-segment of outdoor unit PCB.

★ This alarm code is indicated when any one of the following conditions occurs twice more within the next 60 minutes.

1. The temperature of sub cooler inlet pipe is lower than ambient temperature.
2. The inverter fin temperature is lower than ambient temperature.

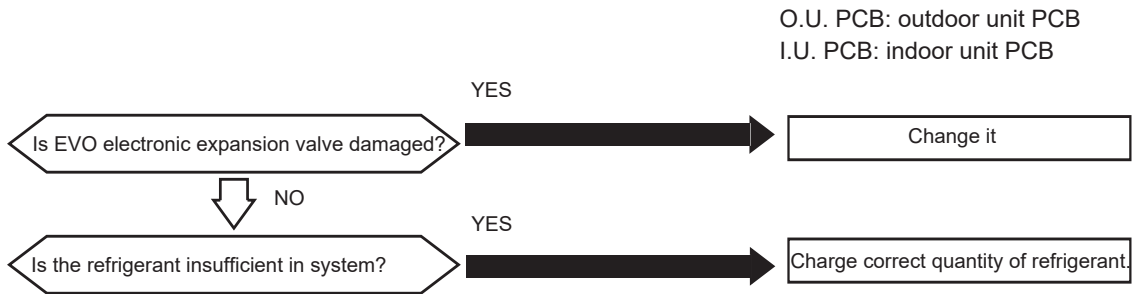

Alarm Code	61	Incorrect Setting of Unit and Refrigerant Cycle Number
------------	----	--

- The RUN indicator (Red) is flashing.
- The indoor unit number, the alarm code, the unit model code and the number of connected indoor units are displayed on LCD. Meanwhile, the indoor unit number and the alarm code are displayed on the 7-segment of outdoor unit PCB.

★ This alarm code is indicated in the following condition. Check dip switches and rotary switches after turning OFF the power source.

Unit No. Setting	Conditions	Action
1~64 (Recommended)	The unit number setting (DSW6 and RSW1) or the refrigerant cycle setting (DSW5 and RSW2) is set more than "64", or more than 2 pins are set at DSW5 or DSW6.	Set the unit number setting and the refrigerant cycle setting less than "64".
0~63	The unit number setting (DSW6 and RSW1) or the refrigerant cycle setting (DSW5 and RSW2) is set more than "63", or more than 2 pins are set at DSW5 or DSW6.	Set the unit number setting and the refrigerant cycle setting less than "63".
The unit number setting and the refrigerant number setting are set between "16" and "63", and the indoor unit does not correspond to H-NET .		Set the unit number and the refrigerant cycle setting between "0" and "15".

Alarm Code	65	Incorrect Setting of Indoor Unit Number for H-NET Type
------------	----	--

- The RUN indicator (Red) is flashing.
- The indoor unit number, the alarm code*), the unit model code and the number of connected indoor units are displayed on LCD. Meanwhile, the indoor unit number and the alarm code are displayed on the 7-segment of outdoor unit PCB.

*) : The alarm code indicated on the remote control switch is "35".

Condition	Action
The number of the connected indoor units not supporting H-NET is 17 and after	The number of the connected indoor units shall be 16 and before.

1.2.3 Troubleshooting in Check Mode by Remote Control Switch

1.2.3.1 Check mode

Each "Check Menu" item and its function are explained in the follow table.

Check Menu Item	Function
Check 1	Sensor condition of air conditioner will be monitored and indicated.
Check 2	Sensor data of air conditioner prior to alarm occurrence will be indicated.
Alarm History Display	Previous alarm record (date, time, alarm code) will be indicated.

• Setting Method

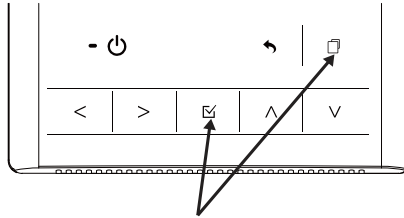

Press and hold "☰" (menu) and "☑" simultaneously for at least 3 seconds during the normal mode. The check menu will be displayed.

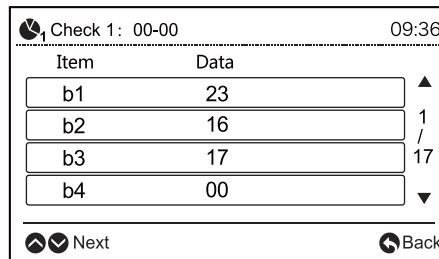
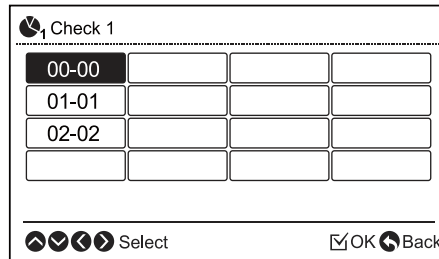
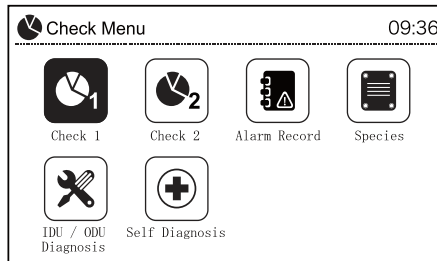

(1) Contents of Check Mode 1

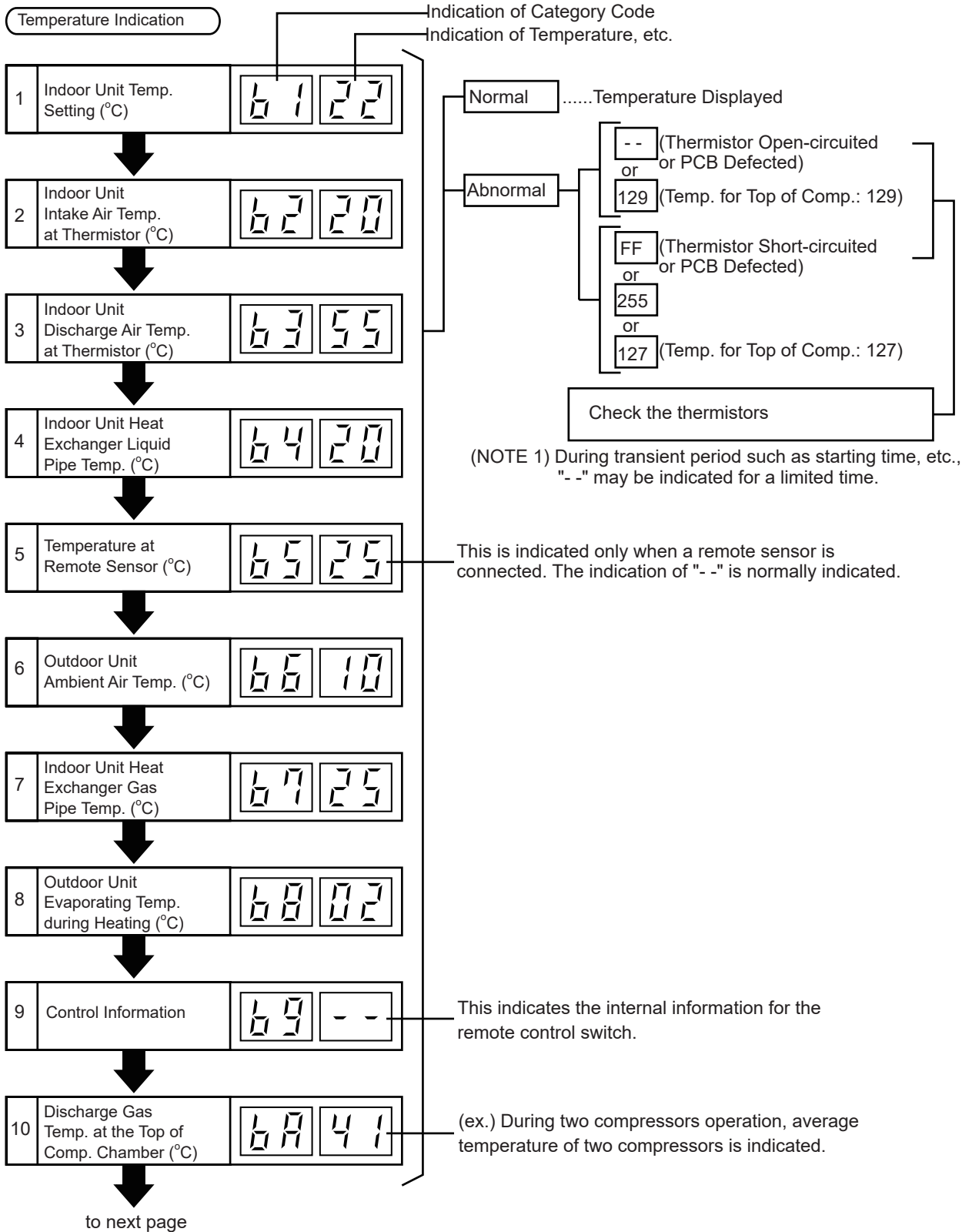

11 Thermo Temp. of Remote Control Switch bb 23

Indication on Micro-Computer Input/Output

12 Micro-Computer Input/Output in Indoor Unit E1 4

13 Micro-Computer Input/Output in Outdoor Unit E2 -

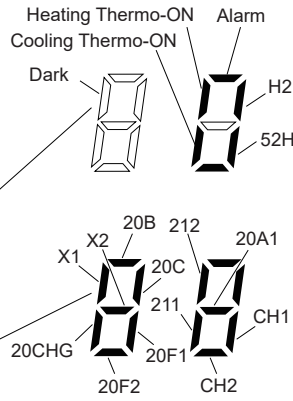

Indication of Unit Stoppage Cause

14 Cause of Stoppage d1 01

Abnormality Occurrence Counter

15 Abnormality Occurrence Times E1 01

16 Instantaneous Power Failure Occurrence Times in Indoor Unit E2 00

17 Transmission Error Occurrence Times between Remote Control Switch and Indoor Unit E3 00

18 Abnormality Occurrence Times on Inverter E4 00

Indication of Automatic Louver Condition

19 Louver Sensor F1 00

00	Operation OFF, Power OFF
01	Thermo-OFF (NOTE 1), Activating Float Switch
02	Alarm (NOTE 2)
03	Freeze Protection, Overheating Protection
05	Instantaneous Power Failure at Outdoor Unit, Reset (NOTE 3)
06	Instantaneous Power Failure at Indoor Unit, Reset (NOTE 4)
07	Stoppage of Cooling Operation due to Low Outdoor Air Temperature, Stoppage of Heating Operation due to High Outdoor Air Temperature
09	Reversing Valve Changeover, Stoppage
10	Demand, Enforced Stoppage
11	Retry due to Pressure Ratio Decrease
12	Retry due to Low Pressure Increase
13	Retry due to High Pressure Increase
14	Retry due to Abnormal Current of Constant Compressor
15	Retry due to Abnormal High Temperature of Discharge Gas, Excessively Low Suction Pressure
16	Retry due to Decrease of Discharge Gas Superheat
17	Retry due to Inverter Abnormality
18	Retry due to Voltage Decrease, Other Retry due to Inverter
19	Expansion Valve Opening Change Protection
21	Thermo-OFF by Oil Return Control
22	Hot Start of Outdoor Unit
23	Thermo-OFF due to One-Key Refrigerant Recovery
26	Retry due to High Pressure Decrease
28	Cold Draft Control
30	Thermo-OFF due to Compressor Forced Stop
32	Retry due to Excessive Outdoor Unit Number
42	Abnormal condensation during refrigerant heat dissipation

(NOTE 1) Explanation of Term,

Thermo-ON: A condition that an indoor unit is requesting compressor to operate.

Thermo-OFF: A condition that an indoor unit is not requesting compressor to operate.

(NOTE 2) Even if stoppage is caused by "Alarm", "02" is not always indicated.

(NOTE 3) If transmission between the inverter printed circuit board and the control printed circuit board is not performed during 30 seconds, the outdoor unit is stopped. In this case, stoppage is d1-05 cause and the alarm code "04" may be indicated.

(NOTE 4) If transmission between the indoor unit and the outdoor unit is not performed during 3 minutes, indoor units are stopped. In this case, stoppage is d1-06 cause and the alarm code "03" may be indicated.

Countable up to 99.

Over 99 times, "99" is always indicated.

(NOTE 1) If a transmitting error continues for 3 minutes, one is added to the occurrence times.

to next page

Compressor Pressure/Frequency Indication

20 Discharge Pressure (High) (x 0.1 MPa) 41 18



21 Suction Pressure (Low) (x 0.01 MPa) 42 04



22 Control Information 43 44

This is an indication for internal information for the remote control switch. This does not have any specific meaning.



23 Operation Frequency (Hz) 44 44

This is an indication for frequency of Inverter.



Indoor Unit Capacity Indication

24 Indoor Unit Capacity 11 08

The capacity of the indoor unit is indicated as shown in the table below.

Capacity Code of Indoor Unit

Indication Code	Equivalent Capacity (HP)
06	0.8
08	1.0
10	1.3
13	1.5
14	1.8
16	2.0
18	2.3
20	2.5
22	2.8
26	3.0
32	4.0
40	5.0
64	8.0
80	10.0



25 Outdoor Unit Code 12 Fn



26 Refrigerant Cycle Number 13 01



27 Refrigerant Cycle Number 14 00

"n" indicates total number of indoor units;

n = 1~9, A, b, C, d, E, F, U
(10) (11) (12) (13) (14) (15) (16)



Expansion Opening Indication

28 Indoor Unit Expansion Valve Opening (%) 11 20

J3: 01 to 16

(01: when shipment (DSW5), Decimal Indication)

J4: 00 to 0F

(00: when shipment (DSW5), Indication with 16 numbers)



29 Outdoor Unit Expansion Valve MV1 Opening (%) 12 99



30 Outdoor Unit Expansion Valve MV2 Opening (%) 13 99

In case of models without Expansion Valve (MV2), the same figure is indicated.



31 Outdoor Unit Expansion Valve MVB Opening (%) 14 00



Estimated Electric Current Indication

32 Compressor Running Current (A) P1 25

The total current is indicated when several compressors are running.

In case of inverter compressor, the running current of primary side of inverter is indicated.

Returns to Temperature Indication

Temperature Indication

(2) Contents of Check Mode 2

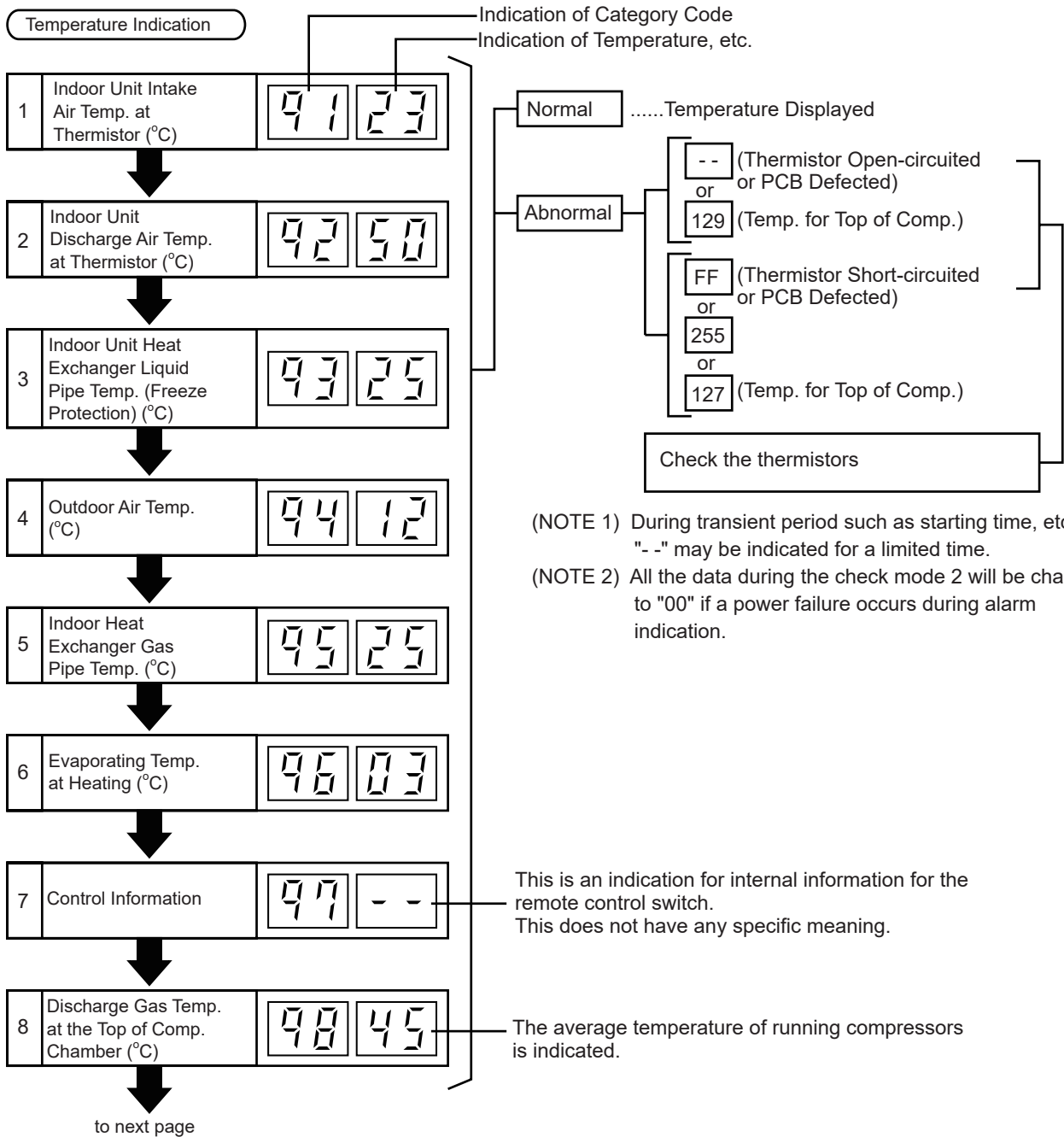

Compressor Pressure/Frequency Indication

9	Discharge Pressure (High) (x 0.1 MPa)	99	18
---	---------------------------------------	----	----



10	Suction Pressure (Low) (x 0.01 MPa)	9A	04
----	-------------------------------------	----	----



11	Control Information	96	44
----	---------------------	----	----

This is an indication for internal information for the remote control switch. This does not have any specific meaning.



12	Operating Frequency (Hz)	97	44
----	--------------------------	----	----

This is an indication for frequency of inverter.



Expansion Opening Indication

13	Indoor Unit Expansion Valve Opening (%)	9d	20
----	---	----	----



14	Outdoor Unit Expansion Valve MV1 Opening (%)	9E	99
----	--	----	----



Estimated Electric Current Indication

15	Compressor Running Current (A)	9F	20
----	--------------------------------	----	----

The total value is indicated when two compressors are running.



Returns to Temperature Indication

Temperature Indication

1.2.3.2 Alarm History Display

The alarm history display is available to be set from the check menu.

- Setting Method

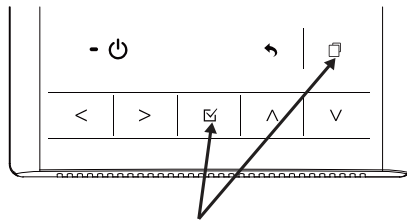

Press and hold "☰" (menu) and "☑" simultaneously for at least 3 seconds during the normal mode. The check menu will be displayed.

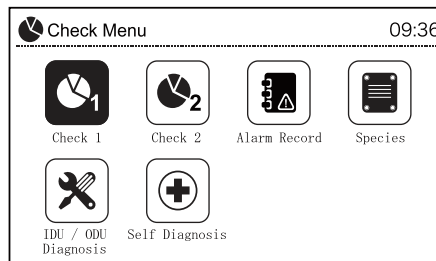

- Select "Alarm Record"
 - ※ To Erase Alarm Record

Press "☑" when the abnormality record is indicated. After that, the confirmation interface will be displayed. Select "yes" and press "☑" so that the alarm record will be deleted.

1.2.4 Troubleshooting by 7-Segment Display

Only the authorized person can check with this method. Operating conditions and each part of refrigeration cycle can be checked by 7-segment and push switches on the PCB in the outdoor unit.

(1) Before Checking

(a) Turn ON main power source. Wait for more than 20 seconds to start checking.

(b) Checking Items

- * Connecting Information
- * Outdoor Unit Information
- * Indoor Unit Information
- * Cause of Alarm Code Information
- * Alarm Code History Information

(c) Check the location of 7-segment and push switches.



WARNING

AC220-240V is applied to PCB and electrical parts. Never touch electrical parts and wires when checking.

(2) Location of Push Switches and 7-Segment Display

The push switches and 7-segment display are located on the outdoor unit PCB.

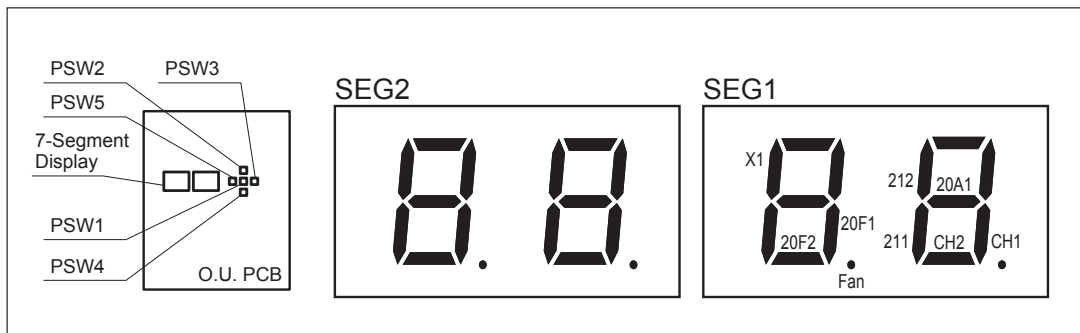

Mark	Description of Mark	Parts Mark in Wiring Diagram
52C1	-	-
52C2	-	-
CH1	Contactora of Relay (YCH1) on O.U. PCB for Crankcase Heater	CH1
CH2	Contactora of Relay (YCH2) on O.U. PCB for Crankcase Heater	CH2
20A1	Contactora of Relay (Y20A) on O.U. PCB for Solenoid Valve	SVA
20A2	-	-
211	-	-
21 ₂	Contactora of Relay (Y ₂₁₂) on O.U. PCB for Reversing Valve	RVR2
FAN	-	-
20B	-	-
20C	Contactora of Relay (20C) on O.U. PCB for Solenoid Valve	SVC
20F1	-	-
20F2	-	-
20CHG	-	-
X1	-	-
X2	-	-

(3) Protection Control Code on 7-Segment Display

- * Protection control code is displayed on 7-segment during operation when a protection control is activated.
- * Protection control code is displayed while function is working, and goes out when released.
- * When several protection controls are activated, code number with higher priority will be indicated (see below for the priority order).

(a) Higher priority is given to the protection control related to frequency control than the others.

< Priority Order >

- | | |
|---|---|
| <1> Pressure Ratio Control | <6> Low-Pressure Decrease Protection |
| <2> High-Pressure Increase Protection | <7> Demand Current Control
(Running Current Limit Control) |
| <3> Current Protection | <8> Low-Pressure Increase Protection |
| <4> Inverter Fin Temperature Increase Protection | <9> High-Pressure Decrease Protection |
| <5> Discharge Gas Temperature Increase Protection | |

(b) In relation to retry control, the latest retry code will be indicated unless a protection control related to frequency control is indicated.

Code	Protection Control	Code during Degeneration Control
P01	Pressure Ratio Protection Control	Pc1
P02	High-Pressure Increase Protection	Pc2
P03	Inverter Current Protection	Pc3
P04	Inverter Fin Temperature Increase Protection	Pc4
P05	Discharge Gas Temperature on Top of Compressor Increase Protection	Pc5
P06	Low-Pressure Decrease Protection	Without
P09	High-Pressure Decrease Protection	
P0A	Demand Current Protection Control	
P0d	Low-Pressure Increase Protection	

Code	Retry Control	Code during Degeneration Control
P11	Pressure Ratio Decrease Retry	Without
P12	Low-Pressure Increase Retry	
P13	High-Pressure Increase Retry	
P15	Discharge Gas Temperature Increase Retry/Low-Pressure Decrease Retry	
P16	Discharge Gas SUPERHEAT Decrease Retry	
P17	Inverter Abnormality Retry	
P18	Abnormal Inverter Voltage Retry/Inverter Failure Retry	
P26	High-Pressure Decrease Retry	

NOTE:

- (1) Retry indication continues for 30 minutes unless a protection control is indicated.
- (2) Retry indication disappears if the stop signal comes from all rooms.
- (3) The protection control code indicated on 7-segment display changes to an alarm code when an abnormal operation occurs. Also, the same alarm code is indicated on the remote control switch.
- (4) In case that the degeneration control is activated, the indications Pc1 to Pc5 are indicated instead of P01 to P05.

(4) Activating Condition of Protection Retry Control Code

Protection Control or Retry Control is performed to prevent the abnormal operation.

The activating conditions are shown in the table below.

Code	Protection Control	Activating Condition	Remarks								
P01	Pressure Ratio Protection Control	Compression Ratio $\varepsilon \geq 9$ or Compression Ratio $\varepsilon \leq 1.5$	-								
P02	High-Pressure Increase Protection	$P_d \geq 3.65$ (at Cooling Mode) $P_d \geq 3.5$ (at Heating Mode)	-								
P03	Inverter Current Protection	Inverter Output Current $\geq (a)A$ <table border="1" style="margin-left: 20px;"> <thead> <tr> <th>INV. Comp.</th> <th>a</th> </tr> </thead> <tbody> <tr> <td>ATH550SKRC8FQP</td> <td>29.0</td> </tr> <tr> <td>ATE650SKTQ9JKP</td> <td>31.0</td> </tr> <tr> <td>ATE848SKTQ9JKP</td> <td>34.5</td> </tr> </tbody> </table>	INV. Comp.	a	ATH550SKRC8FQP	29.0	ATE650SKTQ9JKP	31.0	ATE848SKTQ9JKP	34.5	-
INV. Comp.	a										
ATH550SKRC8FQP	29.0										
ATE650SKTQ9JKP	31.0										
ATE848SKTQ9JKP	34.5										
P04	Inverter Fin Temperature Increase Protection	Inverter Fin Temperature $\geq 100^\circ C$	-								
P05	Discharge Gas Temperature Increase Protection	Temperature at the Top of Compressor $T_d > 108^\circ C$	-								
P06	Low-Pressure Decrease Protection	Suction Pressure $P_s \leq 0.1 MPa$	-								
P09	High-Pressure Decrease Protection	Discharge Pressure $P_d \leq 1.0 MPa$	-								
P0A	Demand Current Protection Control	Running Current for Compressor $>$ Demand Current Setting Value	Demand Current Setting Value: Upper limit of total running current is set 100%, 80%, 70%, 60% and 40% at normal operation.								
P0d	Low-Pressure Increase Protection	Suction Pressure $\geq P_{sat}$ MPa $P_{sat} = 1.3$ $T_a \leq 44^\circ C$, $P_{sat} = 1.5$ $T_a > 44^\circ C$	-								

Code	Retry Control	Activating Condition	Remarks
P11	Pressure Ratio Decrease Retry	Pressure Ratio $\varepsilon < 1.8$ over 1.5 minutes	When activating 3 times in 30 minutes, "43" alarm is indicated.
P12	Low-Pressure Increase Retry	$P_s > 1.8 MPa$ over 1 minute $1.8 T_a > 44^\circ C$ $1.4 T_a \leq 44^\circ C$	When activating 3 times in 30 minutes, "44" alarm is indicated.
P13	High-Pressure Increase Retry	$P_d \geq 3.9 MPa$ over 2 seconds	When activating 3 times in 30 minutes, "45" alarm is indicated.
P15	Discharge Gas Temperature Increase Retry	Discharge Gas Temperature $\geq 130^\circ C$ over 10 minutes or Discharge Gas Temperature $\geq 125^\circ C$ over 5 seconds	When activating 3 times in 60 minutes, "08" alarm is indicated.
	Low-Pressure Decrease Retry	$P_s < 0.09 MPa$ over 12 minutes	When activating 3 times in 60 minutes, "47" alarm is indicated.
P16	Discharge Gas SUPERHEAT Decrease Retry	Discharge Gas SUPERHEAT $\leq T_c + 10$ deg. over 30 minutes. T_c : Saturation Temperature	When activating 3 times in 120 minutes, "07" alarm is indicated.
P17	Inverter Abnormality Retry	Instantaneous Overcurrent	When activating 6 times in 30 minutes, "48" alarm is indicated.
		Abnormality of Current Sensor	When activating 3 times in 30 minutes, "51" alarm is indicated.
		IPM Error	When activating 7 times in 30 minutes, "53" alarm is indicated.
		Fin Temperature $> 100^\circ C$	When activating 3 times in 30 minutes, "54" alarm is indicated.
P18	Abnormal Inverter Voltage Retry	Insufficient Voltage at Inverter Circuit	When activating 3 times in 30 minutes, "06" alarm is indicated.
		Excessive Voltage at Inverter Circuit	When activating 3 times in 30 minutes, "06" alarm is indicated.
	Inverter Failure Retry	Actual Inverter Frequency continues to be 0Hz for 3 seconds, 3 minutes after Inverter Frequency is output.	When activating 3 times in 30 minutes, "55" alarm is indicated.
P26	High-Pressure Decrease Retry	$P_d < T_a / 130 + 0.4 MPa$ over 4 minutes or $P_d < 1.0 MPa$ over 30 minutes T_a : Ambient Temperature	When activating 2 times in 30 minutes, "46" alarm is indicated.

(5) Alarm Code

Refer to the item 1.2.1.

(6) Checking Method by Checking Mode

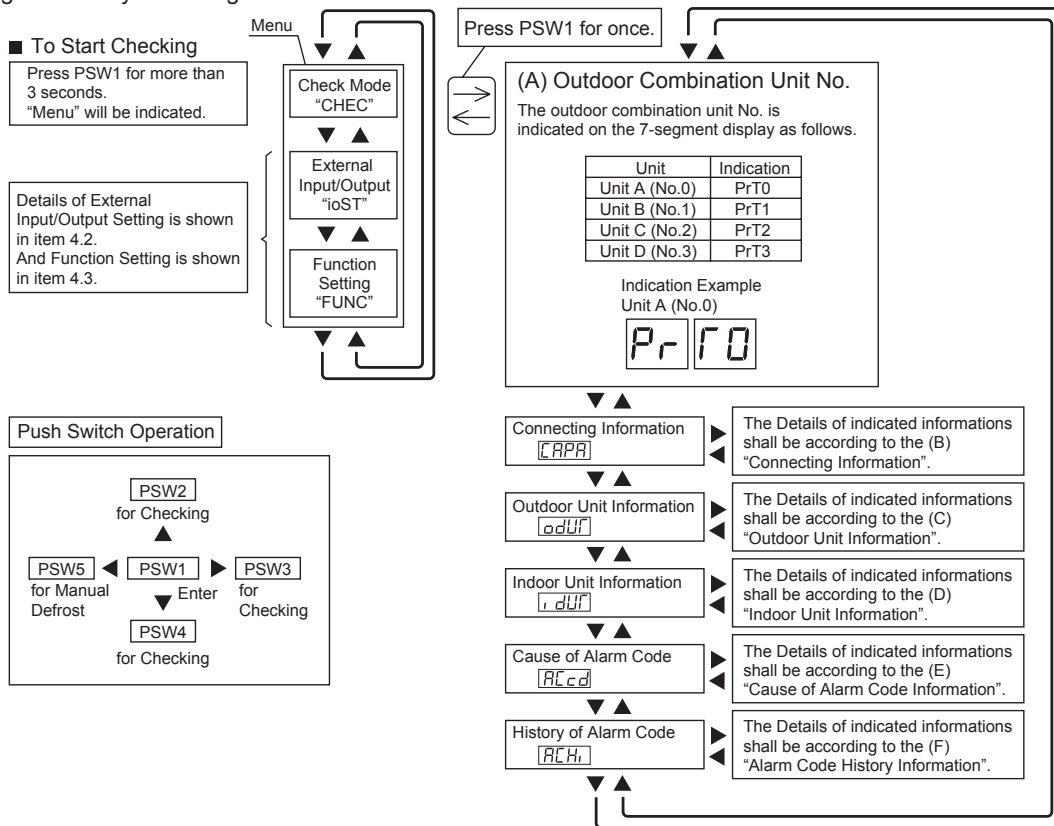

■ To Cancel Checking Method

Press "PSW1" for more than 3 seconds while "Menu Mode" is displayed. The indication of LCD will be turned off and condition will return to normal.

NOTICE

Make sure to cancel Checking Mode after checking is completed.

(A) Connecting Information

This information is indicated on the unit A (main unit) only. Press PSW4 (▼) to forward or PSW2 (▲) to backward.

Select the outdoor unit No. for indication.

Press PSW3 (▶) for details information of selected unit No.

Press PSW4 (▼) to forward or PSW2 (▲) to backward.

The information will be indicated alternately as "Item" → "Details".

Press PSW5 (◀) for return to Outdoor Unit No. Selection.

Unit	Indication
Unit A (No.0)	od00
Unit B (No.1)	od01
Unit C (No.2)	od02
Unit D (No.3)	od03

Details of Indication

Item	7-Segment Display		Details
	SEG2	SEG1	
1 Total Capacity of Connected Outdoor Units	□	CP	Total Capacity of O.U. Combination Refer to "Outdoor Unit Capacity Table".
2 O.U. Constitution Quantities	□	RR	Constitution Quantities of O.U. Combination
3 Total Capacity of Connected Indoor Units	,	CP	Total Capacity of Connected Indoor Units
4 Connected I.U. Number	,	RR	Connected Indoor Unit Number
5 Refrigerant Group		GR	Refrigerant Group Number (0 to 64)
6 Total Capacity of Operated I.U.		oP	Total Capacity of Operated Indoor Units Refer to "Indoor Unit Capacity Table".
7 Total Compressor Frequency		Ht	Unit: Hz
8 Accumulated Operation Time		UU	Unit: Hour (Indication x 10 Hours)

(B) Outdoor Unit Information

Select the outdoor combination unit No. for indication.

When the selection is changed, press PSW4 (▼) to forward or PSW2 (▲) to backward.

Select the outdoor combination unit No. for indication by pressing PSW4 or PSW2.

Press PSW3(▶) for details information.

Press PSW4(▼) to forward or PSW2(▲) to backward.

The information will be indicated alternately as “Item” → “Details”.

Press PSW5(◀) for return to Outdoor Combination Unit No. Selection.

Unit	Indication
Unit A (No.0)	od00
Unit B (No.1)	od01
Unit C (No.2)	od02
Unit D (No.3)	od03

Item	7-Segment Display		Details
	SEG2	SEG1	
1 Outdoor Unit Capacity	CR	0 ^{*3)}	Unit Capacity Indication Refer to “Outdoor Unit Capacity Table”.
2 Output State of Outdoor Micro-Computer	SC	0	Output State of Outdoor Micro-Computer Indication Refer to “Location of Push Switches and 7-Segment Display”.
3 Running Frequency of Inverter Compressor MC1	HI	0	Running Frequency of INV. Compressor Indication
4 Total Number of Running Compressor	CC	0	Total Number of Running Compressor Indication
5 Air Flow Rate	Fo	0	Air Flow Rate Indication (0 to 25 Steps)
6 Outdoor Expansion Valve MV1 Opening	E1	0	Outdoor Expansion Valve MV1 Opening Indication (Unit: %)
7 Outdoor Unit Expansion Valve MVB Opening for Bypass	Eb	0	Expansion Valve Opening for Bypass Indication (Unit: %)
8 Discharge Pressure (High)	Pd	0	Unit: MPa Indication of Thermistor Open Circuit: 552 Indication of Thermistor Short Circuit: -062
9 Suction Pressure (Low)	PS	0	Unit: MPa Indication of Thermistor Open Circuit: 225 Indication of Thermistor Short Circuit: -025
10 Ambient Air Temperature (Ta)	To	0	Unit: °C Indication of Thermistor Open Circuit: -127 Indication of Thermistor Short Circuit: 127
11 Discharge Gas Temperature on the Top of Compressor MC1 (TD1)	Td	10	Unit: °C Indication of Thermistor Open Circuit: 0 Indication of Thermistor Short Circuit: 225
12 Discharge Gas Temperature on the Top of Compressor MC2 (TD2)	Td	20	Unit: °C (Only for dual compressor system) Indication of Thermistor Open Circuit: 0 Indication of Thermistor Short Circuit: 225
13 Evaporating Temperature TE at Heating	TE	0	Unit: °C Indication of Thermistor Open Circuit: -127 Indication of Thermistor Short Circuit: 127
14 Outdoor Heat Exchanger Gas Temperature	TO	0	Unit: °C Indication of Thermistor Open Circuit: -127 Indication of Thermistor Short Circuit: 127
15 Supercooling Temperature	TC	40	Unit: °C Indication of Thermistor Open Circuit: -127 Indication of Thermistor Short Circuit: 127
16 Supercooling Temperature at Bypass	Tb	00	Unit: °C Indication of Thermistor Open Circuit: -127 Indication of Thermistor Short Circuit: 127
17 Inverter Fin Temperature	FF	,0	Unit: °C
18 Fan Controller Fin Temperature	FF	F0	Unit: °C
19 Compressor MC1 Current ^{*1)}	R1	0	Unit: A
20 Compressor MC2 Current ^{*1)}	R2	0	Unit: A (Only for dual compressor system)
21 Fan Motor (MFO1) Current ^{*1)}	RF	0	Unit: A
22 Accumulated Operation Time of Compressor MC1	UU	10	Unit: Hour (Indication x 10Hours)
23 Accumulated Operation Time of Compressor MC2	UU	20	Unit: Hour (Indication x 10Hours) (Only for dual compressor system)
24 Accumulated Operation Time of Compressor MC1	cU	10	Unit: Hour (Indication x 10Hours) Accumulated operation time can be reset. ^{*2)}
25 Accumulated Operation Time of Compressor MC2	cU	20	Unit: Hour (Indication x 10Hours) (Only for dual compressor system) Accumulated operation time can be reset. ^{*2)}
26 Cause of Inverter Stoppage	,F	10	Refer to “Inverter Stoppage Cause Table”.
27 Connected Indoor Unit Number	FF	10	Refer to “Fan Controller Stoppage Cause Table”.

*1): The indicated current is reduced value. Use a clamp meter for the accurate current value.

*2): For resetting the accumulated operation time, press “PSW1 + PSW3” for 5 seconds while the accumulated data display.

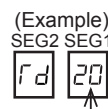

*3): The outdoor unit No. is indicated on the one digit of “SEG1”.

● Outdoor Unit Capacity Table

Indication	Capacity (kW/10)	Horsepower (HP)	Model (kBtu/h)
64	224	8.0	76
80	280	10.0	96
96	335	12.0	114
112	400	14.0	136
128	400	16.0	154
144	500	18.0	170
...
HP×8	≈HP×28	HP	≈HP×9.55

NOTE:

In case of combination unit, the indication of outdoor unit capacity is total capacity of construction units.

(C) Indoor Unit Information

This information is indicated on the unit A (main unit) only.
 Select the indoor unit number for the information indication.
 Press PSW4 (▼) to forward or press PSW2 (▲) for backward.
 Select the indoor unit No. for indication by pressing PSW4 or PSW2.
 Press PSW3 (▶) for details information of selected unit No.
 Press PSW4 (▼) to forward or PSW2 (▲) to backward.
 The information will be indicated alternately as "Item" → "Details".
 Press PSW5 (◀) for return to Indoor Unit No. Selection.

Unit No.	Indication
No. 0	1 200
No. 1	1 201
↓	↓
No.63	1 263

Details of Indication

Item	7-Segment Display		Details
	SEG2	SEG1	
1 Indoor Unit Capacity	CR	00 ^{*1)}	Unit Capacity Indication Refer to "Indoor Unit Capacity Table".
2 Expansion Valve Opening	1E	00	Unit: %
3 Heat Exchanger Liquid Piping Temp.	FL	00	Unit: °C
4 Heat Exchanger Gas Piping Temp.	FG	00	Unit: °C
5 Air Inlet Temp.	Fi	00	Unit: °C
6 Air Outlet Temp.	Fo	00	Unit: °C
7 Unit Stoppage Cause Code	d1	00	Indoor Unit Stoppage Cause Code Indication Refer to "Cause of Indoor Unit Stoppage Table".

(Example)
SEG2 SEG1

*1): The indoor unit No. is indicated on the one digit of "SEG1".

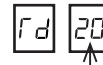

● Indoor Unit Capacity Table

Indication	Capacity (kW)	Horsepower (HP)	Indication	Capacity (kW)	Horsepower (HP)	Indication	Capacity (kW)	Horsepower (HP)
6	22	0.8	16	56	2.3	40	140	5.0
8	28	1.0	18	63	2.5	48	160	6.0
10	36	1.3	20	71	2.8	64	224	8.0
11	40	1.5	22	80	3.0	80	280	10.0
13	45	1.8	26	90	3.3	128	450	16.0
14	50	2.0	32	112	4.0	160	560	20.0

(D) Cause of Alarm Code Information

This information is indicated on the unit A (main unit) only.
 Press PSW4 (▼) to forward of press PSW2 (▲) for backward.
 The information will be indicated alternately as "Item" → "Details".

Details of Indication

	Item	7-Segment Display		Details
		SEG2	SEG1	
1	Alarm Cause Code		AC	Latest O.U. Stoppage Alarm Code Indication Refer to "Alarm Code Table".
2	Degeneracy Control for Pressure Ratio Decrease Protection	C	11	□: Degeneracy Control is not Activated. : Degeneracy Control is Activated.
3	Degeneracy Control for Pressure Ratio Increase Protection	C	13	□: Degeneracy Control is not Activated. : Degeneracy Control is Activated.
4	Degeneracy Control for Inverter Fin Temp. Increase Protection	C	14	□: Degeneracy Control is not Activated. : Degeneracy Control is Activated.
5	Degeneracy Control for Discharge Gas Temp. Increase Protection	C	15	□: Degeneracy Control is not Activated. : Degeneracy Control is Activated.
6	Degeneracy Control for Td SH Decrease Protection	C	16	□: Degeneracy Control is not Activated. : Degeneracy Control is Activated.
7	Degeneracy Control for Overcurrent Protection	C	17	□: Degeneracy Control is not Activated. : Degeneracy Control is Activated.

(E) Alarm Code History Information

This information is indicated on the unit A (main unit) only.
 If history of abnormality exists, it is indicated maximum 15 cases in chronological order.
 Press PSW4 (▼) to forward of press PSW2 (▲) for backward.

Select the data No. for indication by pressing PSW4 or PSW2.
 Press PSW3(▶) for details information.
 Press PSW4(▼) to forward or PSW2(▲) to backward.
 Press PSW5(◀) for return to Combination Unit No. Selection.

Data No.	7-Segment Display	
	SEG2	SEG1
1 (Latest Data)	no	01
↓	↓	↓
15 (Oldest Data)	no	15

Details of Indication

	Item	7-Segment Display		Details
		SEG2	SEG1	
1	Unit Accumulated Operation Time	07	08	O.U. Accumulated Operation Time at Stoppage Unit: Hour (Indication x 10 Hours)
2	Cause of Stoppage	AC		Alarm Stoppage
		d1		Retry Stoppage
		C1		Control Information
3	Alarm/Stoppage Cause Code	01	48	Alarm and Stoppage Cause Code O.U. No. is indicated on 10 digit of SEG2. Compressor and fan controller No. are indicated on one digit of SEG2. Alarm and stoppage code are indicated on SEG1.
4	Alarm Data Indication	1F	12	Inverter stoppage cause code is indicated when IT code is existing on SEG2.
		FF	12	Fan controller stoppage cause code is indicated when FT code is existing on SEG2.
		CF	0	Stoppage cause of constant speed compressor abnormal current is 0A stoppage.
		CF	FF	Overcurrent Stoppage of Constant Speed Compressor
		--	--	Except for the above

(7) Running Current of Compressor

- Inverter Primary Current

The inverter primary current is estimated from the running current of the compressor MC1 indicated on 7-segment.

- Indicated Running Current of Compressor MC2

The running current of the compressor MC2 is detected by current sensor. (CT2)

- Cause of Inverter Stoppage (Check Item “*i*”)

Code	Cause
1	IPM Error (Overcurrent, Decrease Voltage, Short Circuit)
2	Instantaneous Overcurrent
3	Abnormal Inverter Fin Temperature
4	Inverter Overcurrent
5	Inverter Voltage Decrease
6	Inverter Voltage Increase
7	Abnormal Inverter Transmission
8	Abnormal Current Sensor
9	Instantaneous Power Failure Abnormal Power Source Phase
11	Micro Computer Reset
12	Earth Fault Detecting
13	Abnormal Power Source Phase
16	Inverter Failure
21	Abnormal Start-up

- Cause of Fan Controller Stoppage (Check Item “*F*”)

Code	Cause
1	Driver IC Error
2	Instantaneous Overcurrent
3	Abnormal Inverter Fin Temperature
4	Inverter Overcurrent
5	Fan Controller Voltage Decrease
6	Fan Controller Voltage Increase
7	Abnormal Fan Controller Transmission
8	Abnormal Current Sensor
9	Instantaneous Power Failure
11	Micro Computer Reset
12	Earth Fault Detecting
15	Reverse Rotation
16	Fan Controller Retry
17	Abnormal Control
21	Abnormal Start-up

1.2.5 Function of RSW, DSWs and LEDs

Arrangement Inside of Electrical Box

- AVWT-76~114HKFXE

Front Side (Main)

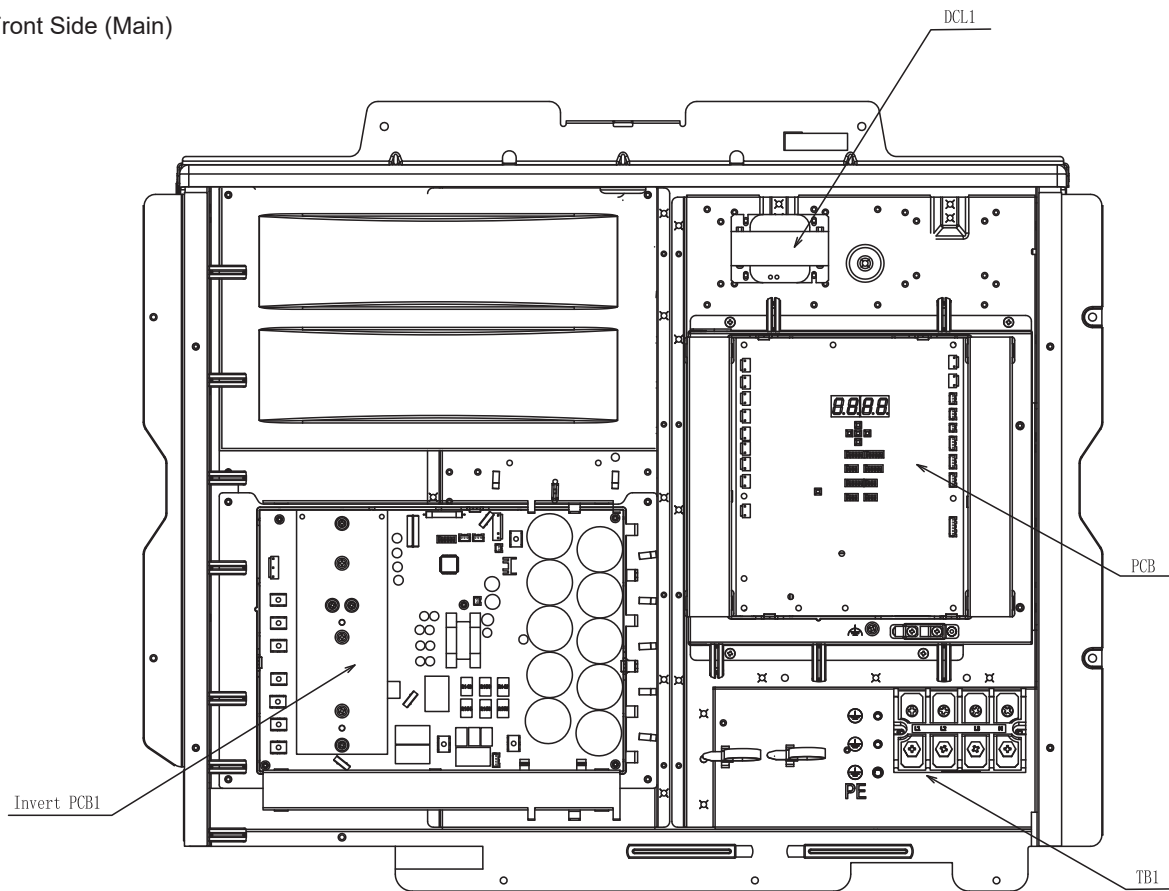

Interior of Electrical Control Box (Main)

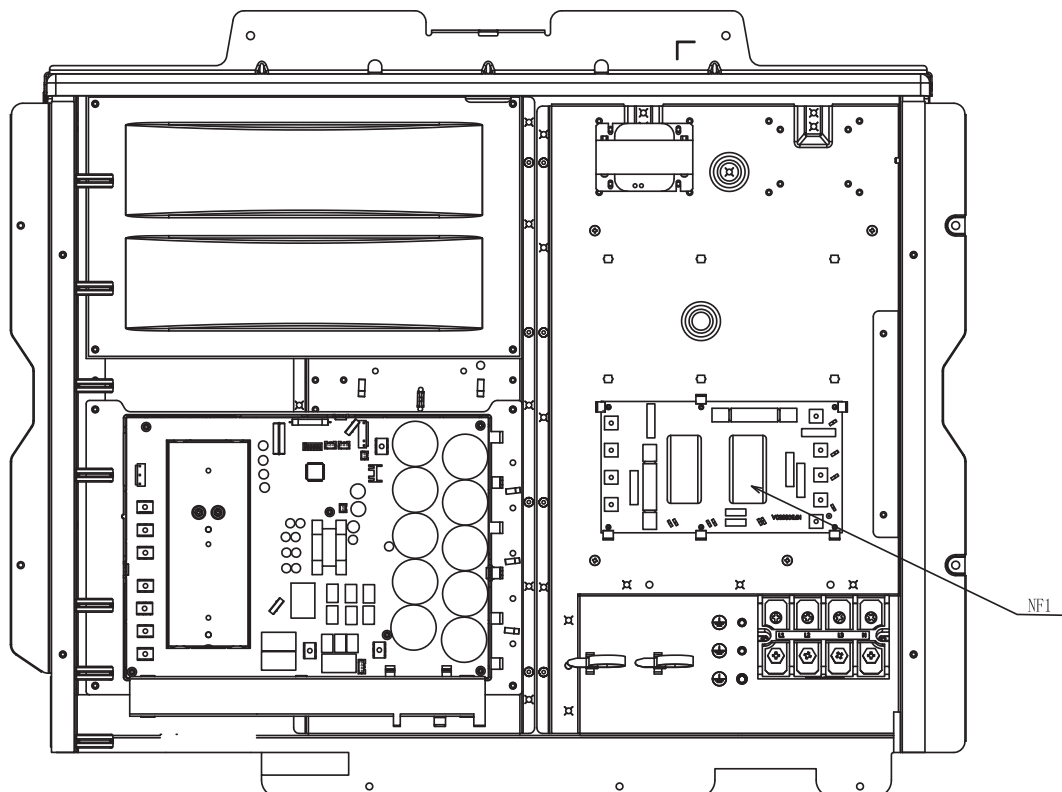

- AVWT-136~170HKFXE

Front Side (Main)

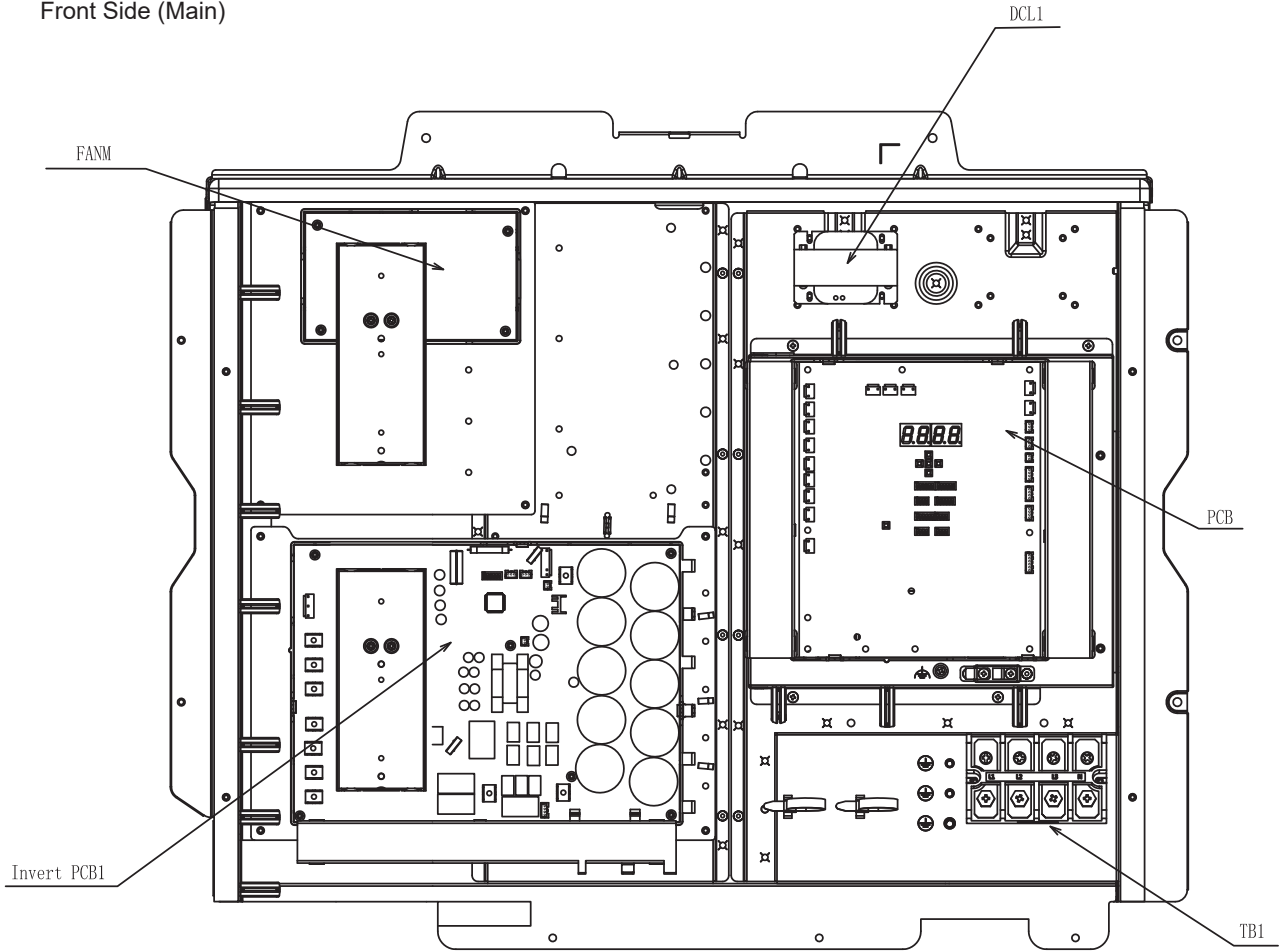

Interior of Electrical Control Box (Main)

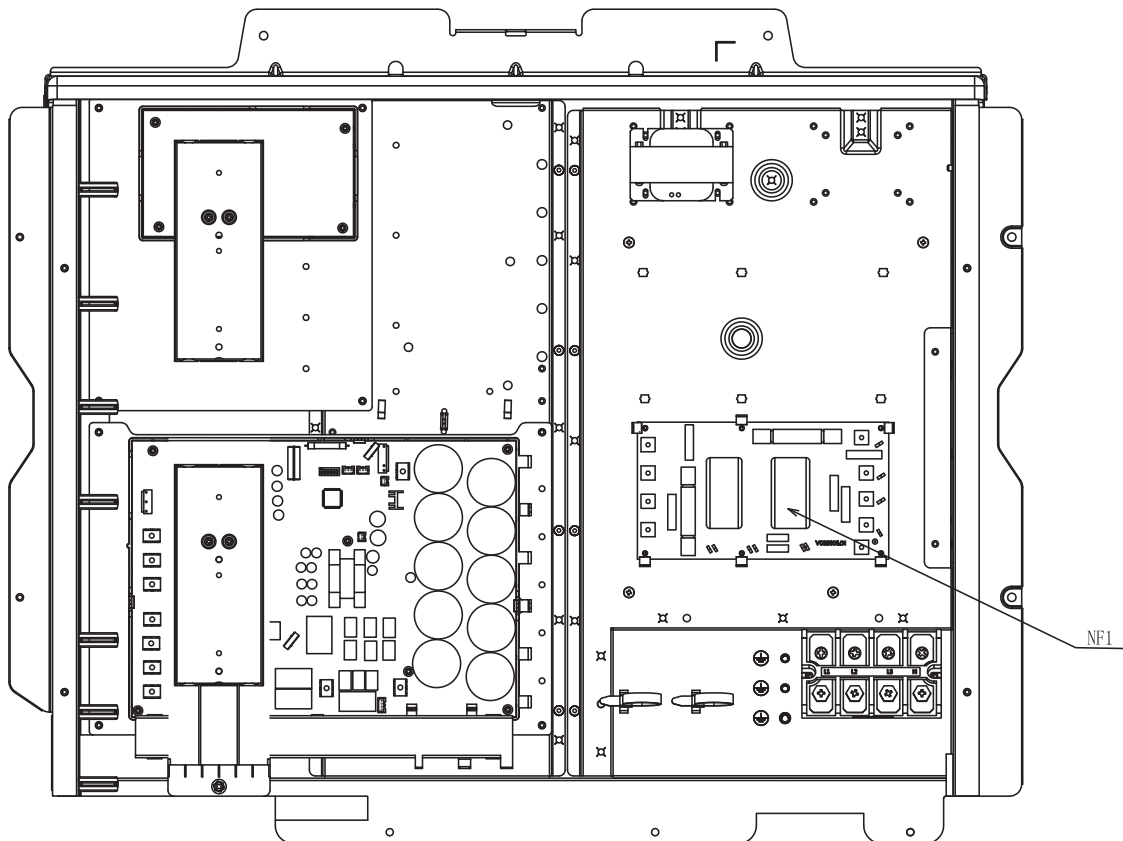

- AVWT-190~272HKFXE

Front Side (Main)

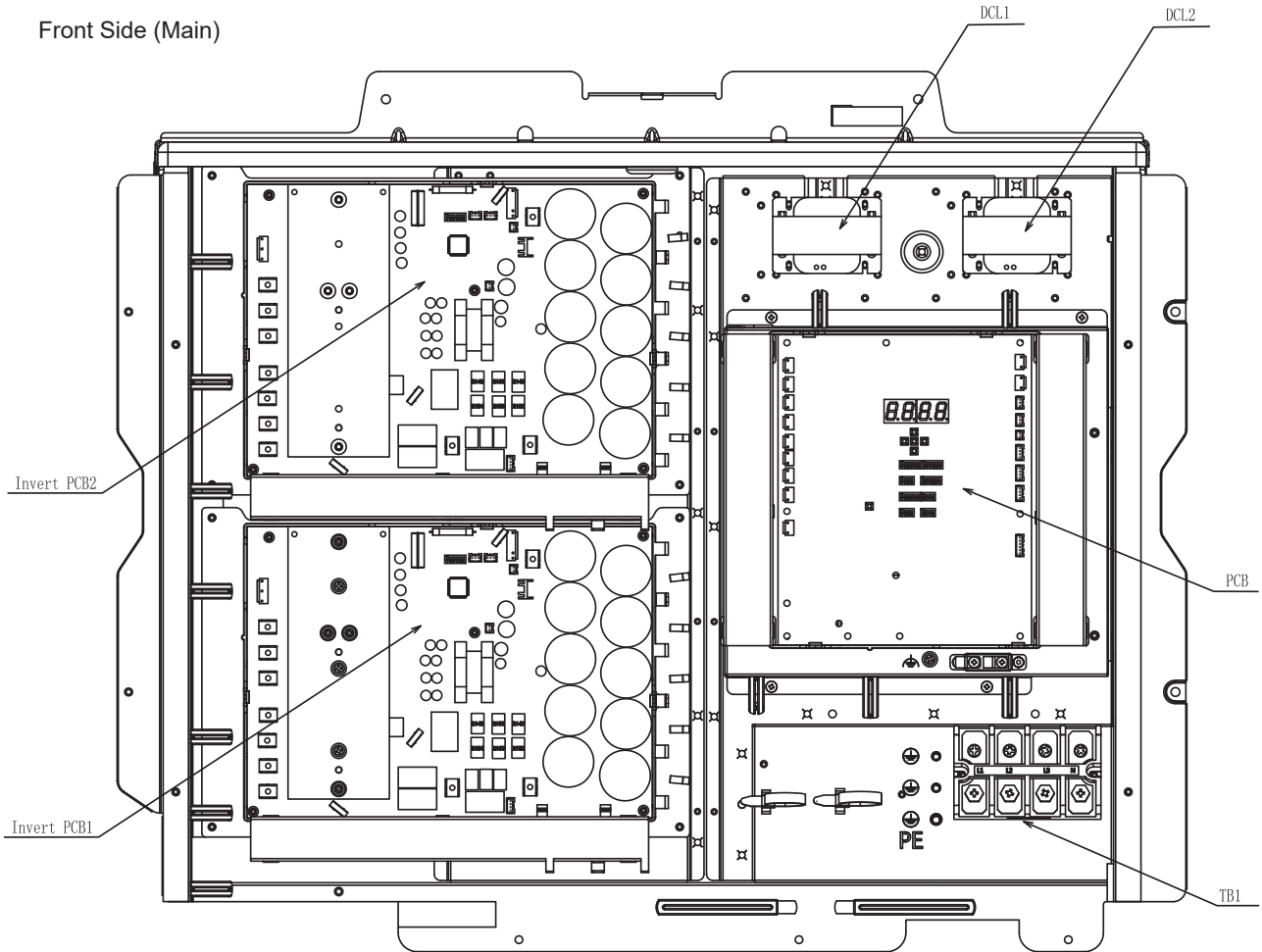

Interior of Electrical Control Box (Main)

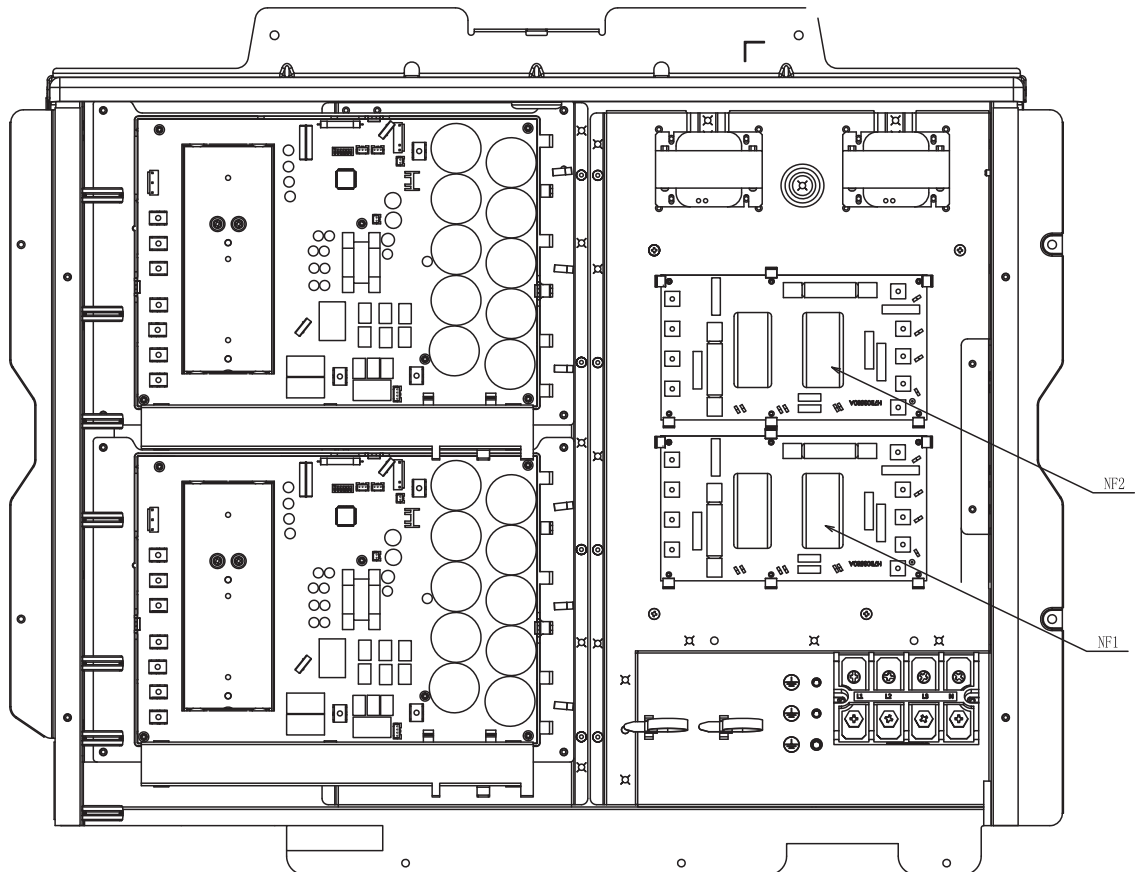

■ LEDs and SEGs on PCB

Part Name	Contents of Functions
LEDs	LED1 (Red) Power Source Indication for Outdoor Unit PCB (Low Voltage) Normal Condition: Activated Abnormal Condition: Deactivated"
	LED2 (Green) This LED2 indicates the transmission state between the outdoor unit PCB and inverter PCB. Normal Condition: Flashing Abnormal Condition: Activated or Deactivated"
	LED3 (Yellow) This LED3 indicates the transmission state between the indoor unit and outdoor unit. Normal Condition: Flashing Abnormal Condition: Activated or Deactivated"
	LED4 (Orange) This LED4 indicates the transmission state between the outdoor units. Normal Condition: Flashing Abnormal Condition: Activated or Deactivated"
	LED7 (Red) Power Source Indication for Outdoor Unit PCB (High Voltage) Normal Condition: Activated Abnormal Condition: Deactivated"
SEGs	SEG1, SEG2 These indicate the following "Alarm", "Protective Safety Device has Tripped" or "Checking Items".

■ Dip Switch Setting of Outdoor Unit

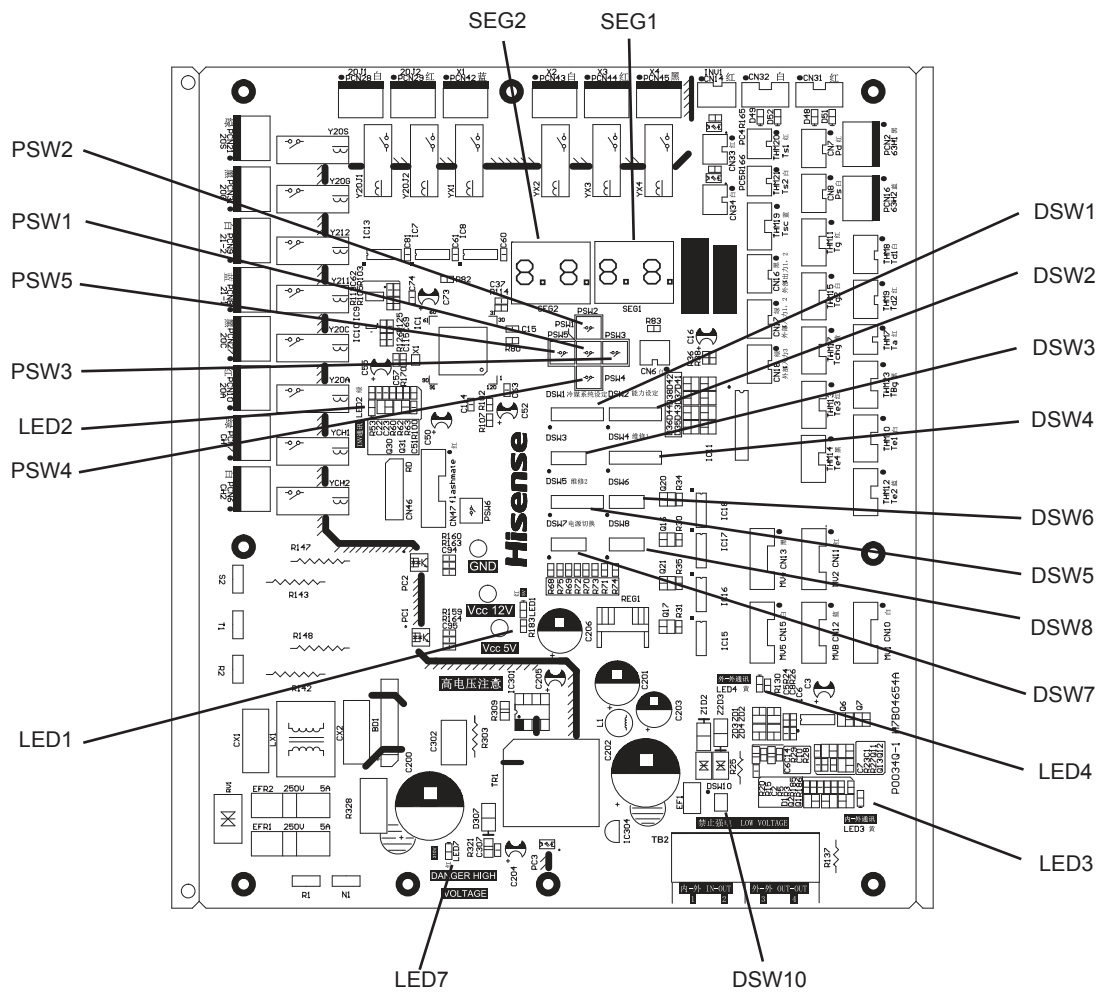

■ Procedure of Checking Inverter PCB

<Procedure>

- (a) Turn OFF the main switches and wait for three minutes. Check to ensure that no high voltage exists. If LED3 is ON after start-up and LED3 is OFF after turning OFF power source, the voltage will decrease lower than DC50V.
- (b) Connect connecting wires to an electrical solder bit.
- (c) Connect the wires to terminals, DCL2 and N1 on Inverter PCB. => Discharging is started, resulting in hot solder bit. Pay attention not to short-circuit between terminal DCL2 and N1. (d) Wait for 2 or 3 minutes and measure the voltage once again. Check to ensure that no voltage is charged.

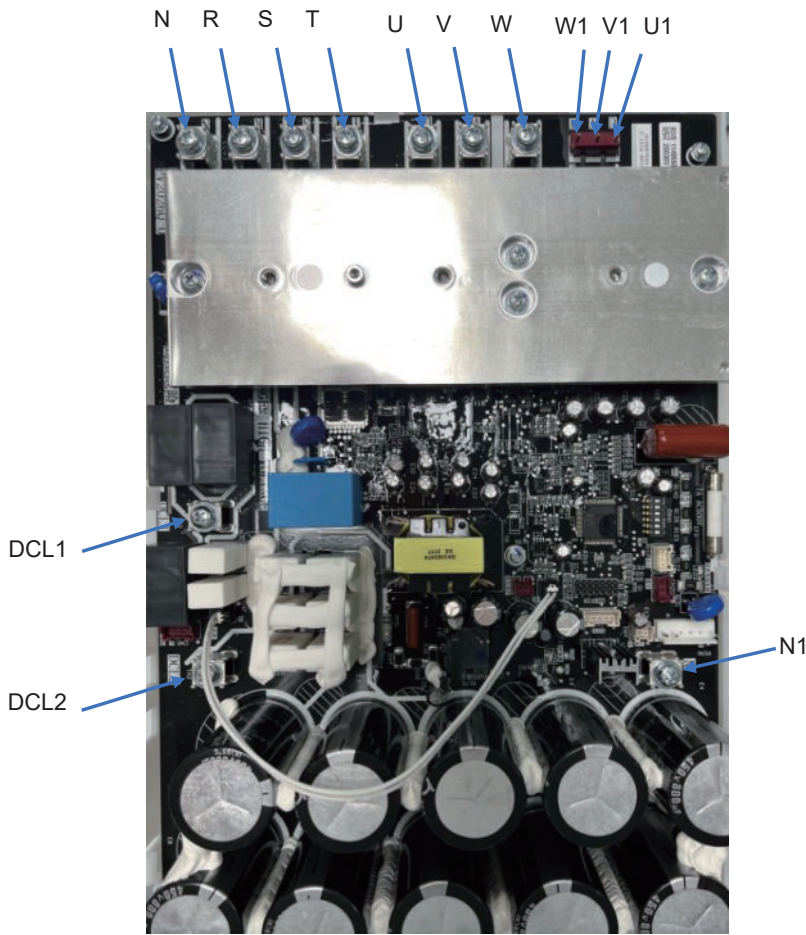

Tester Probe Red (+) - Black (-)	Resistance Range
P - R P - S P - T R - N S - N T - N	Over 80MΩ
R - P S - P T - P N - R N - S N - T DCL2 - U DCL2 - V DCL2 - W DCL2 - U1 DCL2 - V1 DCL2 - W1 U - N1 V - N1 W - N1 U1 - N1 V1 - N1 W1 - N1 U - DCL2 V - DCL2 W - DCL2 U1 - DCL2 V1 - DCL2 W1 - DCL2 N1 - U N1 - V N1 - W N1 - U1 N1 - V1 N1 - W1"	1~6MΩ
DCL2 - N1	1~20K

■ Procedure of Checking Fan Controller

<Procedure>

(a) Turn OFF the power source switches before this work.

Also ensure that LED501 (Red) on the fan controller is turned OFF. If LED501 is ON, electric shock may occur.

(b) Disconnect all the wirings connected to the fan controller.

Measure the resistance between terminals using the tester. (Do not use a digital tester.)

When measuring, check the color of tester probe and the terminals to be measured as shown in the table below.

Tester Probe Red (+) - Black (-)	Resistance Range
P - U P - V P - W U - N V - N W - N	over 500MΩ
U - P V - P W - P N - U N - V N - W	Resistance will gradually increase once after it is between 1kΩ to 6MkΩ. (*)

(*) Leave at least 30 seconds when measuring the next terminals.



< DSW Initial Setting >

DSW1			
1	2	3	4
OFF	ON	OFF	OFF

Regarding DSW setting, do not change from the original setting. Abnormal transmitting and fan controller failure may occur if the setting is changed.

■ Checking Method of Electronic Expansion Valve

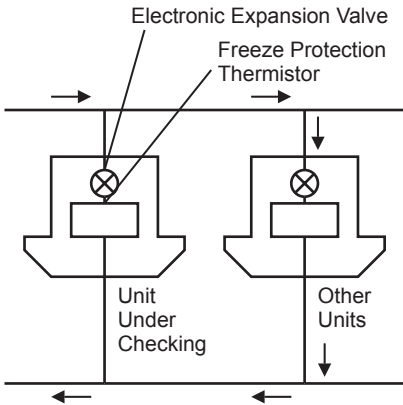
	Indoor Unit Electronic Expansion Valve	Outdoor Unit Electronic Expansion Valve
Locked (Fully Closed)	Check for the liquid pipe temperature during heating operation. It is abnormal if the temperature does not increase.	It is abnormal if the liquid pipe pressure does not increase during cooling operation
Locked (Slightly Open)	It is abnormal under the following conditions; The temperature of freeze protection thermistor becomes lower than the suction air temperature when the unit under checking is stopped and the other units are in cooling operation.	It is abnormal if the liquid pipe pressure does not increase and the outlet temperature of the expansion valve decreases after the cooling operation is started.
Locked (Fully Open)		It is abnormal under the following conditions; After heating operation for more than 30 min., the discharge gas temperature of compressor is not 10°C higher than the condensing temperature and there is no other faults such as excessive charge of refrigerant, etc.

■ Checking of Electrical Coil Parts

Name of Parts	Model	Electrical Wiring Diagram	Wiring No.	Resistance (Ω)
DC Fan Motor for Outdoor Unit AVWT-76~114HKFXE AVWT-190~272HKFXE	L-QH-750-M4-1 750W		White-Black Black-Red Red-White	9.42±0.942
DC Fan Motor for Outdoor Unit AVWT-136~170HKFXE	ZWF-750G 750W		White-Black Black-Red Red-White	8.6±1.0

Name of Parts	Model	Resistance (Ω)
Compressor Motor for Outdoor Unit AVWT-76/96/190HKFXE	ATH550SKRC8FQP	0.426 at 20°C
Compressor Motor for Outdoor Unit AVWT-114/212/232HKFXE	ATE650SKTQ9JKP	0.278 at 20°C
Compressor Motor for Outdoor Unit AVWT-136/154/250/272HKFXE	ATE848SKTQ9JKP	0.278 at 20°C

■ Checking of Compressor

CHECK LIST ON COMPRESSOR

CLIENT: _____

MODEL: _____

DATE: _____

Serial No.: _____

Production Date: _____

Checker: _____

No.	Check Item	Check Method	Result	Remarks
1	Are THM8 and THM9 correctly connected? THM8 and THM9: Discharge Gas Thermistor"	(1) Are wires of each thermistor correctly connected by viewing? (2) Check to ensure that 7-segment indication of Td1 is higher than Td2 when No.1 comp. is operating. Td1: Temperature of THM8 Td2: Temperature of THM9"		
2	Are thermistor, THM8 and THM9 disconnected?	(1) Check to ensure that thermistor on the top of comp. is correctly mounted by viewing? (2) Check to ensure that actually measured temp. are greatly different from the indication (Td1, Td2) during check mode."		
3	Is current sensor faulty?	(1) Check to ensure that 7-segment indication A1 and A2 are 0 during compressor stopping. (2) Check to ensure that indication A1 and A2 are not 0 during compressor running. (However, A2 is 0 during stopping of No.2 comp.)		
4				
5	Is current sensing part on inverter PCB faulty?			
6	Are the wires to compressor correct?	Check the compressor wires		
7	Are power source wires, U / V / W inserted correctly into terminals?	Check to ensure that wires are correctly inserted.		
8	Are expansion valves (MV1 / MVB) correctly connected?	Check to ensure that MV1 to CN10 / MVB to CN12 are correctly connected.		
9	Are expansion valve coils (MV1 / MVB) correctly mounted?	Check to ensure that each coil is correctly mounted on the valve.		
10	Are the refrigeration cycle and electrical wiring system incorrectly connected?	Check to ensure that refrigerant is flowing into indoor units by operating one refrigerating cycle only from the outdoor unit.		
11	Is opening of expansion valve completely closed (locked)?	Check the followings by the check mode of outdoor units. (1) Liquid Pipe Temp. (TL) < Air Intake Temp. (Ti) during Cooling Operation (2) Liquid Pipe Temp. (TL) > Air Intake Temp. (Ti) during Heating Operation"		
12	Is opening of expansion valve fully opened (locked)?	Check to ensure that liquid pipe temp. is lower than air intake temp. of stopping indoor unit when the other indoor units are operating under cooling operation.		
13	Are the contacts for comp. magnetic switch RY2/3 ON inverter PCB faulty?	Check the surface of each contact by viewing.		
14	Is there any voltage abnormality among L1-L2, L2-L3 and L3-L1?	Check to ensure that voltage imbalance is smaller than 3%. Please note that power source voltage must be within 415V or 380V or 4600V±10%.		
15	Is the comp. oil acidified during compressor motor burning?	Check to ensure that the oil color is not black.		

Additional Information for "CHECK LIST ON COMPRESSOR

Check Item	Additional Information (Mechanism of Compressor Failure)
1 & 2	The liquid refrigerant return volume to the compressor is controlled by the discharge gas temperature Td1 when only No.1 compressor is operating. If Td1 and Td2 are reversely connected, the liquid refrigerant return volume will become smaller by detecting the temperatures even if the actual discharge gas temperature is high. Therefore, this abnormal overheating operation will result in insulation failure of the motor winding.
3, 4 & 5	Overcurrent control (operating frequency control) is performed by detecting current by the current sensor. In this case, winding insulation failure will occur, since control is not available in spite of actually high current.
6 & 7	The current sensor checks phase and adjusts output electrical wave in addition to the above mentioned items. If fault occurs, the output electrical wave becomes unstable giving stress to the motor winding, resulting in winding insulation failure.
8 & 9	During a cooling operation, Pd is controlled by fan revolution of outdoor unit, and Td and SH are controlled by MV of each indoor unit. During a heating operation, Td and SH are controlled by MV1. If expansion valves are incorrectly connected, correct control is not available, resulting in compressor seizure depending on liquid refrigerant returning conditions or motor winding insulation failure depending on overheating conditions."
10	If the refrigeration cycle and electrical system are incorrectly connected, abnormally low suction pressure operation is maintained or abnormally high discharge pressure operation is maintained, resulting in giving stress to the compressor, since their correct control is not available.
11	ditto
12	The compressor may be locked due to the liquid return operation during the cooling operation.
13	In the case that the contacting resistance becomes big, voltage imbalance among each phase will cause abnormal overcurrent.
14	In this case, overcurrent will occur, efficiency will decrease or the motor winding will be excessively heated.
15	In the case, it will result in motor burning or compressor seizure.

2. Servicing

! DANGER

Use the specified non-flammable refrigerant (R410A) to the outdoor unit in the refrigerant cycle. Do not charge materials other than R410A into the unit such as hydrocarbon refrigerants (propane or etc.), oxygen, flammable gases (acetylene or etc.) or poisonous gases when installing, maintaining and moving the unit. These flammables are extremely dangerous and may cause an explosion, fire, and injury.

! WARNING

TURN OFF all power source switches.

2.1 Removing Front Service Cover

- (1) Removing Service Cover
 - (a) Remove four (4) screws fixing in the service cover.
 - (b) Put your hands on the groove at the bottom of the service cover. Then, lift the cover slightly and draw it forward.
- (2) Removing Front Cover
 - (a) Front cover shall be removed after removing the service cover. Remove seven (7) screws fixing in the front cover.
 - (b) Hold the upper side of the front cover and lift it obliquely upward. Do not remove the screw in Fig. 1.
- (3) Removing Piping Cover
 - Piping cover shall be removed after removing the front cover. Remove the screw in Fig. 1 and lift the piping cover obliquely upward.

NOTE:

When attaching / removing the front service cover, take special care not to be injured with the plate edges.

Tool	Phillips Screwdriver
------	----------------------

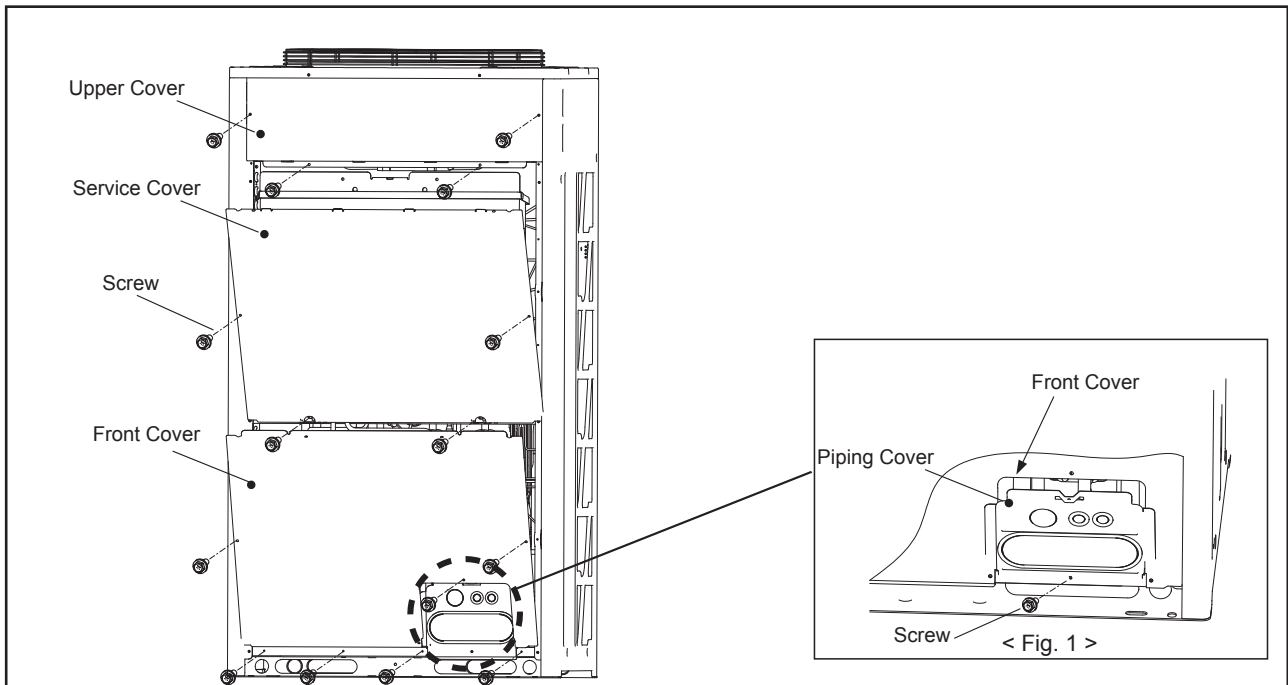

! WARNING

TURN OFF all power source switches.

2.2 Attaching Front Service Cover

(1) Attaching Piping Cover

- (a) Put the piping cover 45° obliquely (Refer to Fig.1), then insert the hook of the piping cover into the edge of the floor cover. (Refer to Fig. 1)
- (b) Vertical the piping cover and fix the front cover with the screw in Fig. 2.

Tool	Phillips Screwdriver
------	----------------------

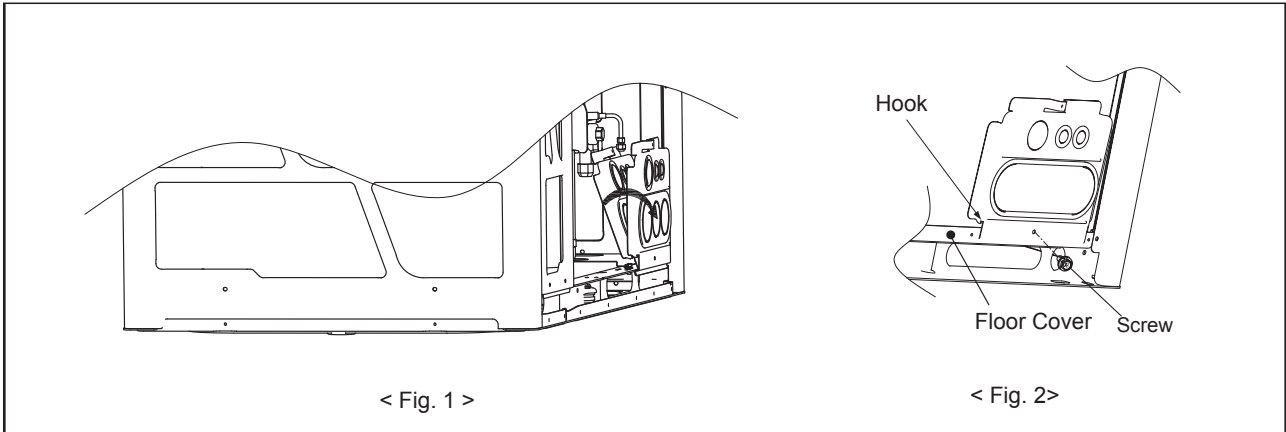

(2) Attaching Front Cover

- (a) Service cover shall be attached after attaching the piping cover.
- (b) Fix the front cover with the screws.

(3) Attaching Service Cover

- (a) Service cover shall be attached after attaching the front cover and upper cover. Insert the hooks of the service cover into the square holes of the upper cover. (Refer to Fig. 3)
- (b) Fix the front cover with the screws.

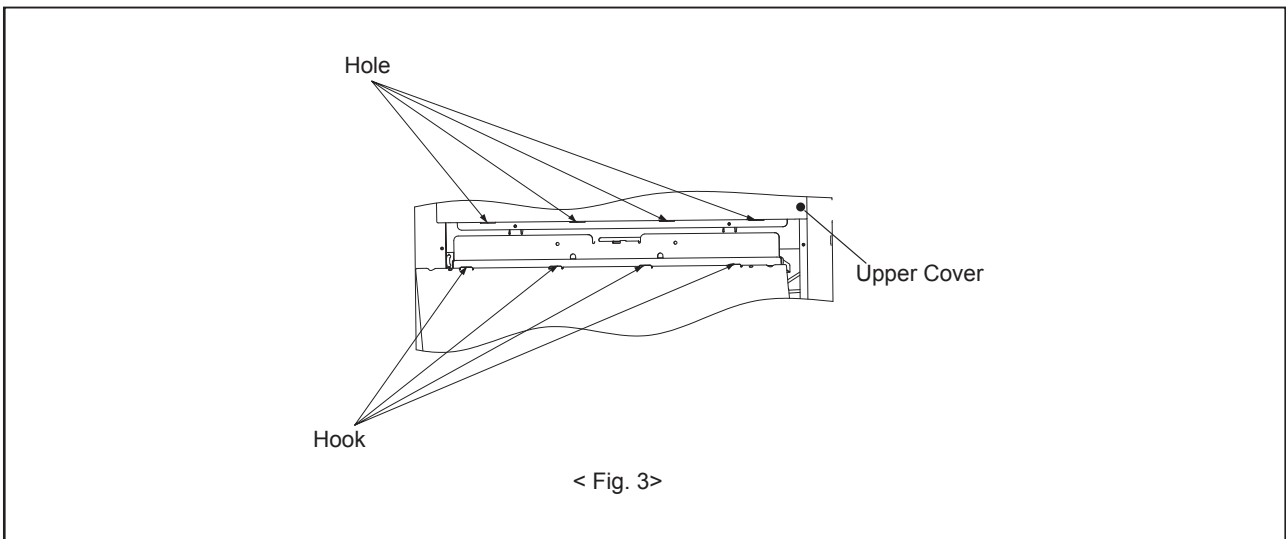

! WARNING

TURN OFF all power source switches.

2.3 Removing Top Cover

- (1) Remove screws fixing in the top cover.
AVWT-76~114HKFXE: 8 screws
AVWT-136~272HKFXE:10 screws
- (2) Lift the top cover up.

Tool	Phillips Screwdriver
------	----------------------

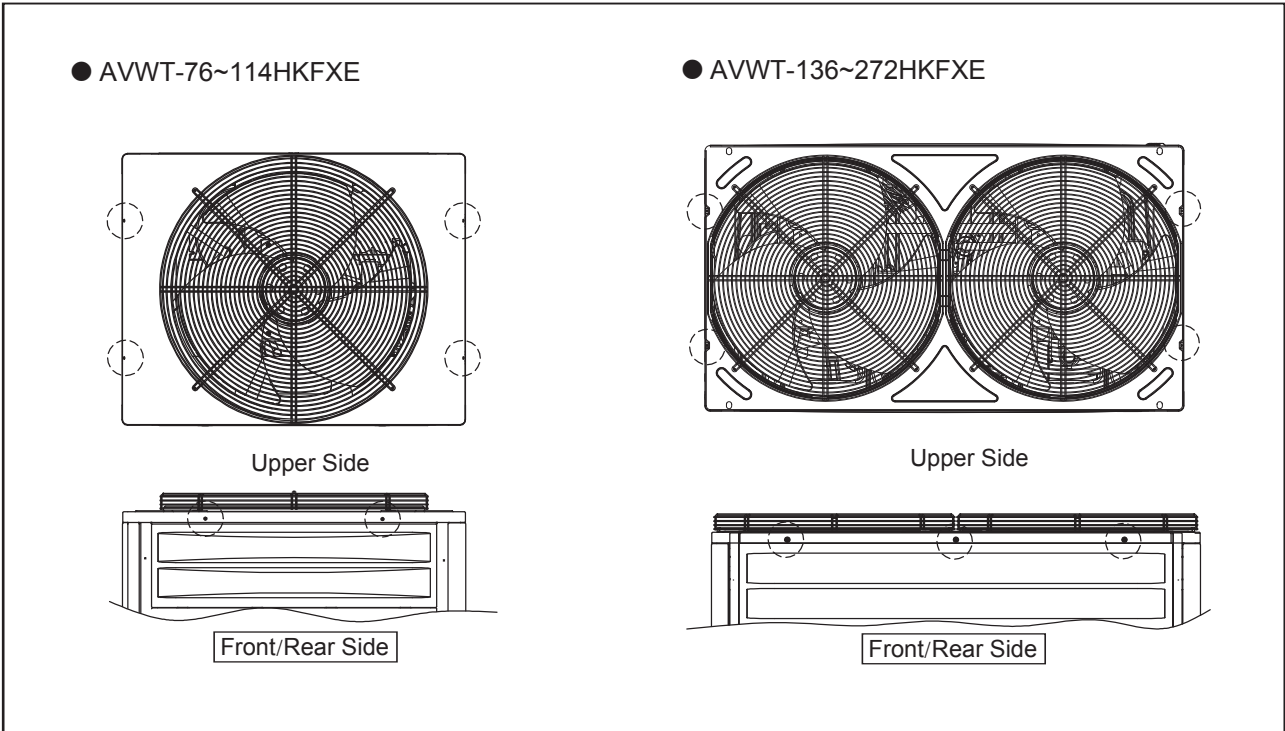

! WARNING

TURN OFF all power source switches.

2.4 Removing Shroud

- (1) Remove the top cover according to the item 2.3 "Removing Top Cover".
- (2) Remove the service cover according to the item 2.1 "Removing Front Service Cover".
- (3) Remove screws fixing the upper cover and then lift the upper cover up.
 AVWT-76~114HKFXE: 4 screws
 AVWT-136~272HKFXE: 5 screws

Tool	Phillips Screwdriver
------	----------------------

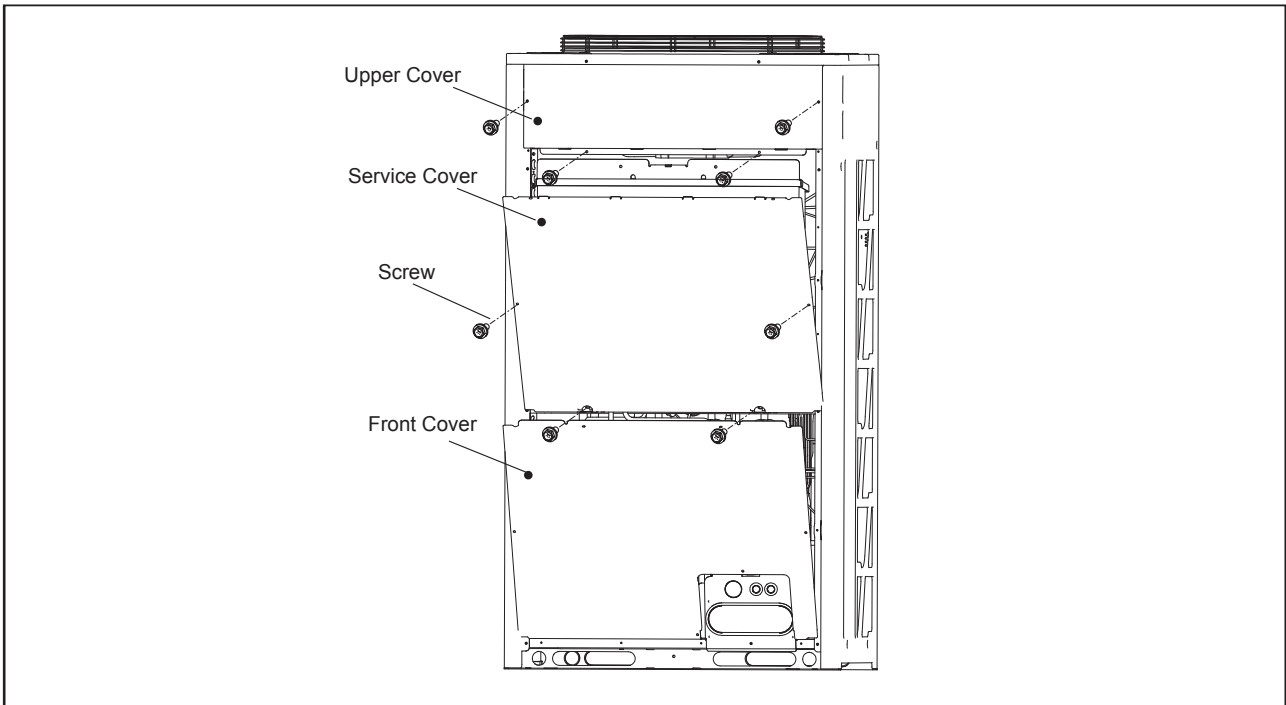

- (4) Remove screws fixing the shroud and then lift the shroud up.
 AVWT-76~114HKFXE: 10 screws.
 AVWT-136~272HKFXE: 20 screws.

Tool	Phillips Screwdriver
------	----------------------

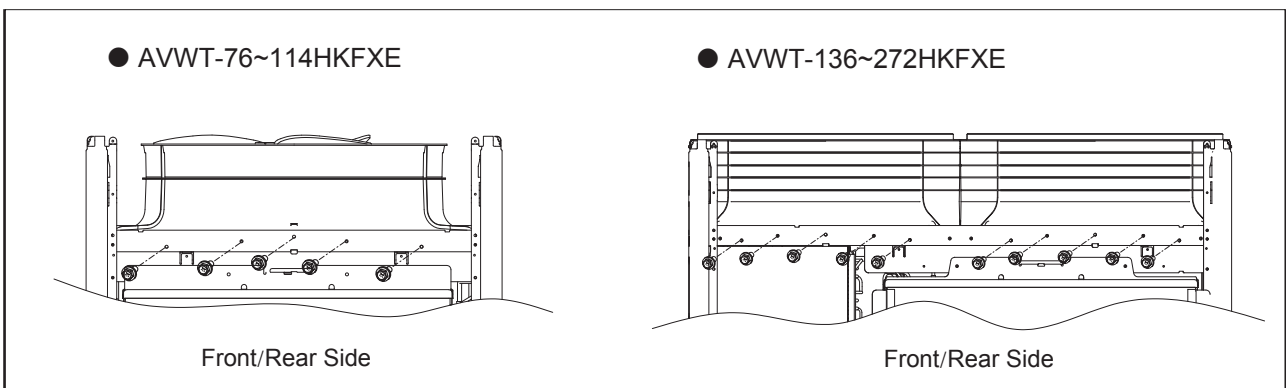

- (5) After repaired, reset the machine in reverse order.

NOTE:

When attaching / removing the shroud, make sure that it dose not contact the propeller fan.

! WARNING

TURN OFF all power source switches.

2.5 Removing Electrical Box Cover

- (1) Remove the front service cover according to the item 2.1 "Removing Front Service Cover".
- (2) Remove two (2) screws fixing in the electrical box cover and loosen the other two (2) fall-prevention screws.
- (3) Push the electrical box cover up and draw it frontward from the fall-prevention screws.

NOTE:

- Before removing the screws fixing in the electrical box cover, check that the fall-prevention screws are attached to the cover in order to prevent the electrical box cover from dropping off.
- Take special care not to be injured with the front cover edges when removing the electrical box cover.

Tool	Phillips Screwdriver
------	----------------------

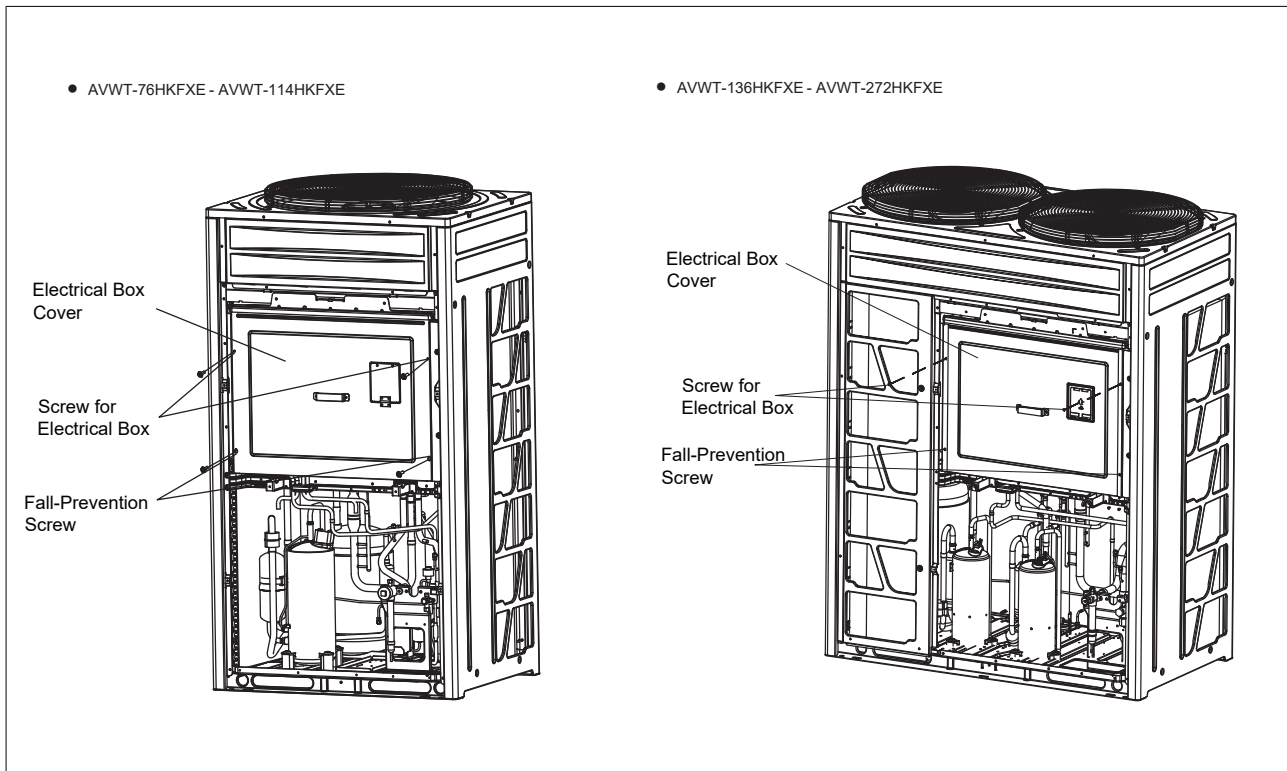

! WARNING

TURN OFF all power source switches.

2.6 Removing Electrical Box

- (1) Remove the service cover and front cover according to the item 2.1 "Removing Front Service Cover".
- (2) Remove the electrical box cover according to the item 2.4 "Removing Electrical Box Cover".
- (3) Remove the M5 bolts (3 for single fan, 6 for dual fan) in position ① (Refer to Fig. 1);
- (4) Remove the two M5 screws in position ②, (Refer to Fig. 1), and remove the rubber block and fixed sheet metal;
- (5) Remove the screws around the electrical box.
- (6) Pull the refrigerant cooling module 15~20 degrees forward (Refer to Fig. 2);
- (7) Turn the electrical box clockwise until the right side of the box is completely outside the machine (Refer to Fig. 2);
- (8) Move the electrical box to the right until the electrical box is completely outside the machine (Refer to Fig. 2);
- (9) After repair, reset the machine in reverse order, and the refrigerant cooling module should be in close contact with inverter to facilitate heat transfer when reinstalled.

NOTE:

- Before removing the electrical box, make sure that all connections to the electrical box have been completely removed.
- As the electrical box is heavy, it requires at least two persons wearing gloves and other protective gear for removal and installation.

* When resetting the refrigerant cooling module, please follow the tightening torque requirements of the M5 screws:
 Primary pre-tightening torque:1.3N.m; Secondary tightening torque: 3N.m.

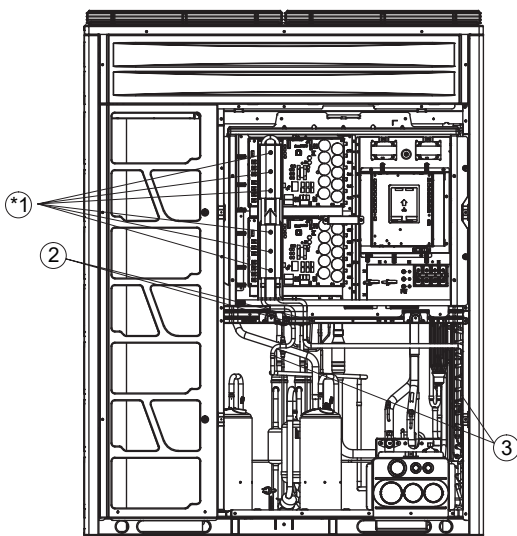

Fig.1

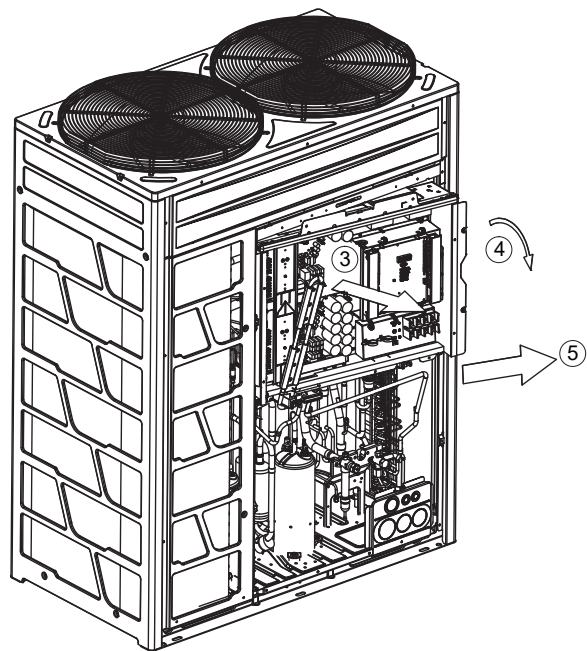

Fig.2

! WARNING

TURN OFF all power source switches.

2.7 Removing E-Box Stay

- (1) Remove the electrical box according to the item 2.6 "Removing Electrical Box".
- (2) Remove the screws fixing in the E-Box stay.

AVWT-76~272HKFXE: 4 screws

The position of the screws can be seen in the figures below.(Example: AVWT-76HKFXE)

Lift the E-Box stay up. Remove the the hooks of E-Box stay from the holes on the right and left sides (Refer to Fig. 2).

Tool	Phillips Screwdriver
------	----------------------

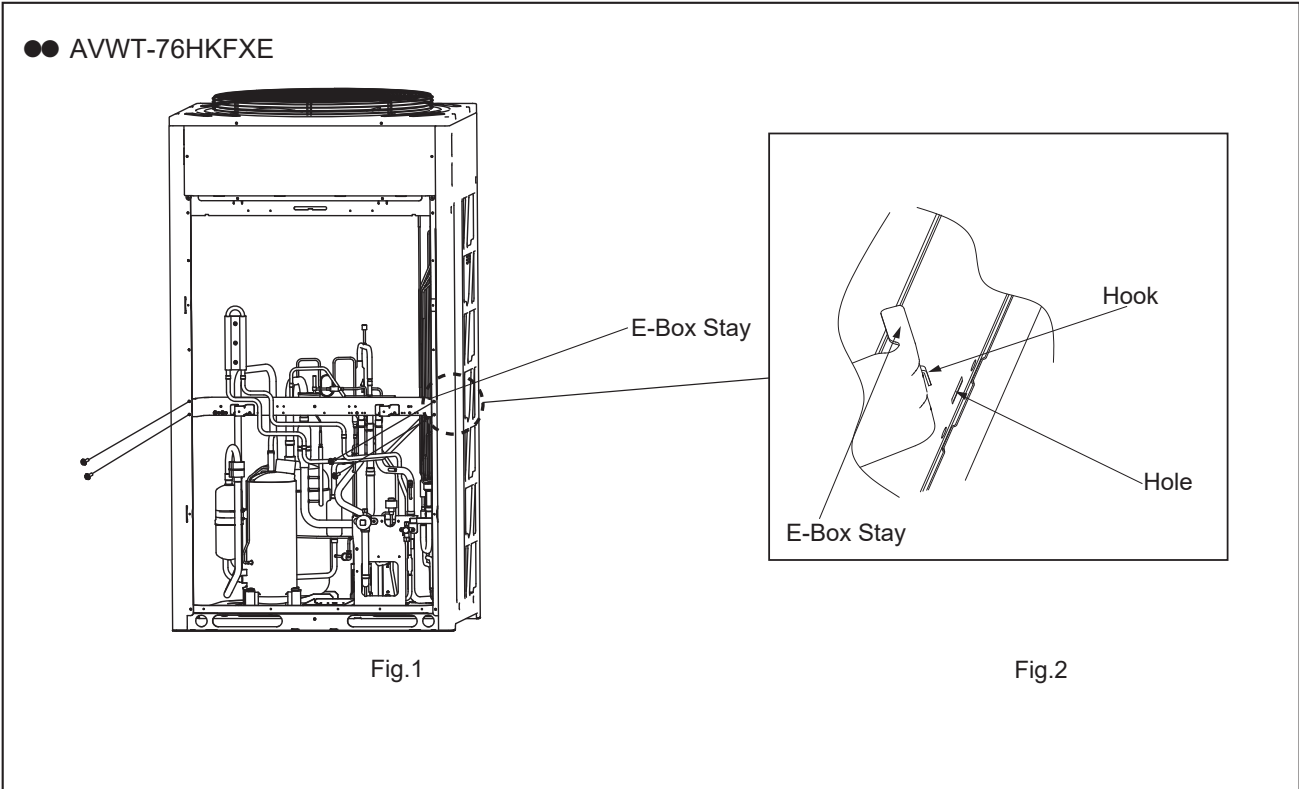

! WARNING

TURN OFF all power source switches.

2.8 Removing Air Grille

- (a) Remove the screws (4 for single fan, 8 for double fan) fixing in the air grille.
- (b) Remove the air grille.

Tool	Phillips Screwdriver
------	----------------------

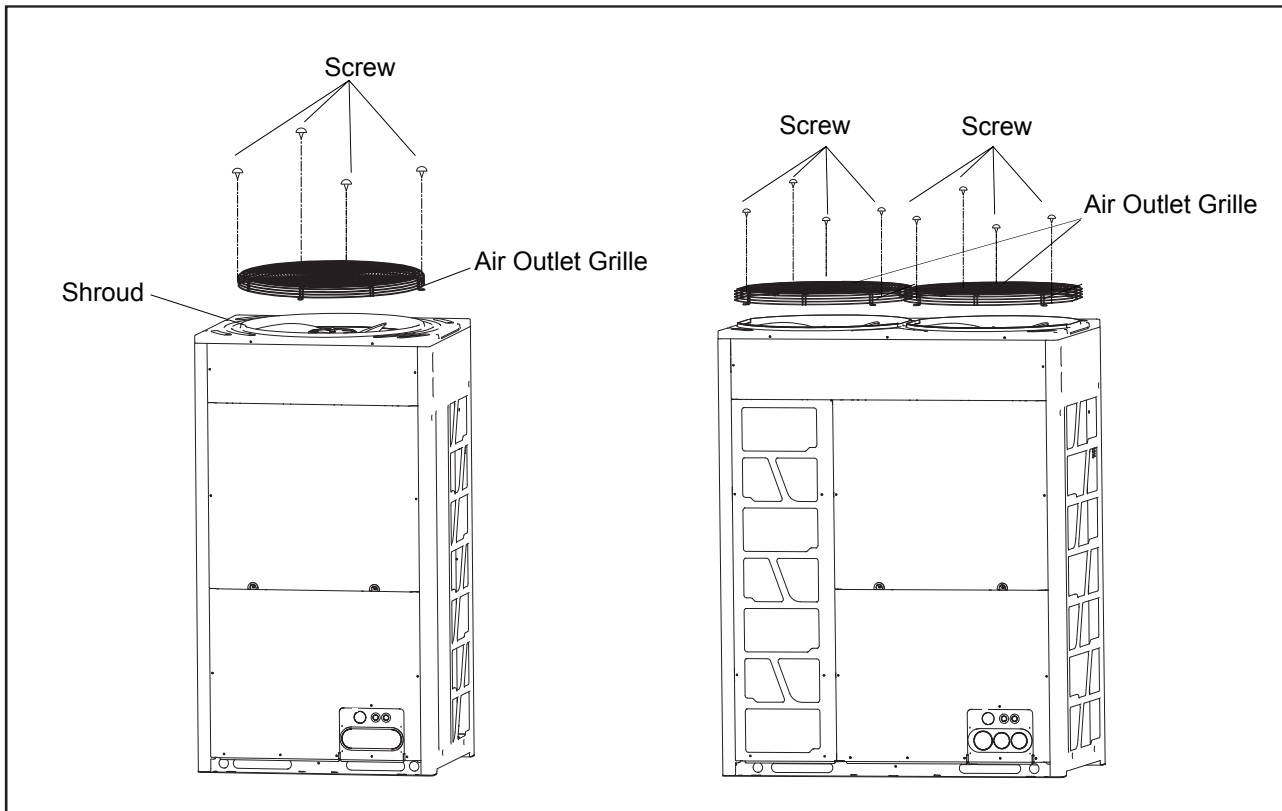

! WARNING

TURN OFF all power source switches.

2.9 Removing Outdoor Fan

(1) Remove the air grille according to the item 2.8 "Removing Air Grille".

Tool	Adjustable Wrench, Spanner, Puller, Phillips Screwdriver, Nippers, Box Wrench
------	---

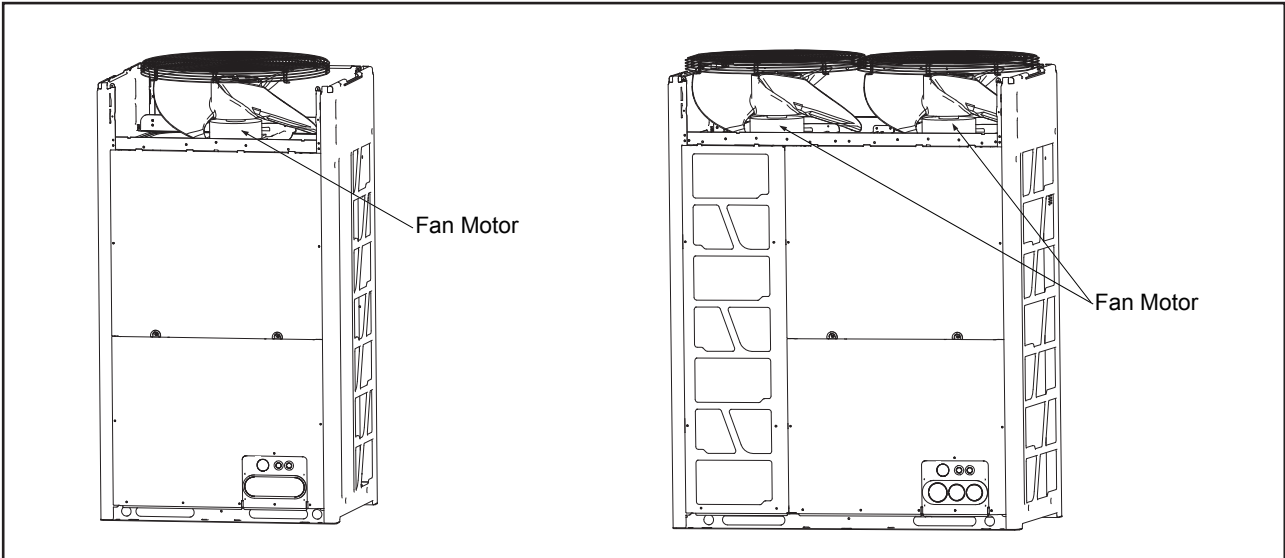

- (2) Remove the closing nut and the flwasher fixing in the propeller fan onto the motor shaft with an box wrench.
- (3) Remove the propeller fan from the motor shaft (Lift the propeller fan up). When attaching the propeller fan to the motor shaft, make the D-Cut at the boss portion connected to the D-Cut of the fan motor shaft.

NOTE:

DO NOT apply an excessive force to the shroud (plastic part) . Otherwise, deformation and breakage may occur.

Tool	Adjustable Wrench, Spanner, Puller, Phillips Screwdriver, Nippers, Box Wrench
------	---

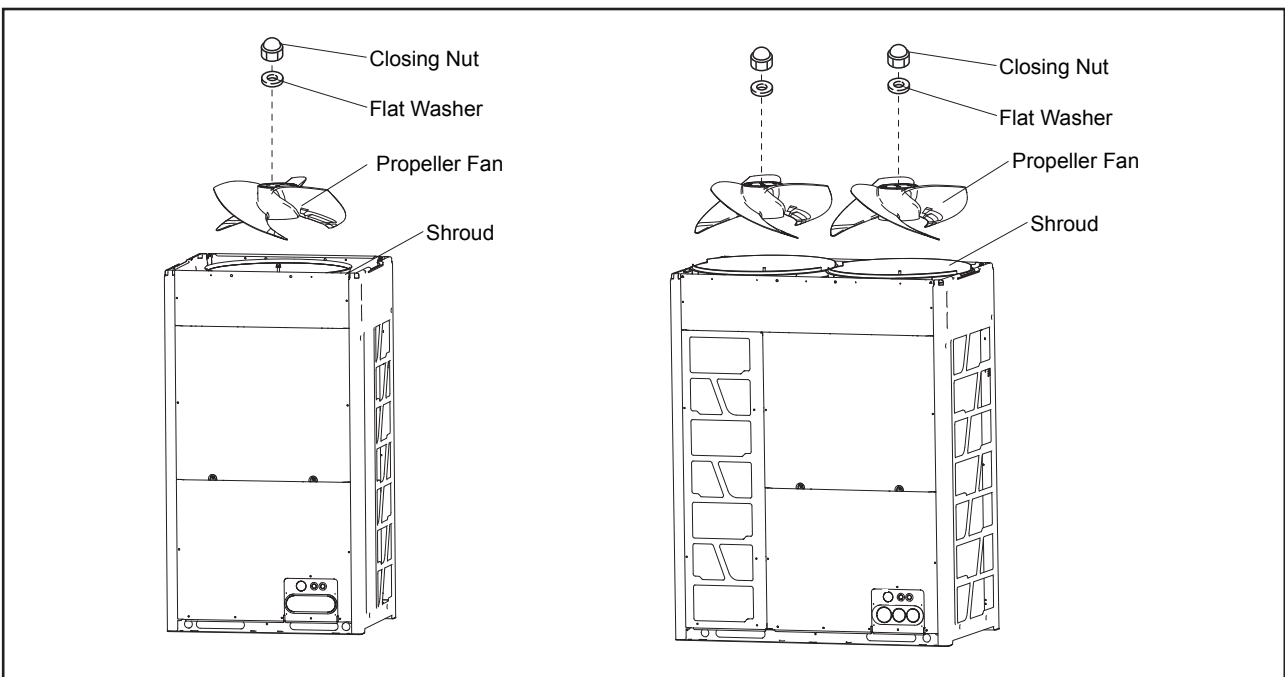

! WARNING

TURN OFF all power source switches.

(4) Removing Wire

- (a) Remove the service cover and the electrical box cover according to the item 2.1 "Removing Front Service Cover" and the item 2.5 "Removing Electrical Box Cover".
- (b) Disconnect the wire connector for the fan motor in the electrical box.
- (c) Unfix the lead wire connecting the electrical box and the fan motor.
- (d) Remove M6 bolts fixing in the fan motor, and remove the fan motor.
Single Fan: 4 bolts
Double Fan: 8 bolts

(5) Set up the wire in the reverse procedure.

NOTE:

- The cord outlet end should be downward-facing when mounting the fan motor.
(Make a wire trap.)
- Fix the motor wire to the motor clamp with a plastic tie to avoid contact with the propeller fan.
- When mounting the propeller fan on the motor shaft, make the D-Cut at the boss portion (⊖ mark part) connected to the D-Cut of the fan motor shaft.
Firmly fix the propeller fan with 30 N.m torque after the head of the fan shaft comes up.

Torque for Mounting Propeller Fan
30 N.m

- Connect the wire connector for the fan motor with the wire connector in the electrical box.

(6) After mounting the fan motor, check from above that gap between the propeller fan and the upper cover is even. Also check that there is no noise caused by contact between the propeller fan and the upper cover during the propeller fan operation.

Tool	Adjustable Wrench, Spanner, Puller, Phillips Screwdriver, Nippers, Box Wrench
------	--

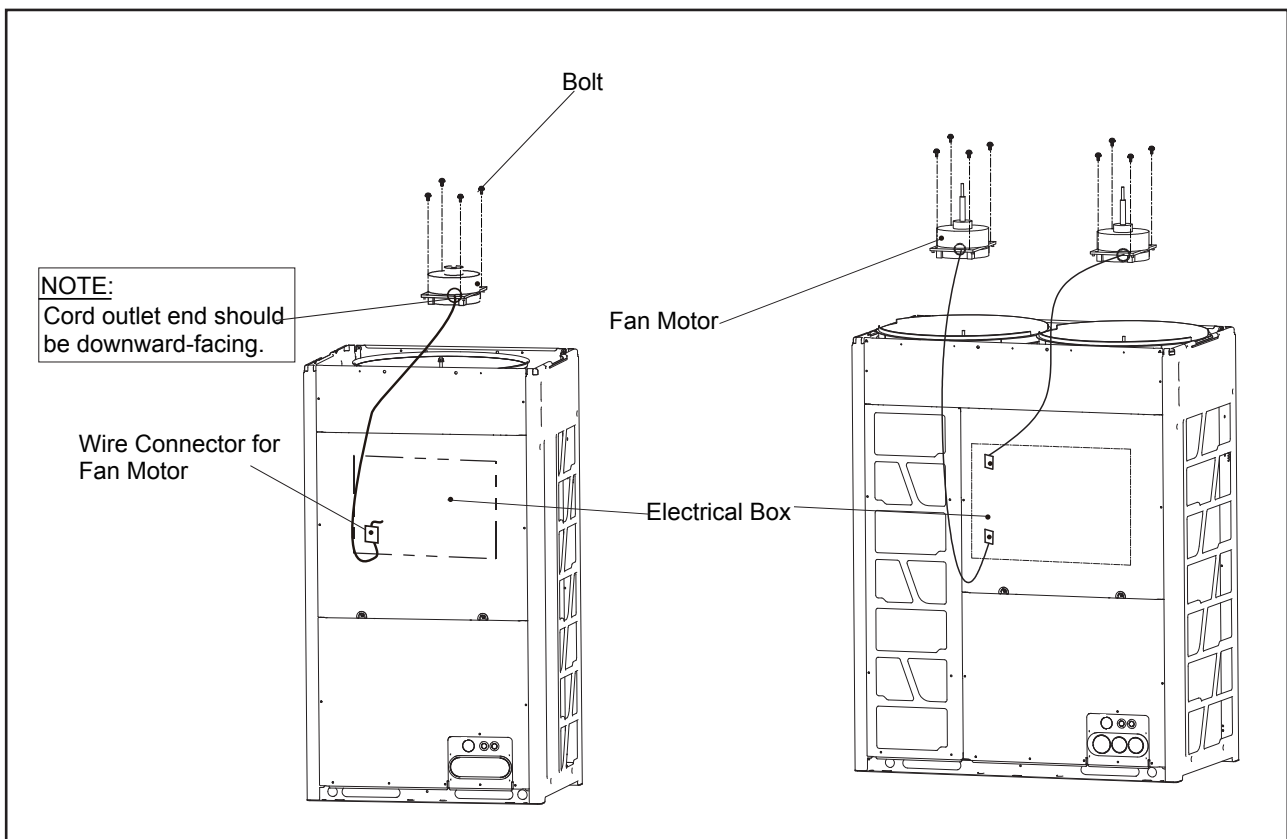

! WARNING

TURN OFF all power source switches.

2.10 Removing Compressor

- (1) Remove the front service cover according to the item 2.1 "Removing Front Service Cover".
- (2) Remove the electrical box cover according to the item 2.5 "Removing Electrical Box Cover".
- (3) Remove the electrical box according to the item 2.6 "Removing Electrical Box".
- (4) Remove the e-box stay according to the item 2.7 "Removing E-Box Stay".
In the case that the outdoor unit is installed closely to the wall, remove the refrigerant piping and move the outdoor unit away from the wall.
- (5) Remove the sound proof cover.
- (6) Remove the Td thermistor on the top of the compressor.

Tool	Screw-driver & Diagonal Pliers
------	--------------------------------

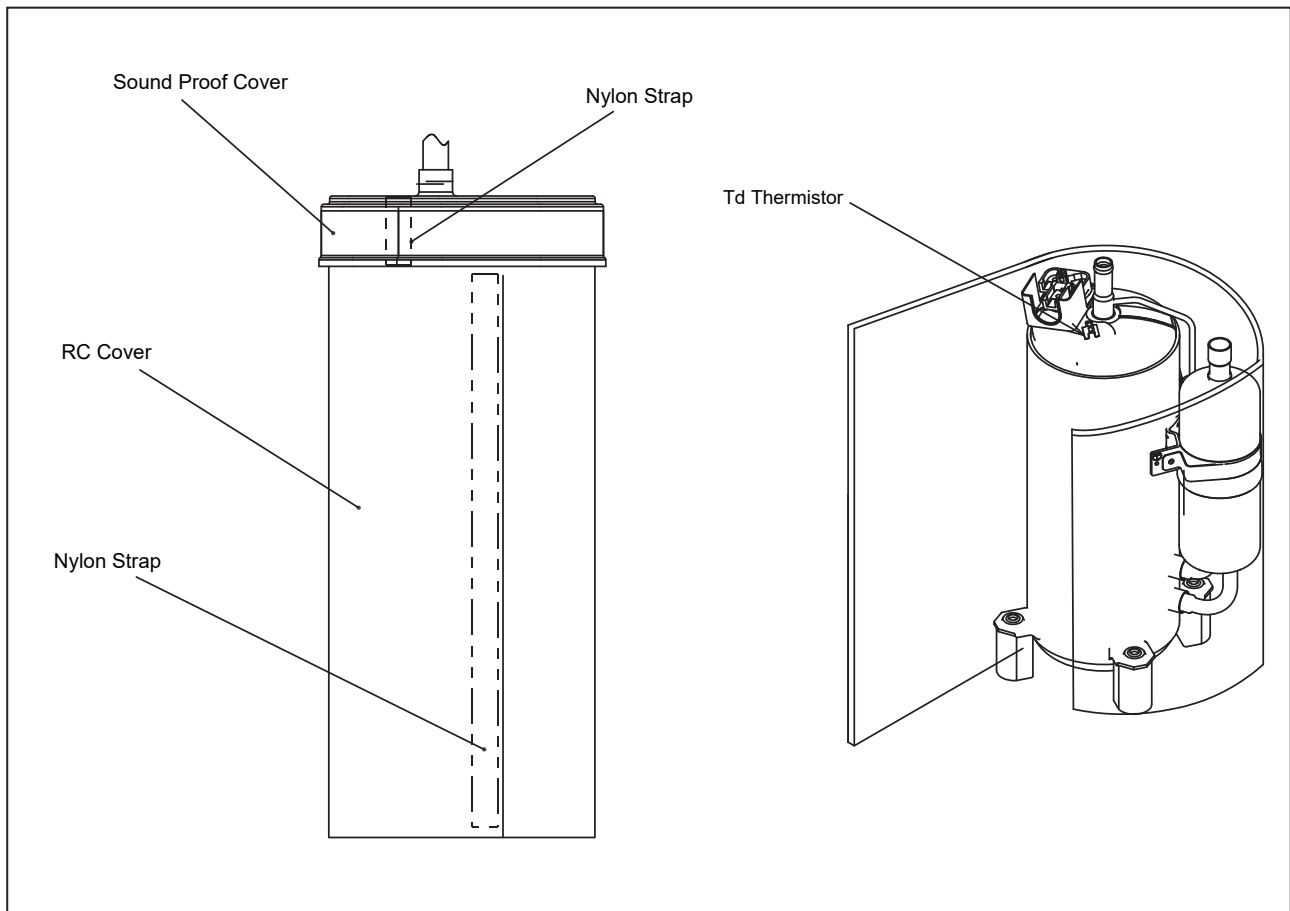

! WARNING

TURN OFF all power source switches.

(7) Release the Nylon strap for the RC cover to remove.

NOTE:

- When removing the RC cover, take special care not to deform the piping around the cover. The brazing parts may be damaged due to pipe deformation.
- When removing the RC cover, take special care not to be injured with the sheet metal edges or the heat exchanger fins.
- The aluminium sheet is conductive. If the aluminium sheet is damaged, it may lead to failure due to electrical wiring contact. To avoid such a failure, check the RC cover condition before fixing the cover.

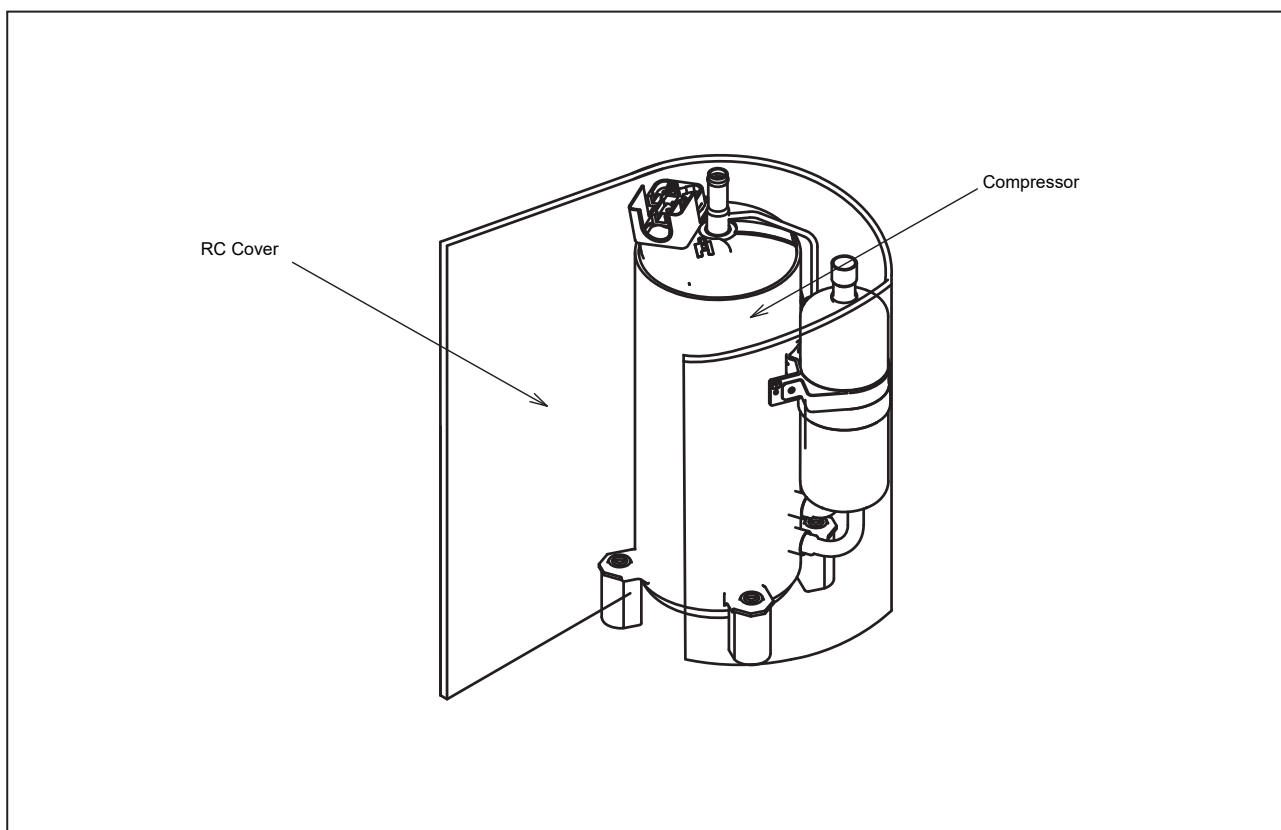

! WARNING

TURN OFF all power source switches.

(8) Remove the terminal box cover for the compressor and disconnect the wiring to the compressor terminals. Then, check the terminal Nos. and the mark band Nos.. Match the terminal Nos. with the mark band Nos. when rewiring the compressor. If they are incorrectly connected, the compressor may be damaged due to reverse rotation.

NOTE:

- When replacing the compressor, check for the ring terminal condition. If there is something wrong with any of the ring terminals, replace it with a new one.
- Fix the lead wire firmly with plastic ties
- Re-tighten the compressor screws after the replacement.

Tool	Phillips Screwdriver, Spanner
------	-------------------------------

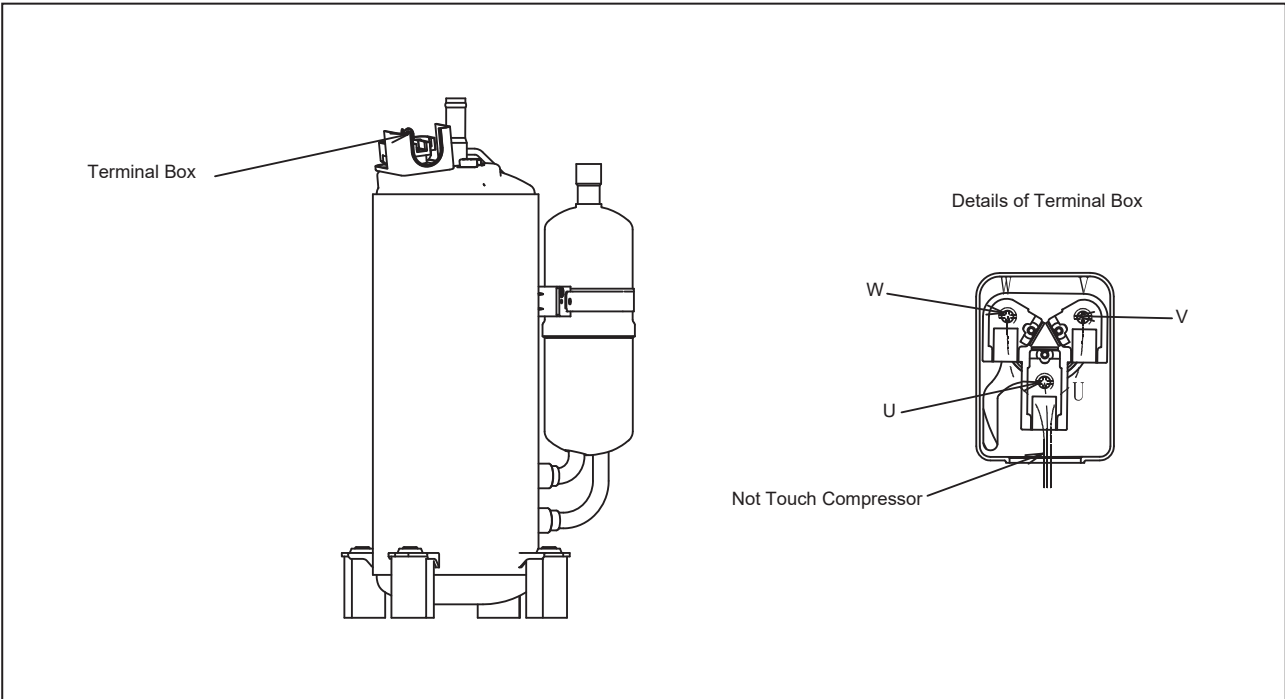

(9) Release the spring for the crankcase heater to remove it.

Tool	Long-nose Pliers
------	------------------

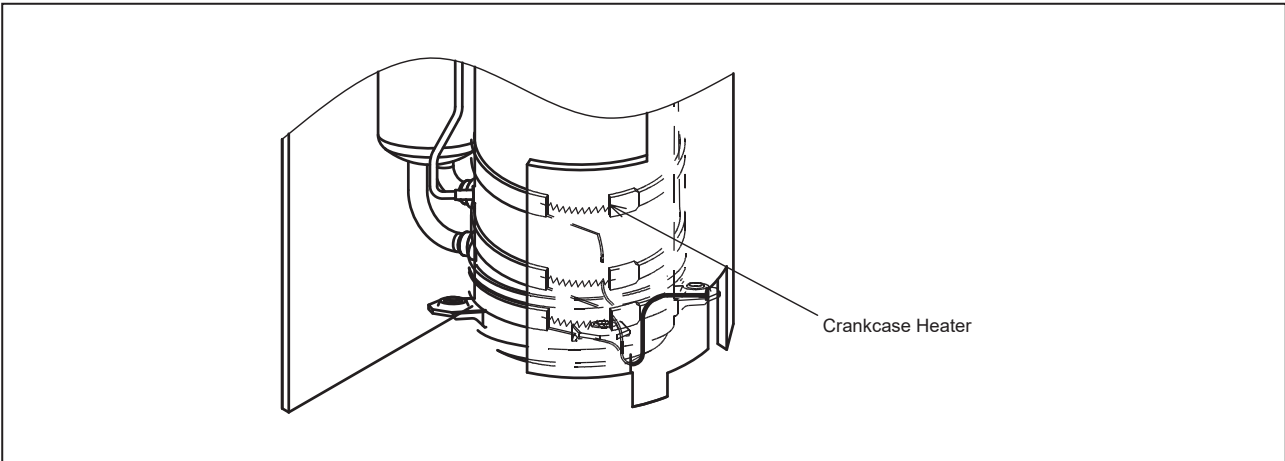

! WARNING

TURN OFF all power source switches.

(10) Disconnect the discharge and suction pipes from the compressor.

Check that the pressure in the piping is equal to the atmospheric pressure. Then, cut the pipes at the closer position to the compressor from each brazing part. After cutting the pipes, remove the pipes from the brazing parts of the compressor.

NOTE:

- All the pipes are connected by brazing. When applying the burner to the pipe connections, the oil adhered inside the pipes may burn. So clear flammable materials around the compressor before the work.
- Burner work under applying gas pressure is very dangerous. Make sure to cut the pipes first before burner work.
- When disconnecting the suction pipe, use an oil pan and such in case the remaining refrigerant oil spills.
- DO NOT throw out the oil collected with the oil pan and such. The oil quantity must be measured afterward.

Tool	Pincher, Burner, Oil Pan, Burner (Welder), Pipe Cutter
------	--

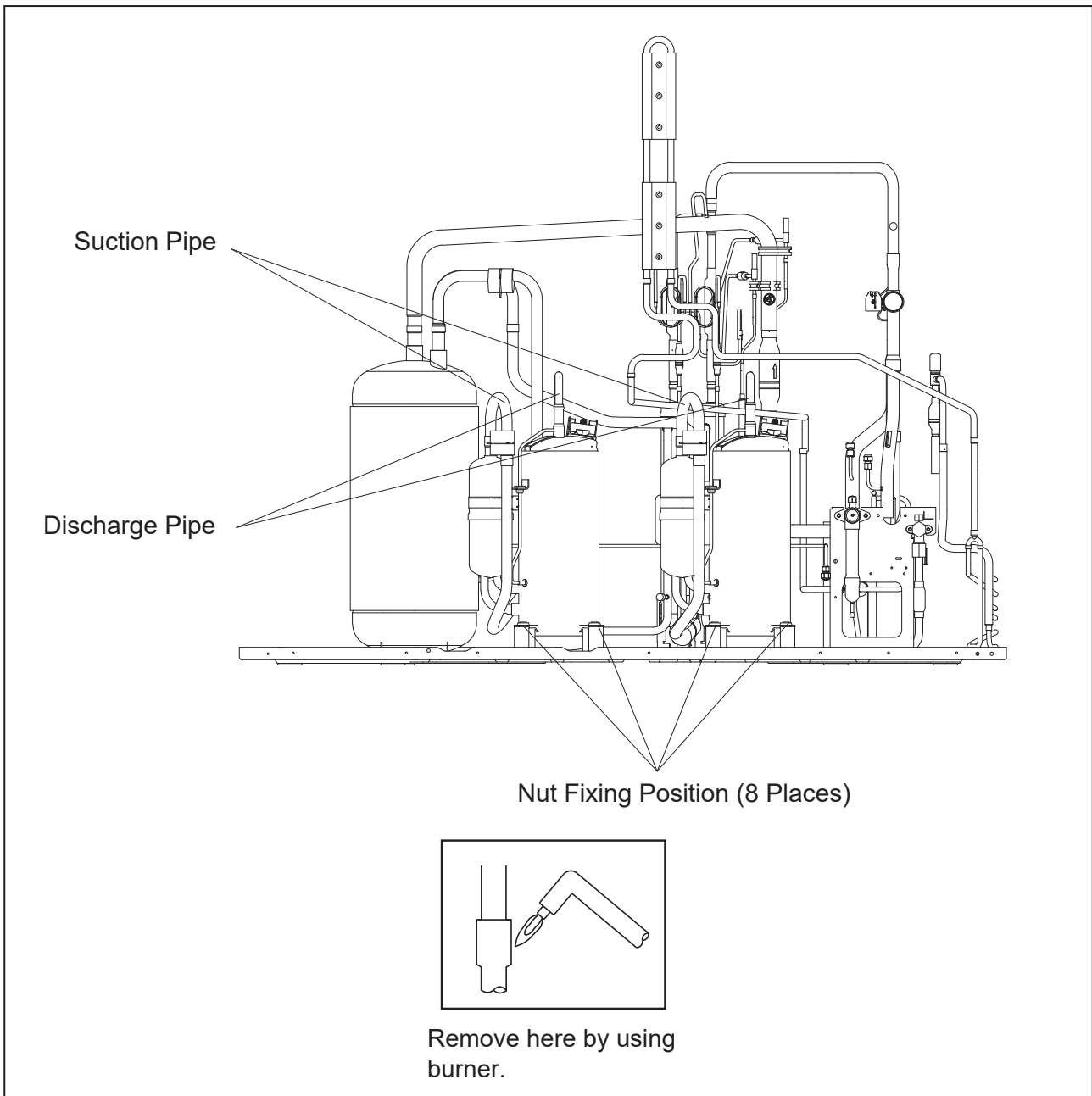

! WARNING

TURN OFF all power source switches.

- (11) Remove four (4) nuts fixing the compressor and remove the compressor.

Tool	Adjustable Wrench, Box Wrench, Phillips Screwdriver, Spanner
------	---

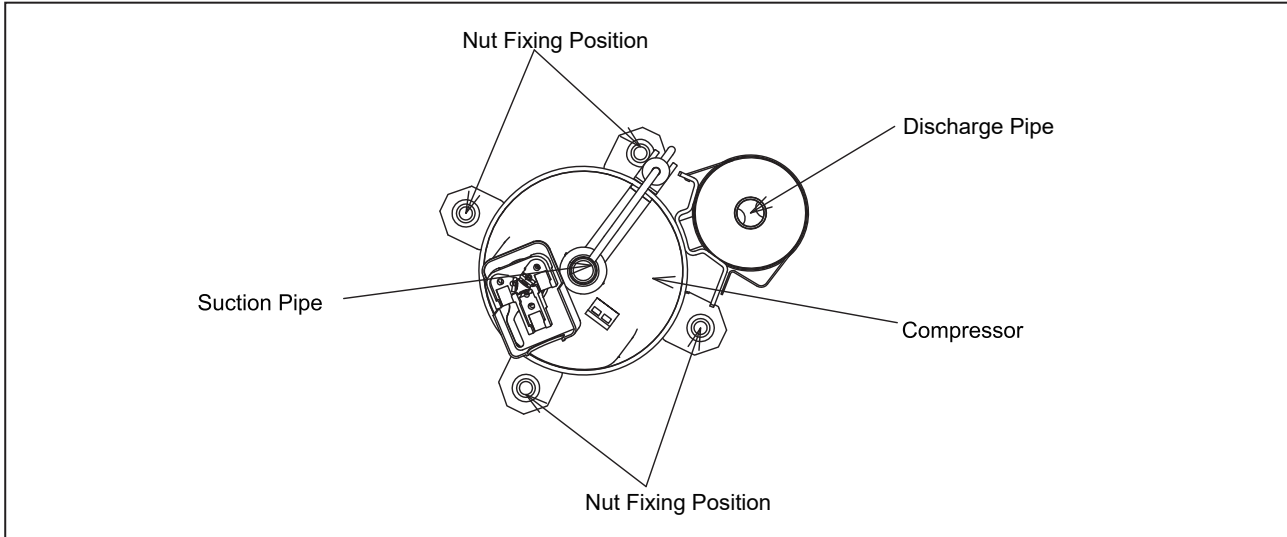
**NOTE:**

- When removing the compressor, take special care not to contact with the surrounding pipes. If contacted, the pipes may be deformed.
- Take special care not to be injured with the sheet metal edges while working.
- To prevent water and foreign particles from entering the refrigerant cycle, mount the new compressor immediately after removing the old one.
- When removing the compressor, remove the electrical box located above the compressor to make the work easier. 10 mm box wrench is required to remove the nuts fixing the compressor .

! WARNING

TURN OFF all power source switches.

(12) Withdraw the remaining refrigerant oil in the compressor from the discharge pipe, and measure the oil quantity.

NOTE:

- Additional refrigerant oil charge is required if:
remaining refrigerant oil quantity in the old compressor > pre-charged refrigerant oil in the new compressor
- No additional refrigerant oil charge is required if:
remaining refrigerant oil quantity in the old compressor < pre-charged refrigerant oil in the new compressor
- The recharged quantity of the refrigerant oil to the cycle is calculated as follows:
(Remaining quantity in the old compressor + Collected quantity in the item 2.10 (10) + 200 cc*) -
(Initial charged quantity in the compressor for each model)

Compressor	Initial Charged Refrigerant Oil
ATH550SKRC8FQP	1350ml
ATE650SKTQ9JKP	2000ml
ATE848SKTQ9JKP	2000ml

* 200cc : This value is not considered to be removed from the chamber.

Tool	Oil Pan, Measure Cup
------	----------------------

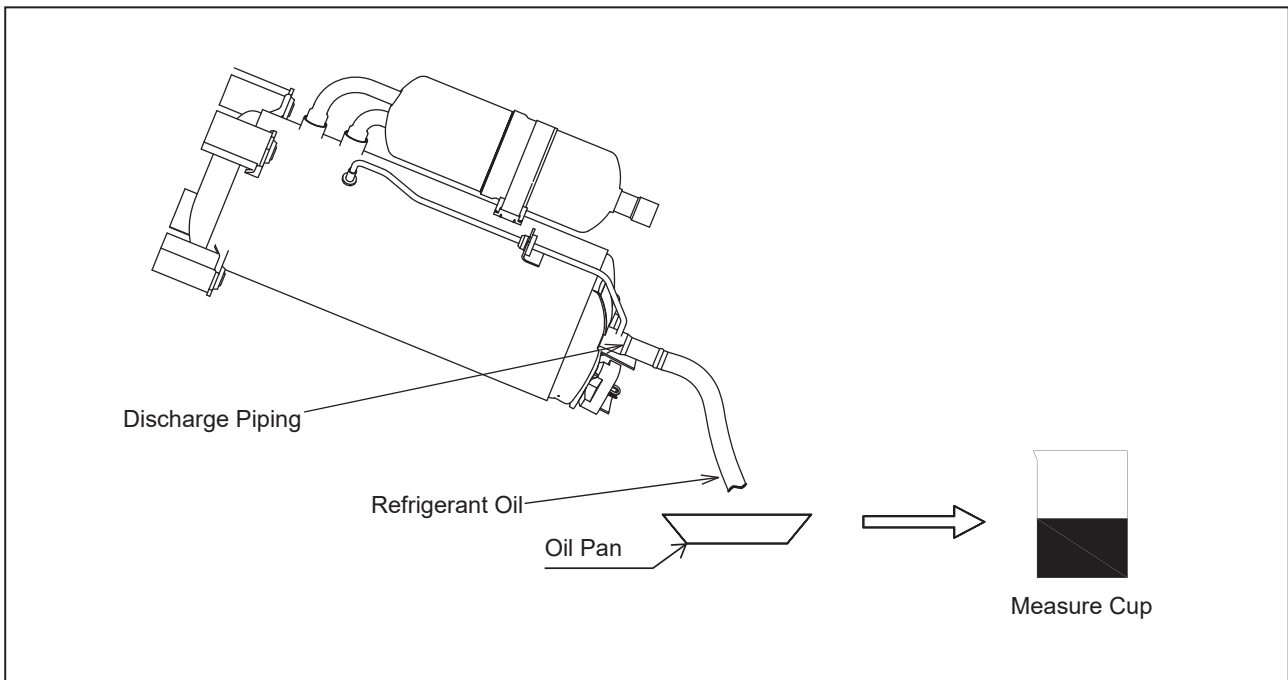

! WARNING

TURN OFF all power source switches.

(13) Mount the new compressor.

Attaching the nuts first and then perform brazing according to the following order:

- (a) Discharge Pipe
- (b) Suction Pipe

NOTE:

- When mounting the new compressor on the base, take special care not to contact the piping. If contacted, piping may be deformed.
- The new compressor should be mounted with the cap, and remove the cap just before starting the brazing work.
- Connect the charging hose with the check joint at the low pressure side to release pressure.
- When brazing the suction pipe, make sure that the connecting part is firmly inserted into the compressor and that the piping root is cooled, in order to prevent the brazing material from entering the compressor.

Tool	Burner, Wet Cloth, Pliers
------	---------------------------

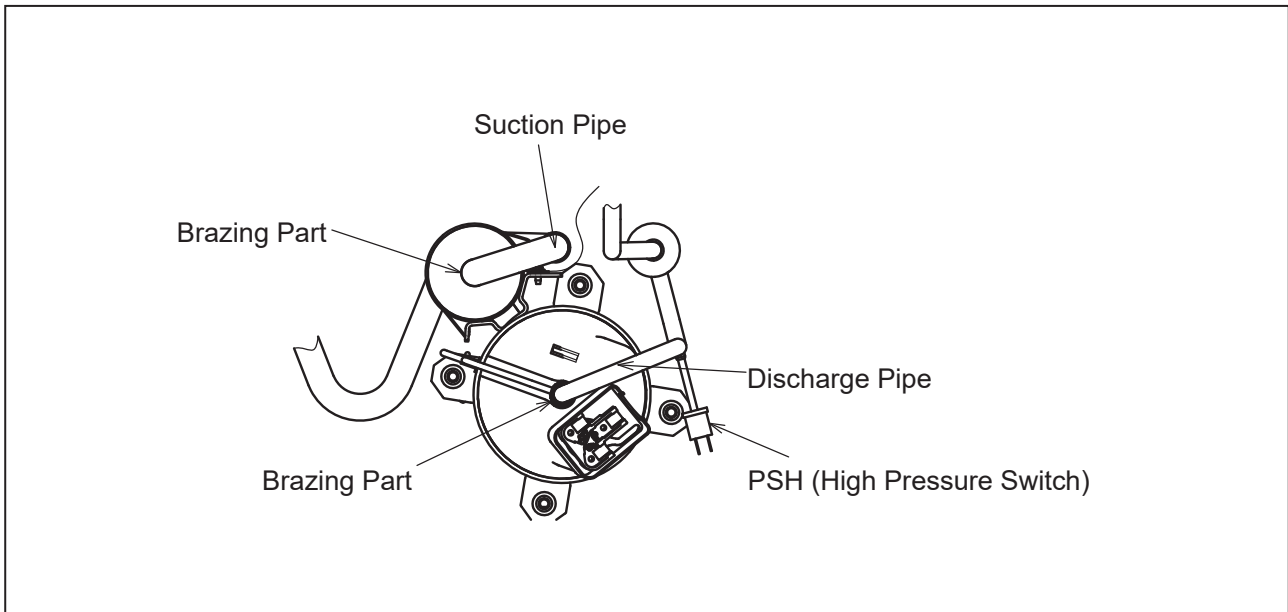

! WARNING

TURN OFF all power source switches.

- (14) Wind the crankcase heater around the compressor.
- (15) Attach the RC cover to the compressor.
- (16) Reconnect all wires.
 - (a) The crankcase heater lead wire, the power line and compressor earth wire pass through the internal noise enclosure, without contacting the piping.
 - (b) Draw the lead wire for high pressure switch (PSH) and attach the Td thermistor. Pull out the wire from the dent part at the top of the RC cover.

NOTE:

- If the power line or the crankcase heater lead wire contacts the high temperature part such as the discharge pipe or compressor chamber, the wire may be cut or catch fire. Protect the wire from overheating and protect the edge with the RC cover.
- Check that the high pressure switch (PSH) does not contact the RC cover aluminium sheet.

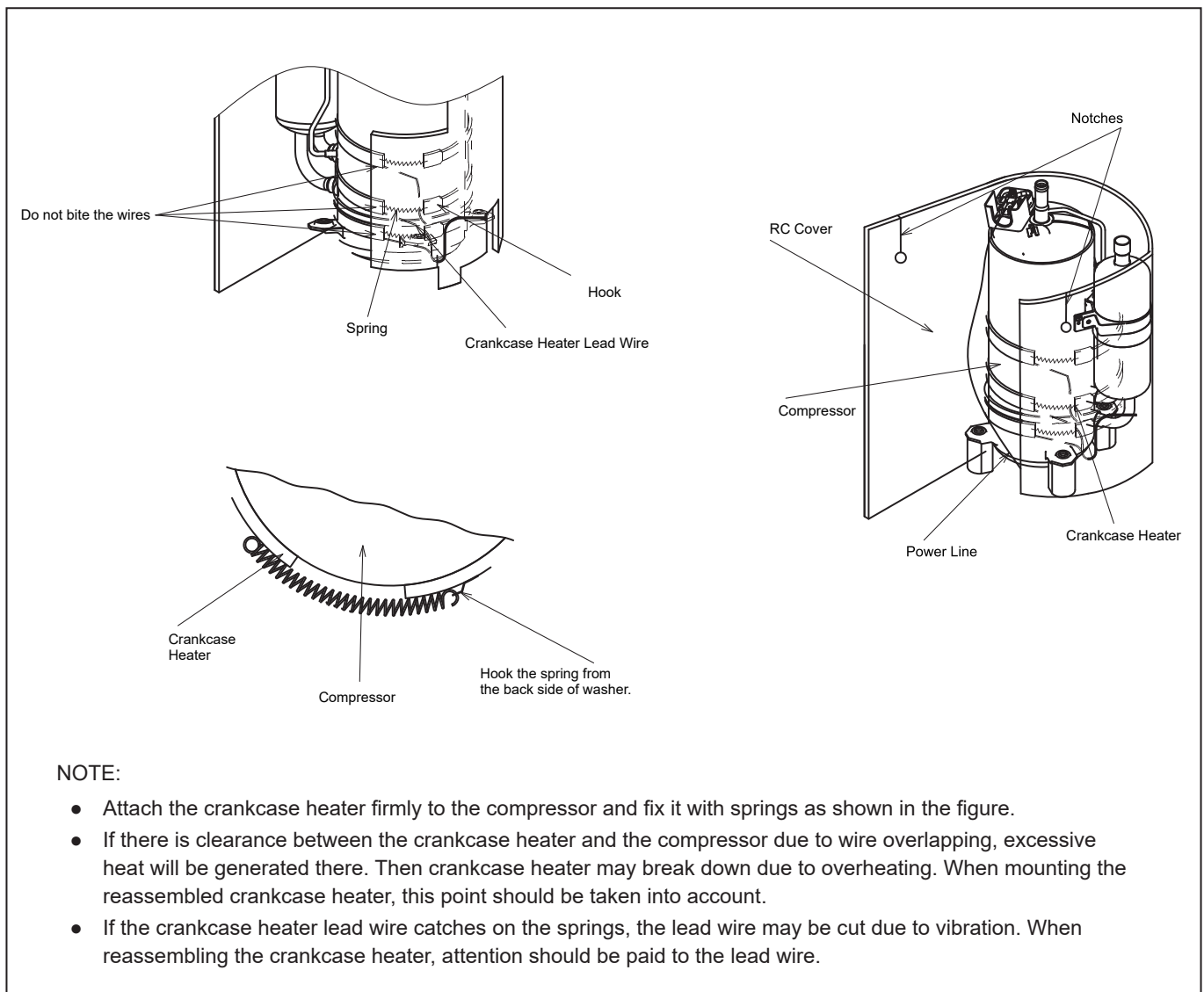

NOTE:

- Attach the crankcase heater firmly to the compressor and fix it with springs as shown in the figure.
- If there is clearance between the crankcase heater and the compressor due to wire overlapping, excessive heat will be generated there. Then crankcase heater may break down due to overheating. When mounting the reassembled crankcase heater, this point should be taken into account.
- If the crankcase heater lead wire catches on the springs, the lead wire may be cut due to vibration. When reassembling the crankcase heater, attention should be paid to the lead wire.

! WARNING

TURN OFF all power source switches.

- (c) Fix the cover firmly with wire clamp to prevent water from entering from the clearance between the RC cover and the sound proof cover.

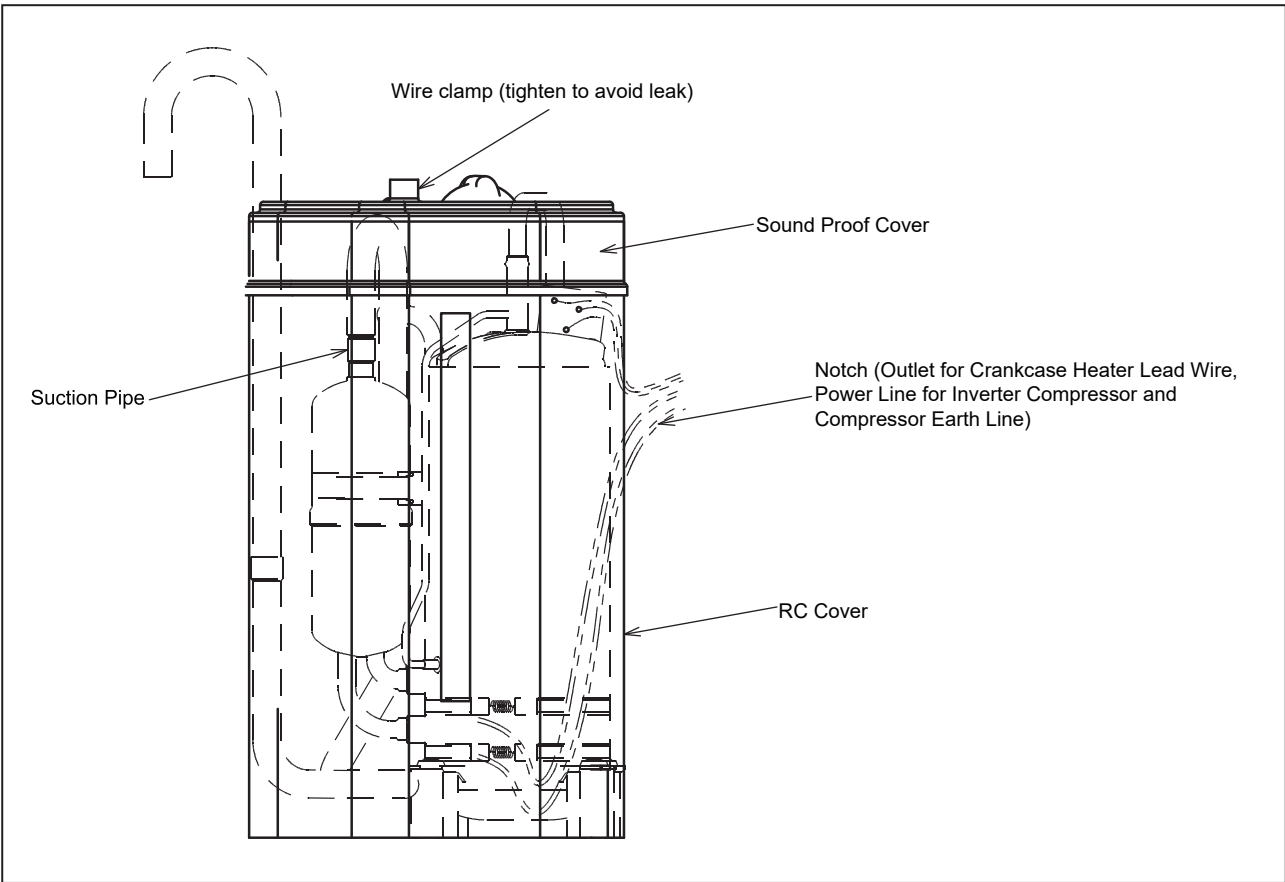

! WARNING

TURN OFF all power source switches.

(17) Perform the final check for wiring conditions referring to the figure below.

NOTE:

Check that all wires do not contact the compressor, piping and plate edges. If any of the wires contacts with them, wire breakage or fire may occur.

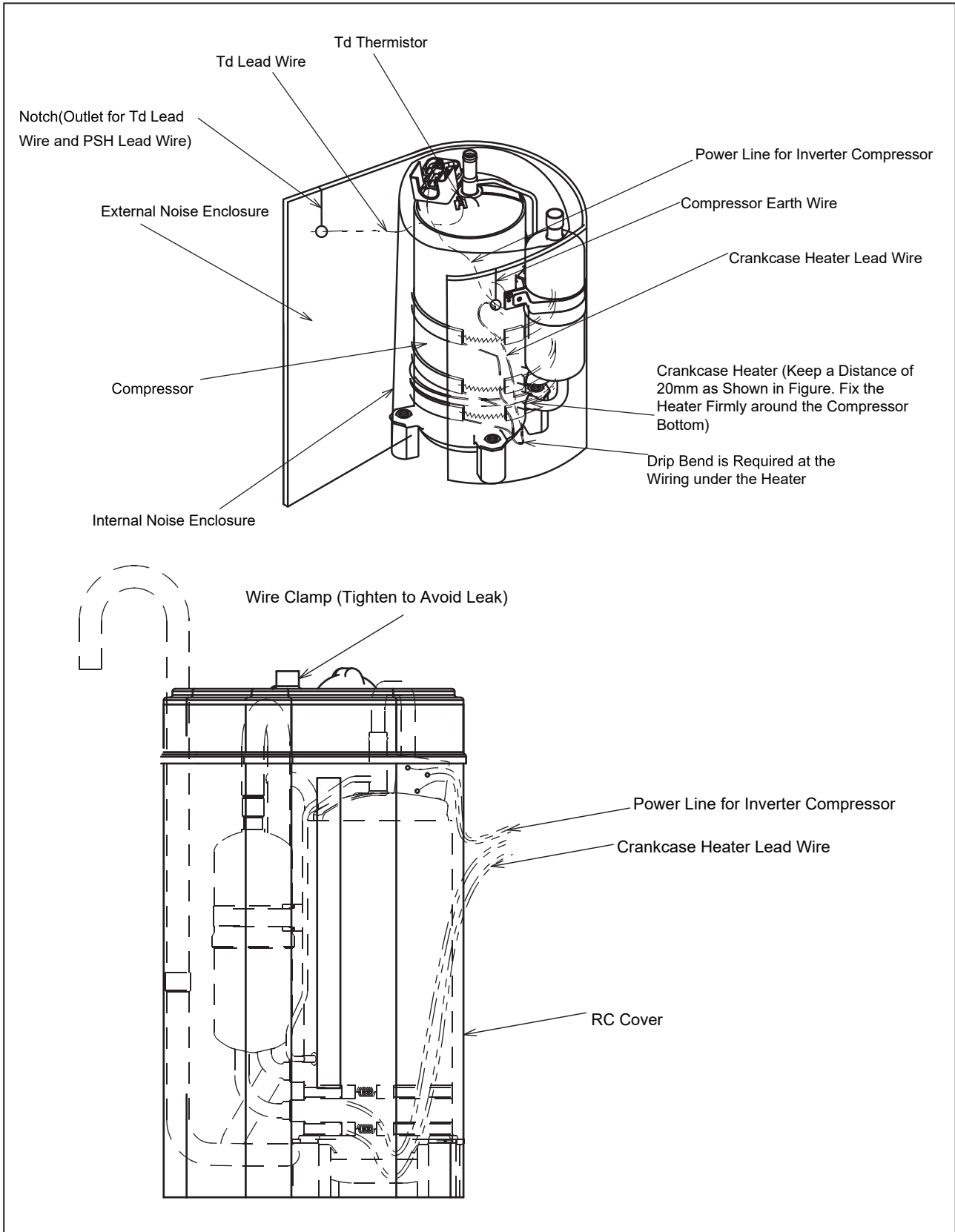

! WARNING

TURN OFF all power source switches.

2.11 Replacing Refrigerant Oil

2.11.1 Replacing Refrigerant Oil (No Clogging in Return Oil Circuit)

- (1) Remove the front service cover according to the item 2.1 "Removing Front Service Cover".
- (2) Close (B) liquid stop valve and (A) gas stop valve.
- (3) Collect the refrigerant in the outdoor unit from (D) gas pipe check joint and (E) high pressure check joint. Check that the pressure will not increase at this time.

NOTE:

If the pressure increases, collect all the refrigerant in the refrigerant cycle.

- (4) Connect a charge hose (for R410A) to (C) check joint for collecting refrigerant oil.
- (5) Charge nitrogen (0.15MPa) from (D) gas pipe check joint and collect the refrigerant oil in the accumulator, applying pressure. (approx. 20 minutes)

NOTE:

Ensure that the pressure on (E) high pressure check joint is NOT abnormal when nitrogen is charged.

- (6) Stop charging nitrogen after the refrigerant oil has been completely collected.
Perform vacuuming from (D) gas pipe check joint and add the same quantity of oil as the collected refrigerant oil.

NOTE:

When the collected refrigerant oil is 3L or less, clogging may exist in the return oil circuit. In that case, replace the return oil circuit according to the item 2.11.2 "Clogging in Return Oil Circuit".

- (7) When the procedures have been completed, perform vacuuming again from (D) gas pipe check joint and recharge the refrigerant. After recharging, open the stop valves.

NOTES:

- Use a clean charging hose.
- Charge the refrigerant oil in a short time (within approx. 20 minutes).
Use a container with a small opening so that the refrigerant oil does not absorb the moisture in the atmosphere.

Tool	Adjustable Wrench or Spanner
------	------------------------------

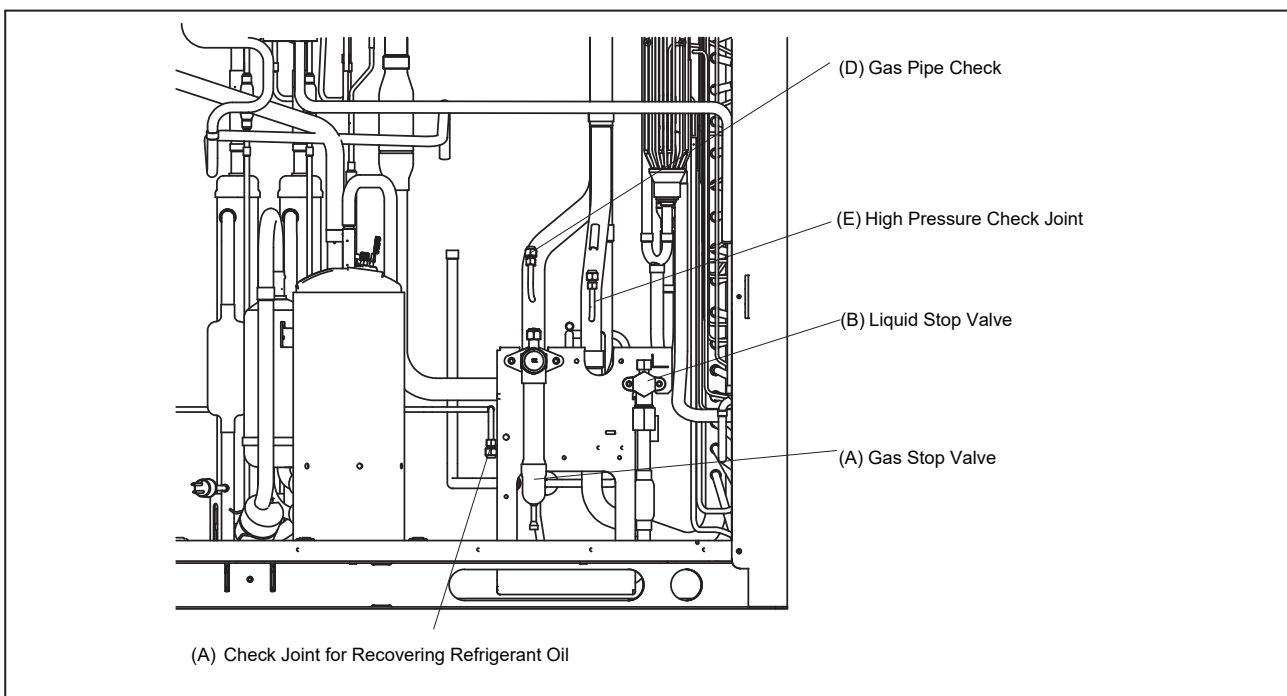

! WARNING

TURN OFF all power source switches.

2.11.2 Replacing Refrigerant Oil (Clogging in Return Oil Circuit) and Replacing Return Oil Circuit

- (1) Remove the front service cover according to the item 2.1 "Removing Front Service Cover".
- (2) Remove the electrical box, wirings and E-box stay according to the item 2.6 "Removing Electrical Box"
- (3) Close (B) liquid stop valve and (A) gas stop valve.
- (4) Collect the refrigerant in the outdoor unit from (D) gas pipe check joint and (E) high pressure check joint. Check that the pressure will not increase at this time.

NOTE:

If the pressure increases, collect all the refrigerant in the refrigerant cycle.

Tool	Adjustable Wrench or Spanner
------	------------------------------

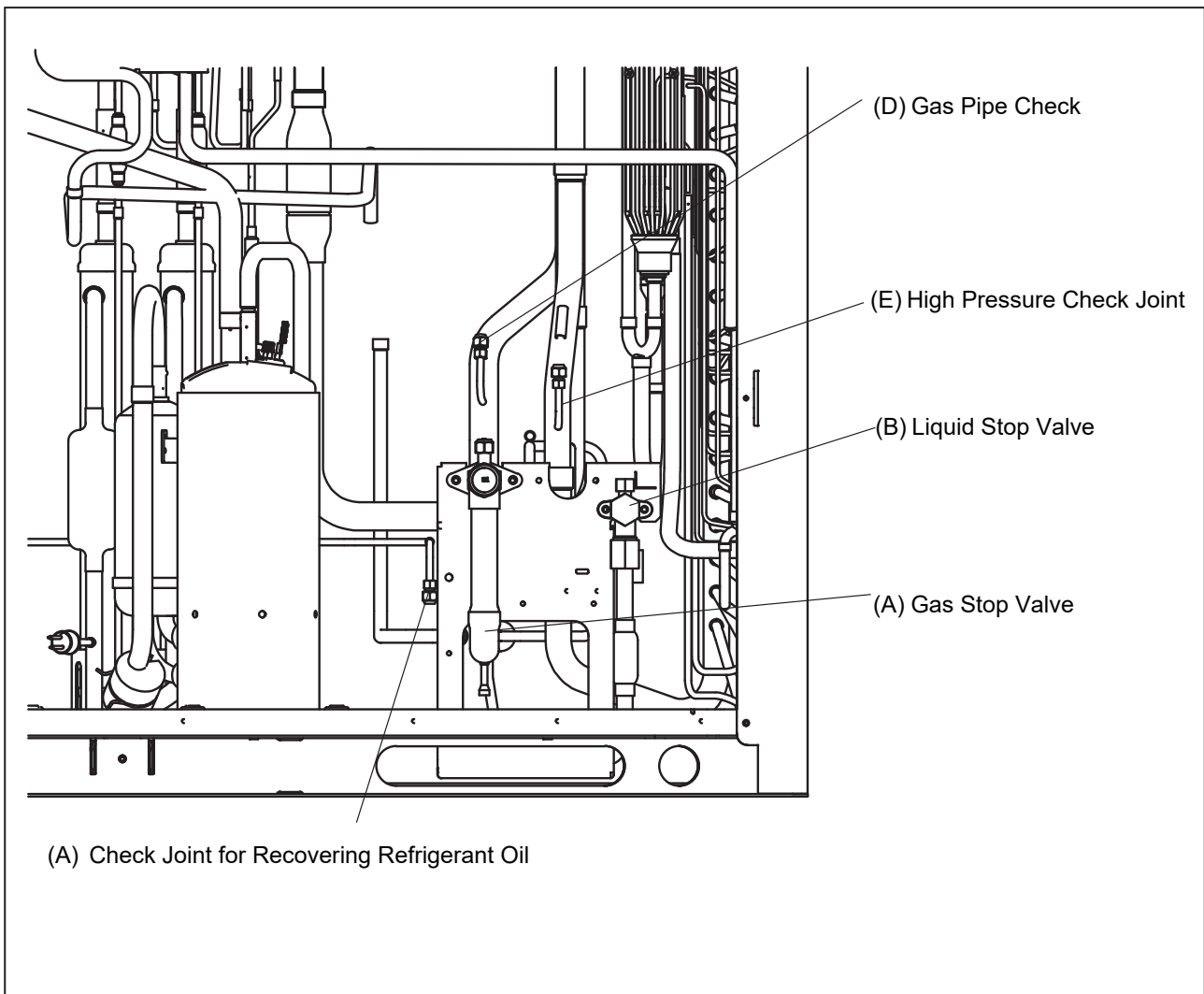

! WARNING

TURN OFF all power source switches. Keep the pressure of the unit below zero before the brazing work.

- (5) Brazing (G) return oil circuit from (J) oil separator outlet port and (F) suction pipe brazing port at the point indicated in the figure. Remove (G) return oil circuit from the unit. Then seal (F) suction pipe brazing port with 3M tape. Make sure the high pressure gas can not leak from here.

Tool	3M Tape Burner
------	----------------

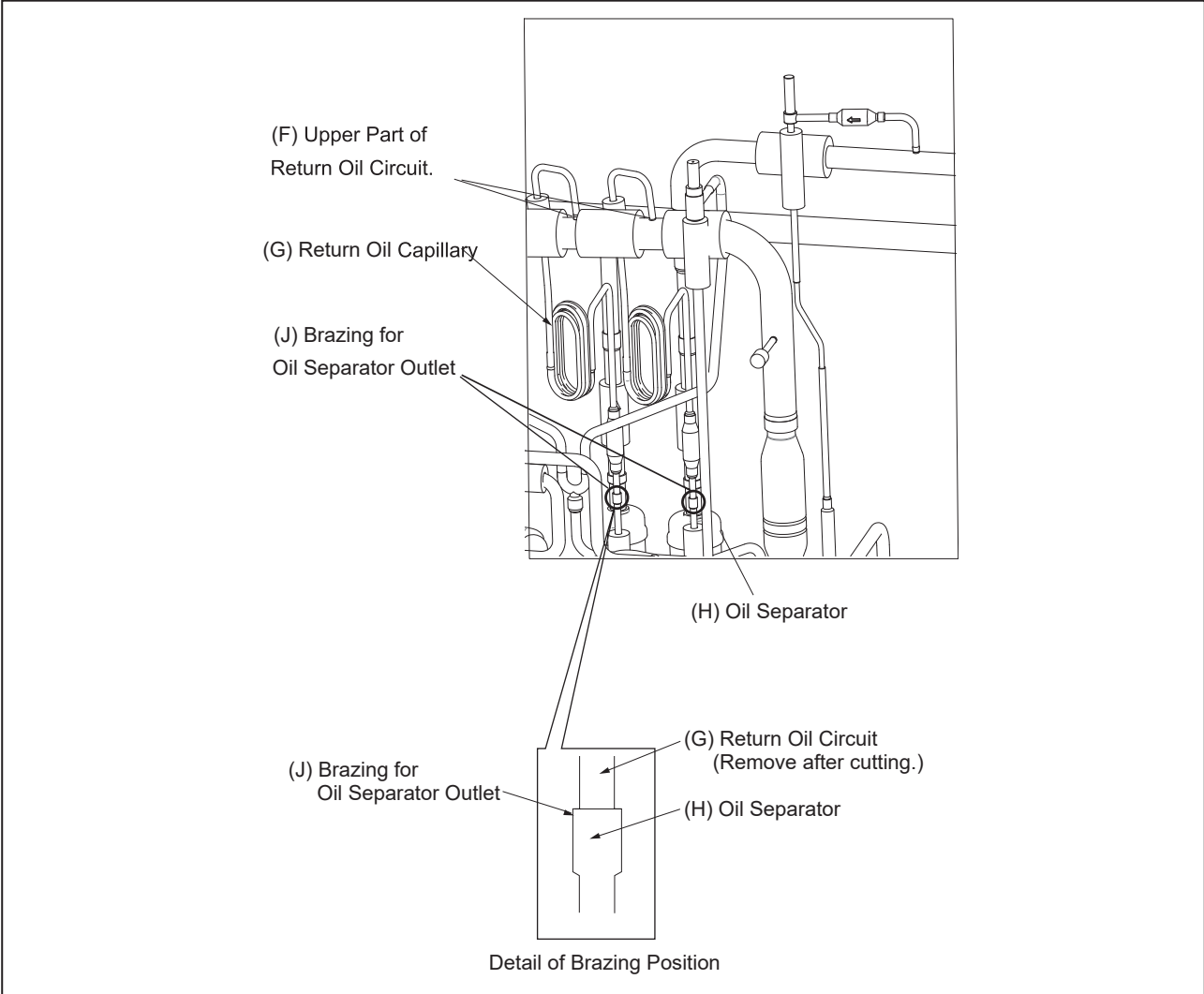

 **WARNING**

TURN OFF all power source switches.

- (6) Connect a charging hose to (J) brazing part of oil separator outlet port. Then, charge nitrogen (0.15MPa) from (D) gas pipe check joint, and collect refrigerant oil in (H) Oil Separator.

NOTE:

In the case that the unit has two (2) return oil circuits and two (2) oil separators (Example: dual compressors systems), collect the refrigerant oil at the same time.

- (7) Stop charging nitrogen after the refrigerant oil has completely been collected ,then remove the tape added in step (5) and resolder a new (G) return oil circuit to the system.

Perform vacuuming from (D) gas pipe check joint and add the same quantity of oil as the collected refrigerant oil from (C) check joint for collecting refrigerant oil.

NOTE:

- In the case of replacing the return oil circuit only, the procedures (6) and (7) are not required.
 - In the case that the unit has two (2) return oil circuits, two new (G) return oil circuits are needed.
 - When resolder (G) return oil circuit to the system, make sure the solder joint is fully inserted.
- (8) Connect the return oil pipe for replacement oil. After connecting the pipe. perform the nitrogen pressurization from (D) gas pipe check joint. During the work, check that oil does not spill out from the brazing part.
- (9) When the procedures have been completed, perform vacuuming again from (D) gas pipe check joint and recharge the refrigerant. After recharging, open the stop valves.

NOTES:

- Use a clean charging hose.
- Charge the refrigerant oil in a short time (within approx. 20 minutes).
Use a container with a small opening so that the refrigerant oil will not absorb the moisture in the atmosphere.

! WARNING

TURN OFF all power source switches.

2.12 Removing Coils

The following figures indicate the position of coils

<Coil Position>

- AVWT-76/96/114HKFXE

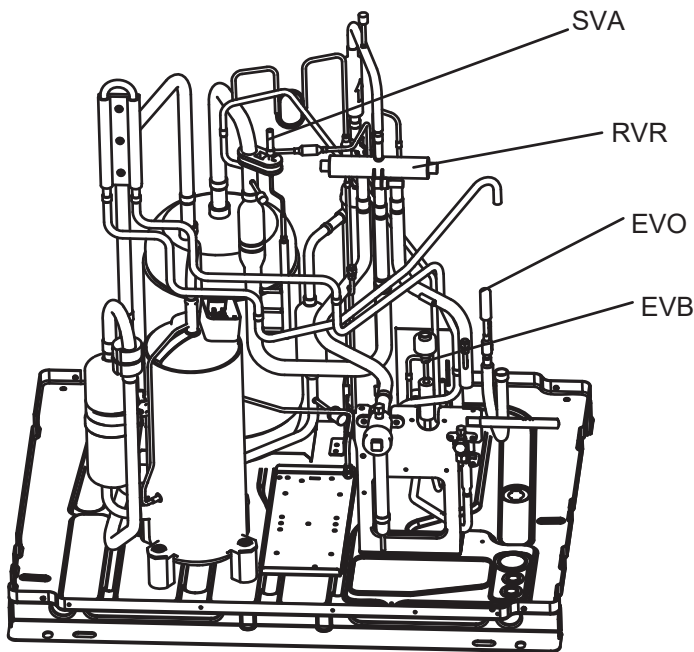

SVA: Solenoid Valve
 RVR: Reversing Valve
 EVB: Expansion Valve
 EVO: Expansion Valve

- AVWT-136-190HKFXE

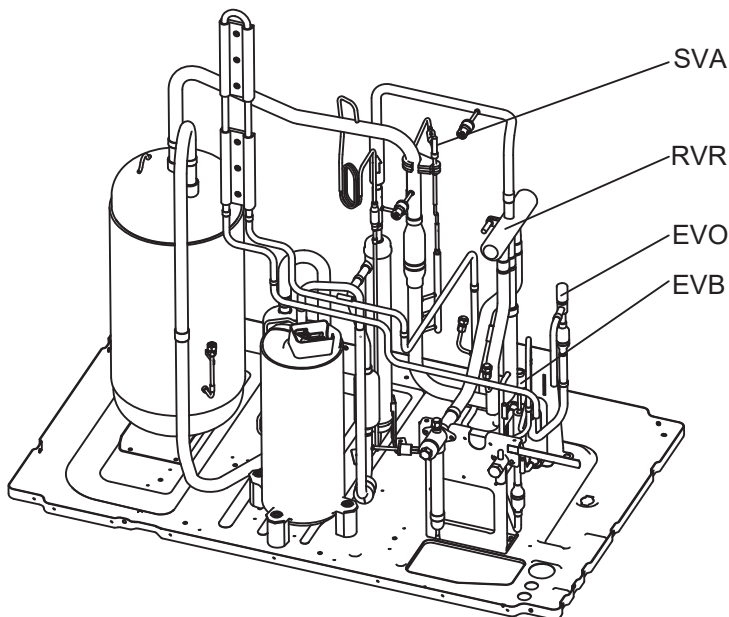

● AVWT-212~272HKFXE

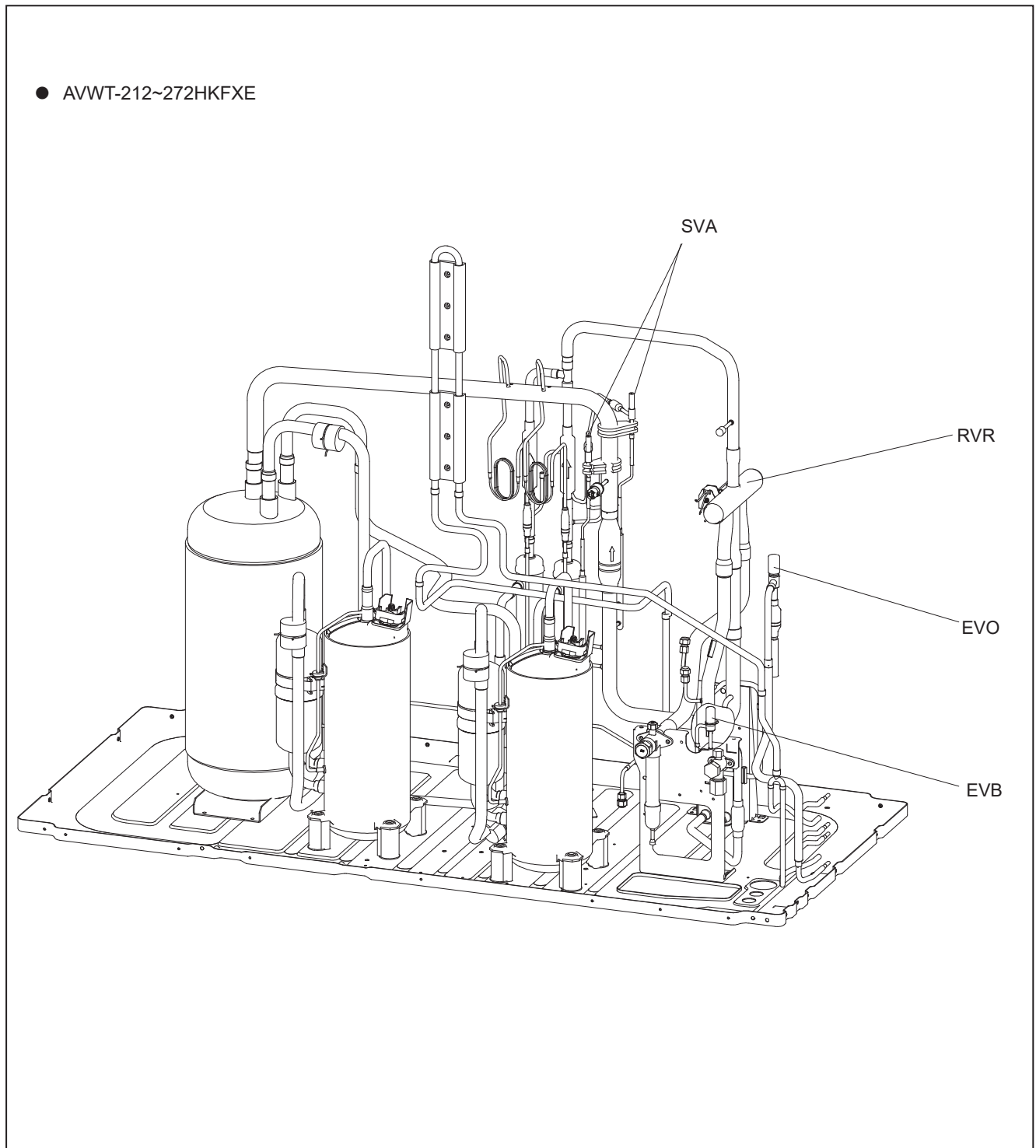

! WARNING

TURN OFF all power source switches.

2.12.1 Removing Expansion Valve Coil (EVB, EVO)

(1) Remove the front service cover according to the item 2.1 "Removing Front Service Cover".

(2) Turn the expansion valve coil in a counterclockwise direction as shown in the figure below .

Remove the expansion valve coil bracket from the expansion valve slot. Then, pull the coil upward.

- Pay attention to the thermistor wiring when removing the expansion valve coils.

NOTE:

Make sure to remove the coil bracket from the coil slot before pulling the coil out. If not, your hand may be hit against the piping as a reaction. Follow the above procedure carefully to avoid any injuries.

Tool	Pliers
------	--------

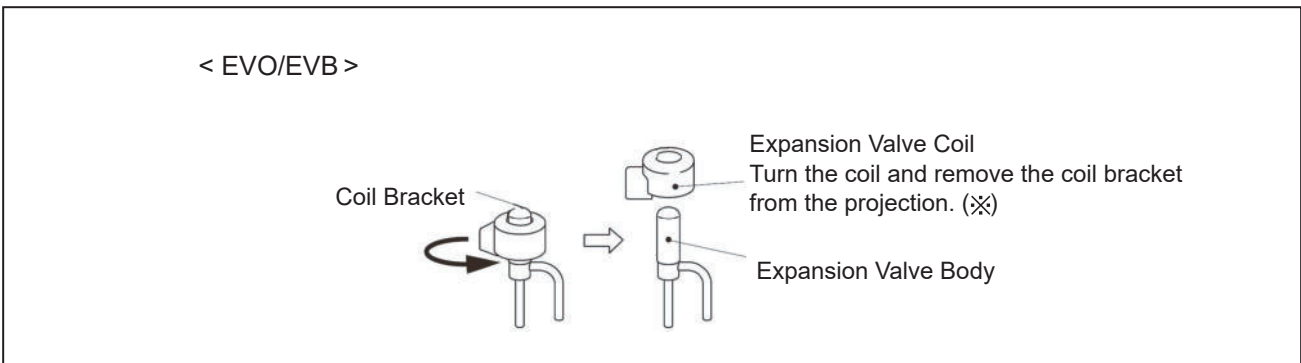

(3) When replacing the expansion valve coils, press the coil into the expansion valve slot turning the coil.

If an excessive force is applied to the coil, the coil bracket may be deformed. As a result, the coil cannot be fixed at the correct position shown in the figure.

- Any slots on the expansion valve inner surface will do.

NOTE:

Do not apply an excessive force to the coil when pressing it into the slot. Otherwise, it may cause damage to the piping.

Tool	Pliers
------	--------

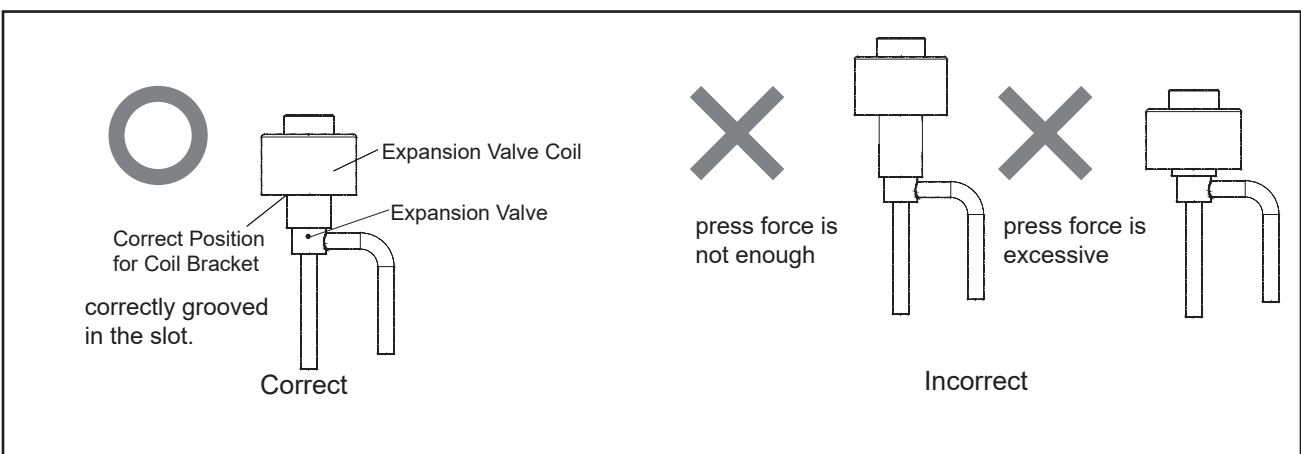

! WARNING

TURN OFF all power source switches.

2.12.2 Removing Solenoid Valve Coil (SVA)

- (1) Remove the front service cover according to the item 2.1 "Removing Front Service Cover".
- (2) Remove one (1) screw fixing the solenoid valve coil with a phillips screwdriver. If the screw is difficult to remove, use a spanner or an adjustable wrench.
- (3) Remove the solenoid valve coil.

Tool	Phillips Screwdriver
------	----------------------

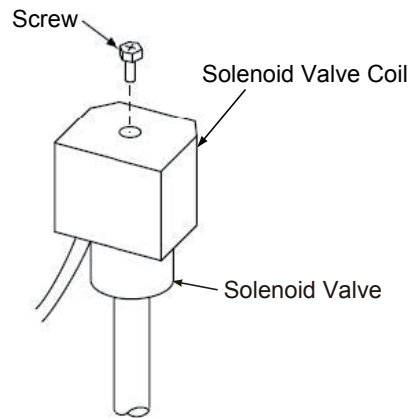

! WARNING

TURN OFF all power source switches.

2.12.3 Removing Solenoid Valve (SVA)

- (1) Remove the front service cover according to the item 2.1 "Removing Front Service Cover".
- (2) <Cooling Only System>
Close the gas stop valve and the liquid stop valve.
- (3) Collect the refrigerant in the outdoor unit from the low pressure check joint and the high pressure check joint. Check that the pressure will not increase at this time.

NOTE:

If the pressure increases, collect all the refrigerant in the refrigerant cycle.

- (4) Remove the solenoid valve coils according to the item 2.12.2 "Removing Solenoid Valve Coil".
- (5) Remove the brazing at the position shown in the figure below. <Example : SVA >

NOTE:

- During brazing work, cover the solenoid valves with wet cloth for cooling.
 - Take special care not to burn the connecting wiring and the piping insulation during brazing work.
- (6) Set the solenoid valves in the reverse procedure.

Tool	Phillips Screwdriver, Charging Hose, Burner, Wet Cloth, Pliers
------	--

- AVWT-76~114HKFXE

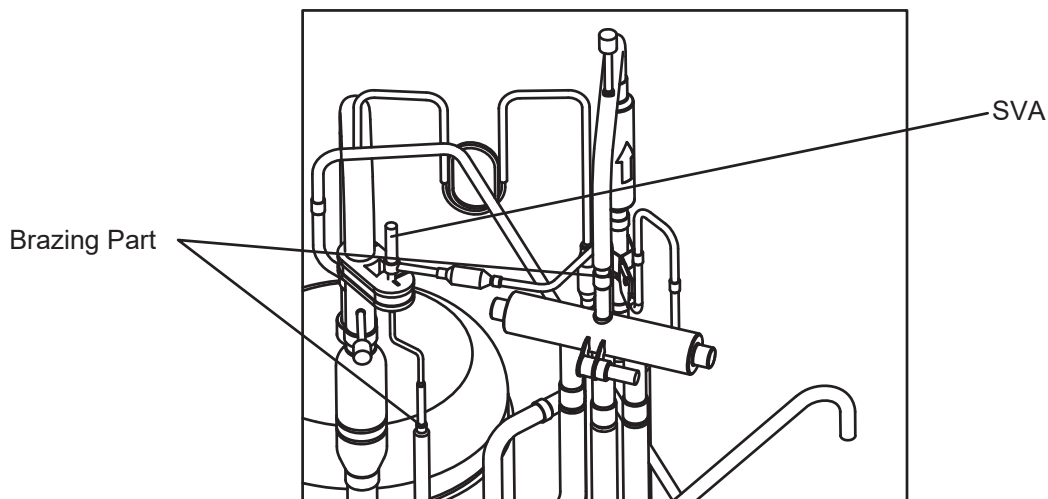

- AVWT-136~170HKFXE

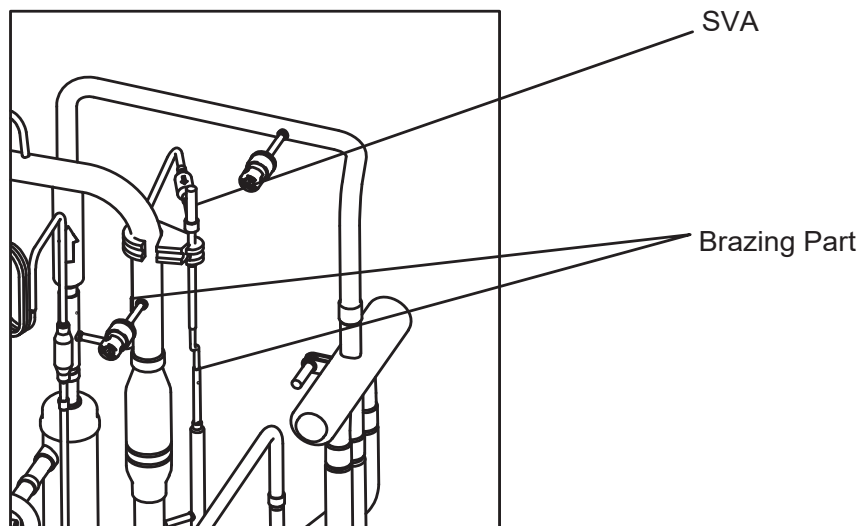

! WARNING

TURN OFF all power source switches.

2.12.4 Removing Reversing Valve Coil (RVR)

- (1) Remove one (1) screw fixing the reversing valve coil with a phillips screwdriver.
If the screw is difficult to remove, use a spanner or an adjustable wrench
- (2) Remove the reversing valve coils.

Tool	Phillips Screwdriver
------	----------------------

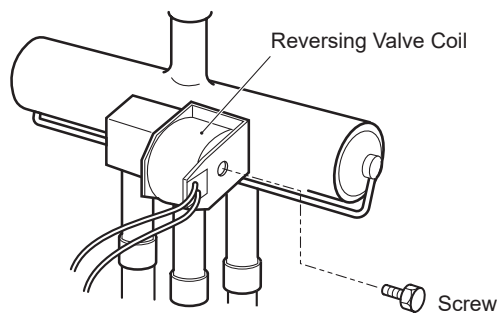

This is the unit front view.

! WARNING

TURN OFF all power source switches. Keep the pressure of the unit below zero before the brazing work.

2.12.5 Removing Reversing Valve

- (1) Remove the front service cover according to the item 2.1 "Removing Front Service Cover".
- (2) Remove the electrical box, wirings and E-box stay according to the item 2.6 "Removing Electrical Box" and the item 2.7 "Removing E-Box Stay."
- (3) Before starting the following work, collect the refrigerant from the refrigerant cycle into a cylinder.
- (4) The reversing valves are fixed at the positions shown in the figure.
- (5) Remove the reversing valve coils according to the item 2.12.4 "Removing Reversing Valve Coil".
- (6) Remove the brazing portion shown in the figures below with the reversing valves and the stop valves covered with wet cloth for cooling.

NOTES:

1. Make sure to remove the brazing portion at the indicated positions in the figures. If not, leakage may occur when reassembling the valves.
 2. Connect the charging hose to the check joint for gas stop valve before removing the brazing.
- (7) Remove the reversing valve assembly.
Remove the brazing as shown in the figures with the reversing valves covered with wet cloth for cooling. Remove the brazing in the following order:
- (a) Brazing at the right and left branch pipes of the three pipes coming from the reversing valve.
 - (b) Brazing at the middle branch pipe of the three pipes coming from the reversing valve.
- (8) Set the reversing valves in the reverse procedure.

NOTE:

During brazing work, cover the reversing valves and the stop valves with wet cloth for cooling.

! WARNING

TURN OFF all power source switches.

Tool	Adjustable Wrench or Spanner, Phillips Screwdriver, Burner, Pipe Cutter, Pliers, Pincher, Charging Hose
------	---

<Reversing Valve Position>

- AVWT-76~114HKFXE

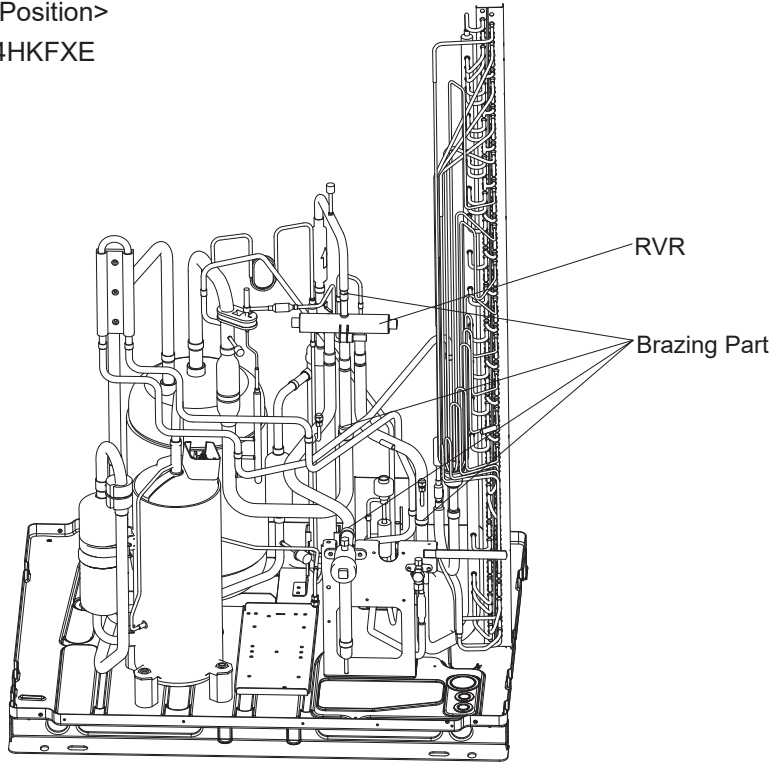

- AVWT-136~190HKFXE

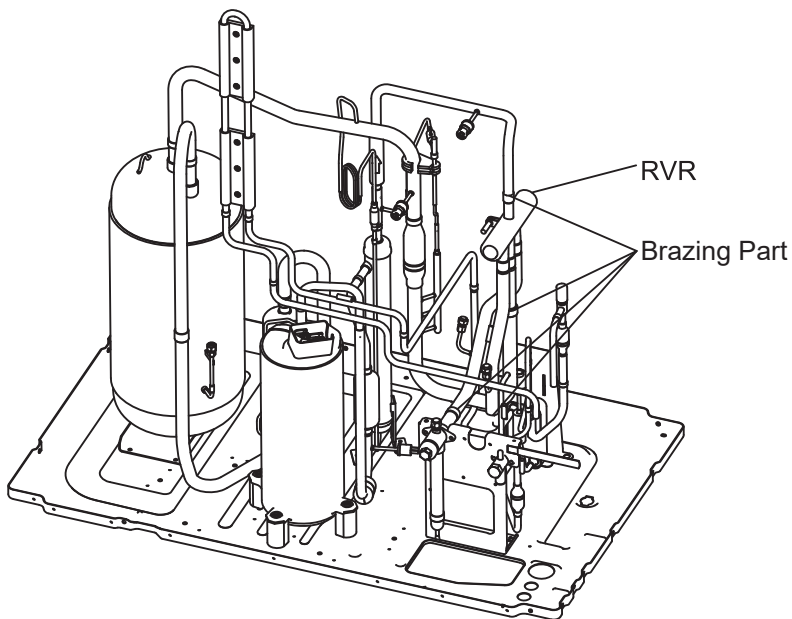

! WARNING

TURN OFF all power source switches.

2.13 Removing Stop Valve

- (1) Remove the front service cover according to the item 2.1 "Removing Front Service Cover".
- (2) Collect all the refrigerant in the refrigerant cycle.
- (3) When removing (A) gas stop valve, cover the stop valves with wet cloth for cooling and then remove the brazing. When removing (B) liquid stop valve, remove the brazing of the pipe for the stop valve as shown in the figure

NOTE:

When removing the brazing for (A) gas stop valve and (B) liquid stop valve, the RC cover should be removed or protected with a metal plate.

- (4) After removing the brazing for the stop valves, remove the screws fixing the plates as shown in the figure and pull out the stop valves and the plates.
- (5) Set the stop valves in the reverse procedure.

NOTE:

When brazing the stop valves or removing the brazing, cover the stop valves with wet cloth for cooling.

The allowable temperature limit of the internal stop valve is 120 °C.

Tool	Wet Cloth, Burner, Pliers, Phillips Screwdriver
------	--

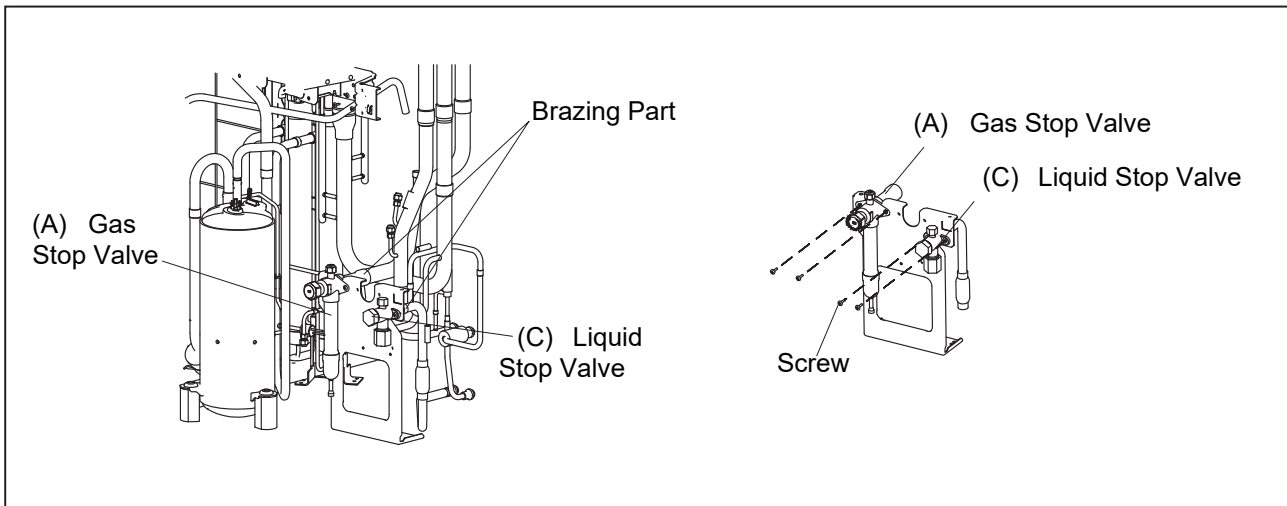

! WARNING

TURN OFF all power source switches.

2.14 Removing High Pressure Switch, High Pressure Sensor, Low Pressure Sensor and Thermistor

- (1) Remove the front service cover according to Item 2.1 "Removing Front Service Cover".
- (2) High Pressure Switch (PSH1 and PSH2), High Pressure Sensor, Low Pressure Sensor and Thermistor (Tg, Tchg, Tbg ,Td and Te) are fixed as shown in the figure below.

Tool	Adjustable Wrench or Spanner
------	------------------------------

<High Pressure Switch, High/Low Pressure Sensor Position>

- AVWT-76~114HKFXE

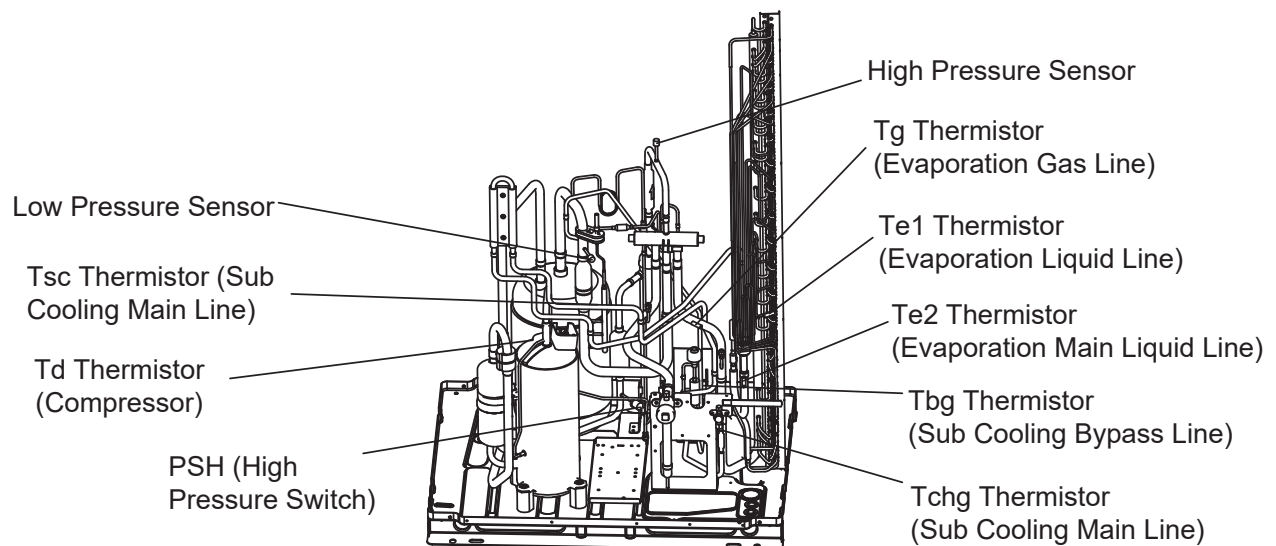

● AVWT-136~170HKFXE

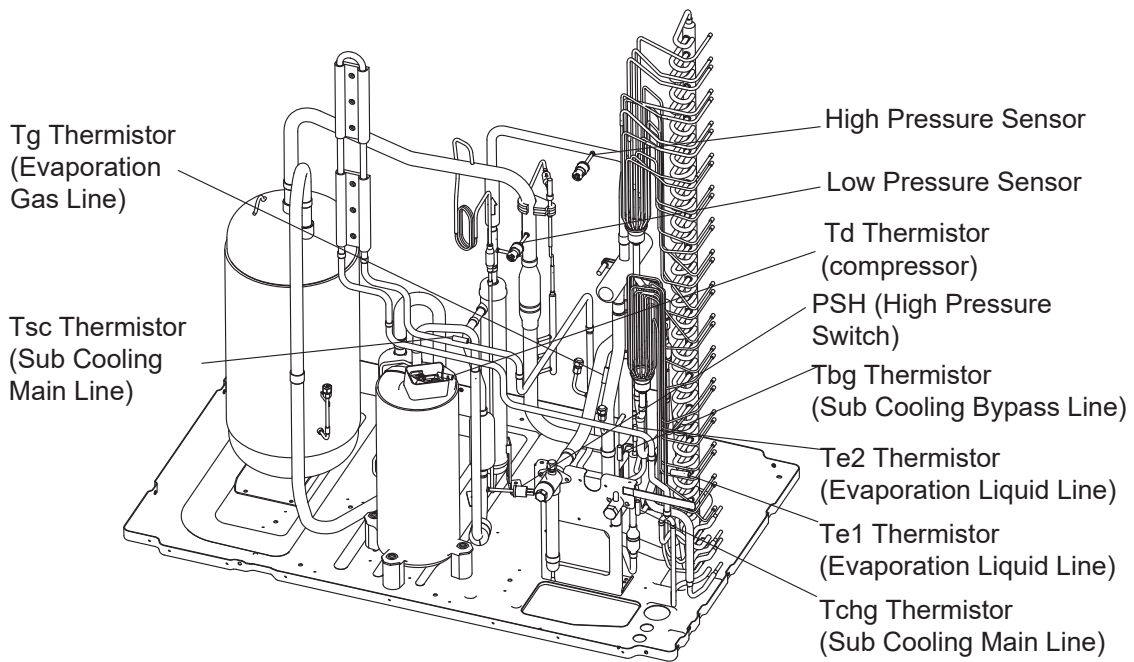

● AVWT-190~272HKFXE

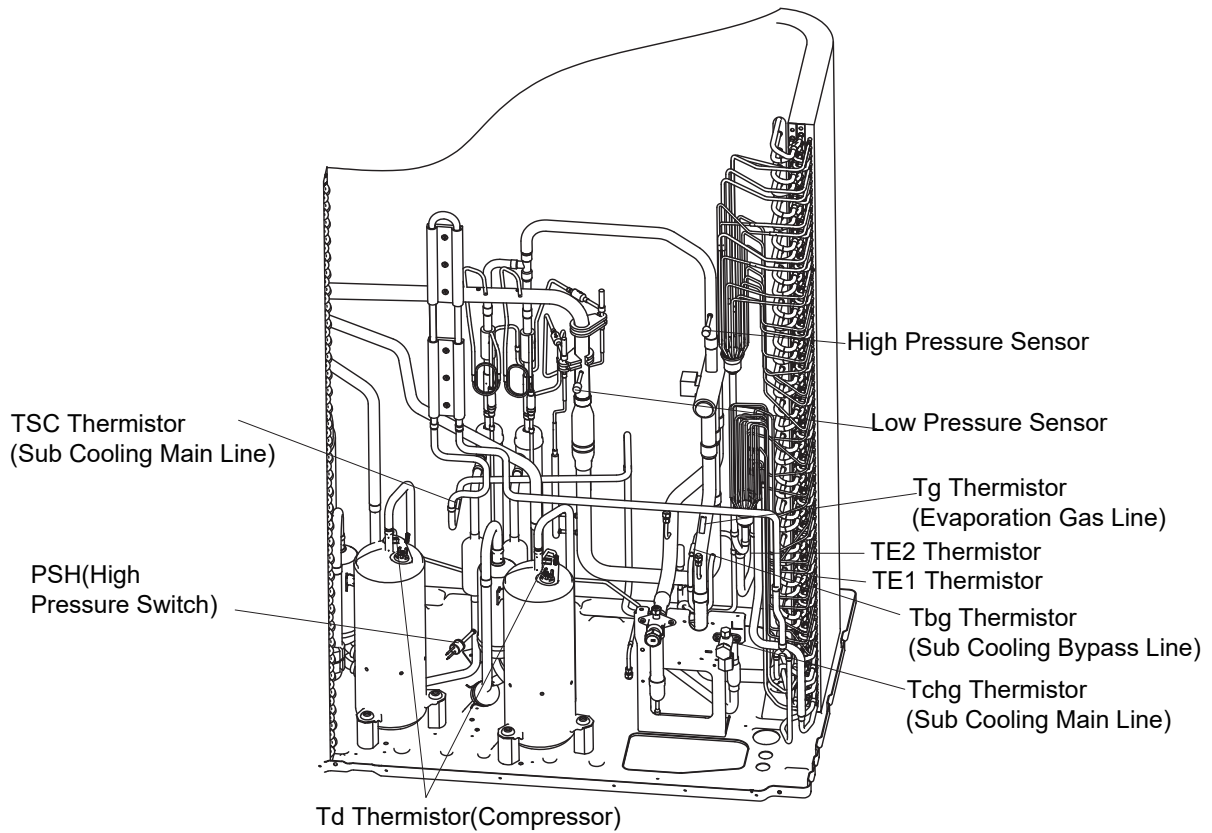

! WARNING

TURN OFF all power source switches.

2.14.1 Removing High Pressure Switch (PSH1 and PSH2)

- (1) Collect the refrigerant.
- (2) Disconnect the faston terminals.
- (3) Remove the high pressure switch from the brazing part of the discharge pipe with a burner.

NOTES:

- To prevent water and foreign particles from entering the refrigerant cycle, mount the new high pressure switch immediately after removing the old one. If it is impossible by necessity, seal the hole with tapes.
- Check that the RC cover inner side (aluminium sheet) does not contact the terminals of the high pressure switch.
- Make sure to fix the insulating sleeve of the faston terminals as shown in the figure.
If the terminals of the high pressure switch are exposed and contact with the RC cover, the electrical components may be damaged.

Tool	Burner, Adjustable Wrench or Spanner, Phillips Screwdriver, Pliers
------	--

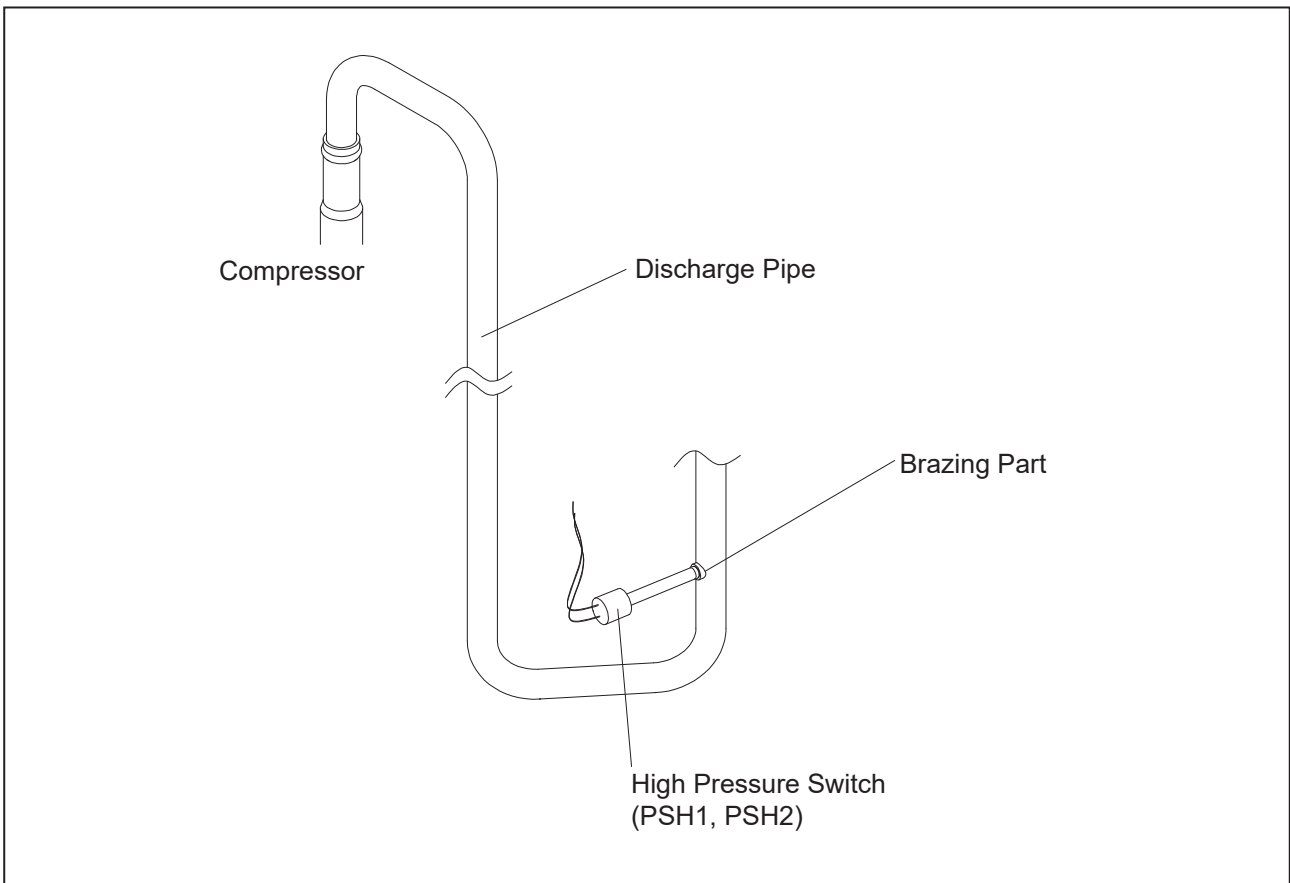

! WARNING

TURN OFF all power source switches.

2.15 Removing Thermistor for Liquid Pipe

- (1) Remove the front service cover according to the item 2.1 "Removing Front Service Cover".
- (2) Remove the electrical box cover according to the item 2.5 "Removing Electrical Box Cover".
- (3) Remove the rubber cemen. Then, remove the thermistor for the liquid pipe by pulling out the thermo clip from the pipe.

NOTE:

When removing the thermistor for the liquid pipe, take special care not to cause damage to your hands or the thermistor with the valve stay fixing the stop valve.

- (4) Reassemble the thermistor for liquid pipe in the reverse procedure.

NOTE: When reassembling the thermistor, fix the thermistor with a water blocking to prevent water from entering the pipe.

Tool	Wet Cloth, Burner, Pliers, Phillips Screwdriver, Nippers
------	---

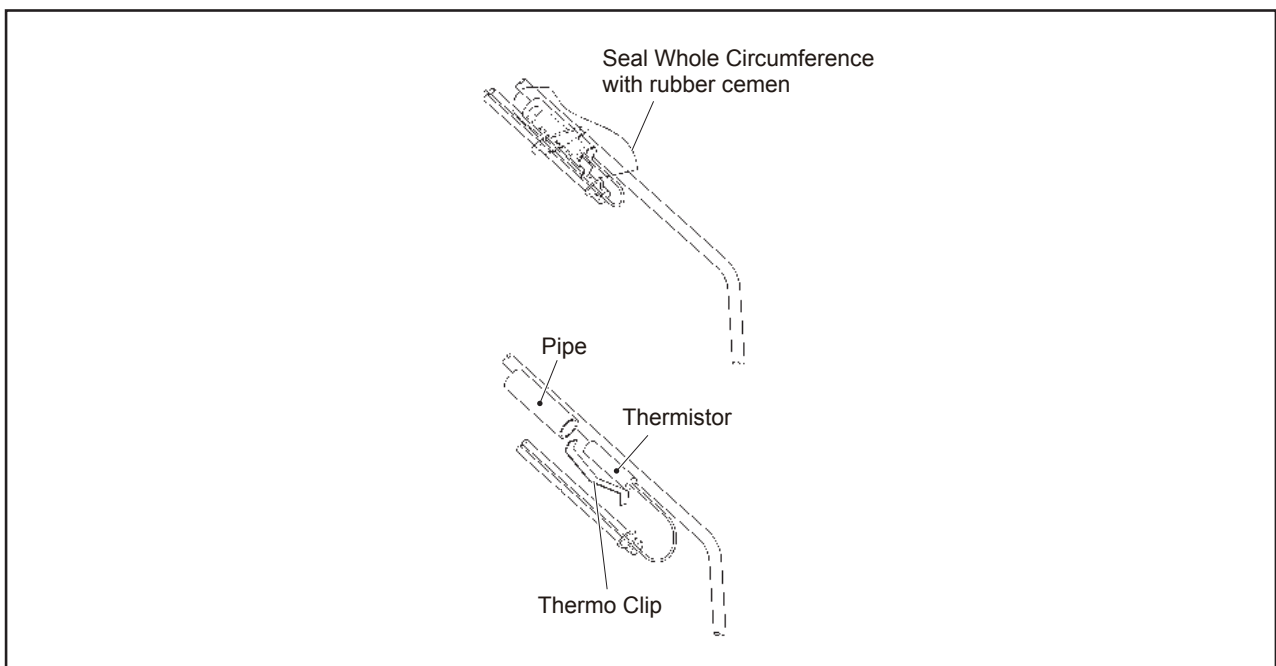

! WARNING

TURN OFF all power source switches.

2.16 Removing Thermistor for Ambient Temperature

- (1) Remove the front service cover according to the item 2.1 "Removing Front Service Cover".
- (2) Remove the electrical box cover according to the item 2.5 "Removing Electrical Box Cover".
- (3) Remove the upper cover according to the item 2.3 "Removing Top Cover".
- (4) Thermistor wiring is fixed at the heat changer, pipings and such. Remove the fixing clamps for the wiring.
- (5) Reassemble the thermistor for ambient temperature in the reverse procedure.

Tool	Phillips Screwdriver, Nippers
------	-------------------------------

<Thermistor Position for Ambient Temperature (Example: AVWT-76HKFXE)>

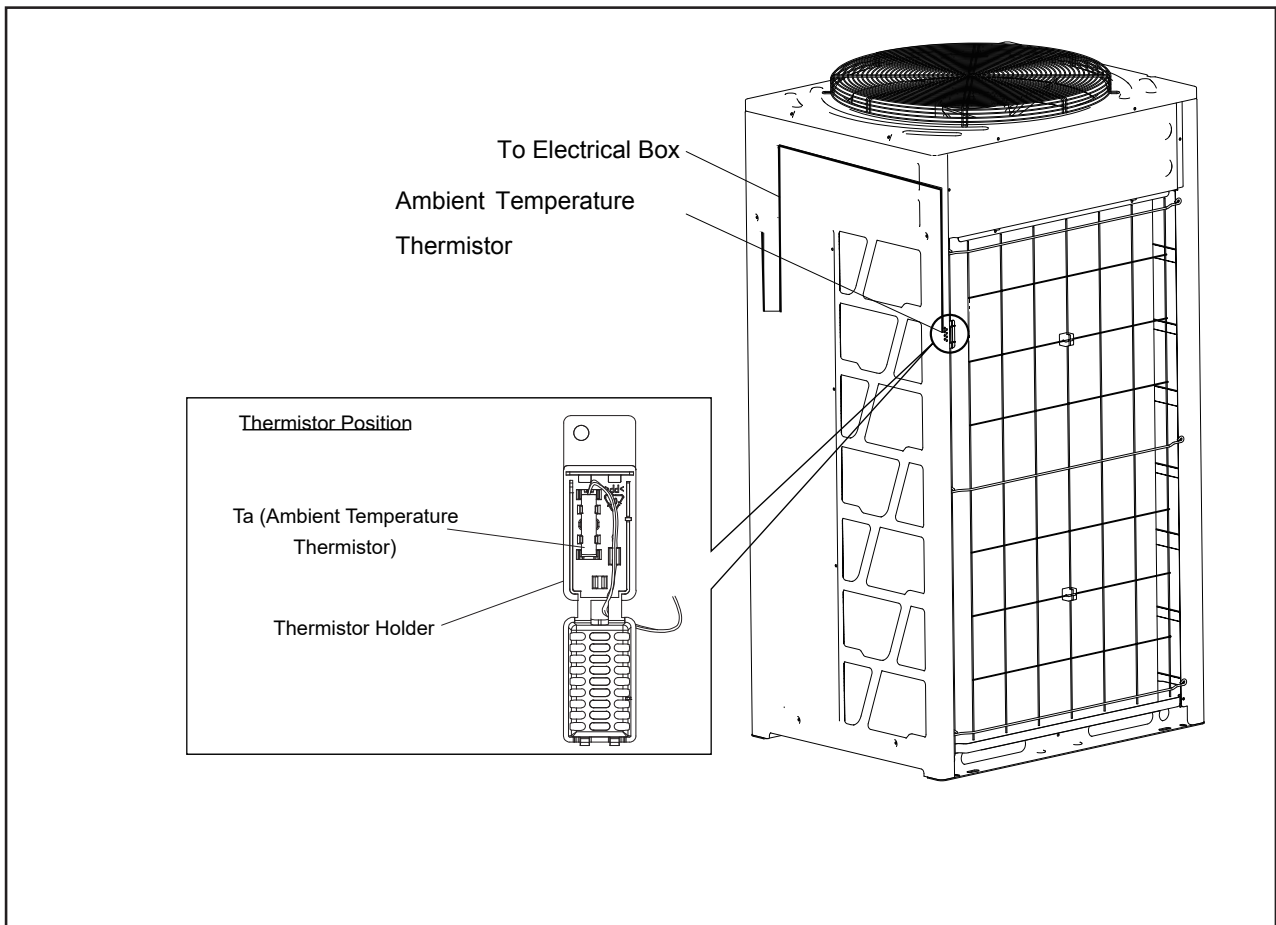



TURN OFF all power source switches.

2.17 Removing Other Electrical Components

NOTES:

- When reassembling the electrical components, match the terminal Nos. with the mark band Nos. . If they are incorrectly connected, malfunction may occur or the electrical components may be damaged.
- When fixing PCBs or sheet metals for outdoor unit PCB, protect the electric wiring from catching on the sheet metals or the electrical components.
- Make sure to use screws, bushes and collars when fixing inverter PCBs.
If not, it may cause equipment malfunction.
- When replacing the outdoor unit PCB, set the dip switches in the same way as before the outdoor unit PCB replacement. Incorrect setting will cause malfunction. Refer to the instruction manual attached to servicing outdoor unit PCB.
- Do not apply an excessive force to the electrical components on PCBs or PCBs themselves. It may lead to PCBs failure.
- When replacing the fan controller, set the dip switches in the same way as before the fan controller replacement. Incorrect setting will cause malfunction.

! WARNING

TURN OFF all power source switches.

2.17.1 Removing Outdoor Unit PCB and Electrical Components for Electrical Box

< Removing Outdoor Unit PCB >

- (1) Remove all the connectors for wiring connected to the outdoor unit PCB.
- (2) Put your hand on the buckle, then, Push the buckle outward, Remove the outdoor unit PCB. (Refer to fig 1)

< Opening Outdoor Unit PCB Fixing Plate >

- (1) Remove all the wirings connected with the electrical components.
- (2) When checking or replacing the Noise Filter, remove screws (4 places) at Part B in the figure and open the outdoor unit PCB fixing plate.
- (3) When removing the fixing plate for outdoor unit PCB, all the connectors connected with the outdoor unit PCB should be removed.

< Removing Electrical Components >

- (1) Remove all the wirings connected with the electrical components
- (2) Remove the screws fixing the electrical components.

NOTES:

- Do not touch the electrical components on the outdoor unit PCBs.
- Do not bend the outdoor unit PCB by applying an excessive force to it. Otherwise, it will cause outdoor unit PCB failure.
- When reassembling the electrical components, match the terminal Nos. with the mark band Nos. If they are incorrectly connected, malfunction may occur or the electrical components may be damaged.
- When closing the outdoor unit PCB fixing plate for reassembly, protect the cables from catching on the plate edges or electrical components.
- The capacitor is charged with electricity even when the power source is turned off.
- DO NOT touch the terminals, to avoid an electric shock.

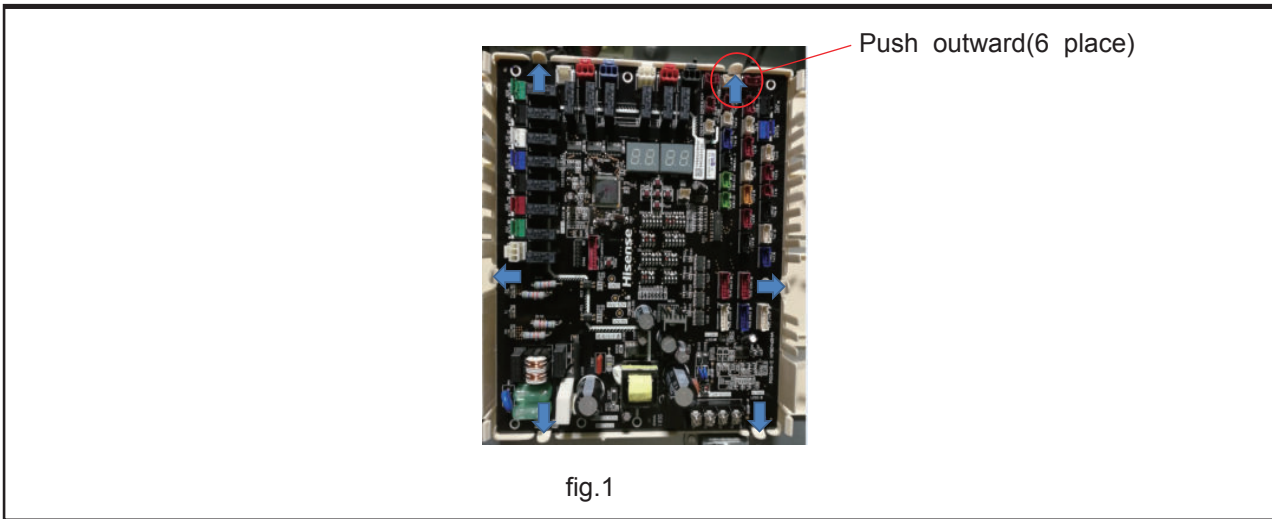

! WARNING

TURN OFF all power source switches.

Tool	Phillips Screwdriver, Long-Nose Pliers, Pliers
------	---

● AVWT-76~114HKFXE

● AVWT-136~170HKFXE

Front Side (For Main)

B (Screw for Outdoor Unit PCB Fixing Plate)

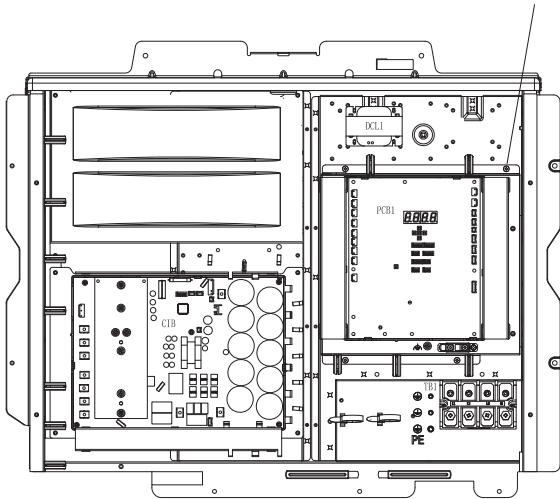

Front Side (For Main)

B (Screw for Outdoor Unit PCB Fixing Plate)

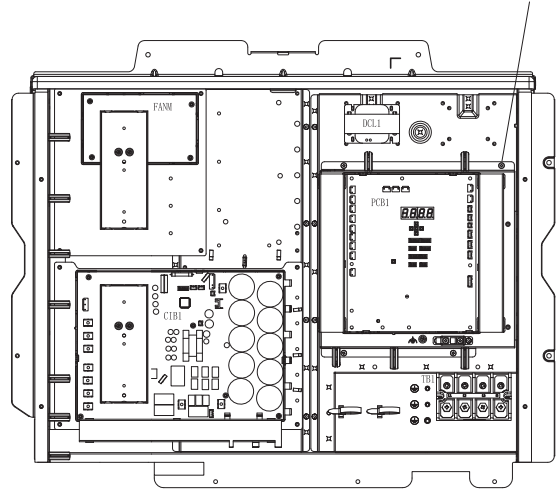

The Interior of the Electrical Box (For Main)

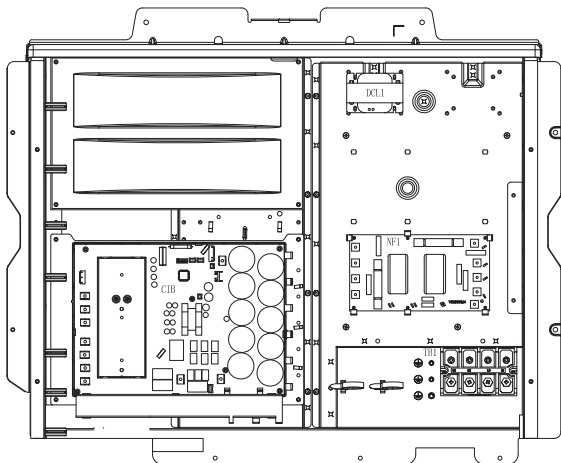

The Interior of the Electrical Box (For Main)

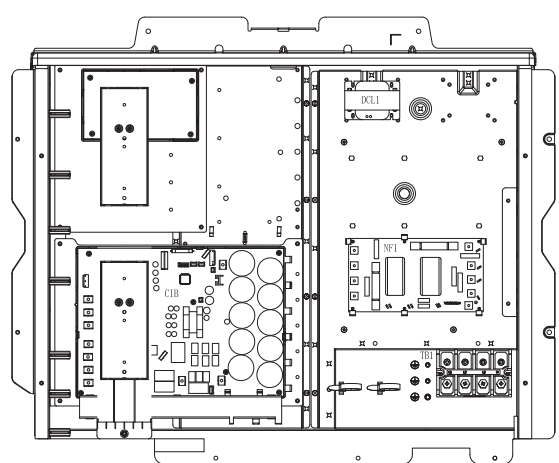

●AVWT-190~272HKFXE

Front Side (For Main)

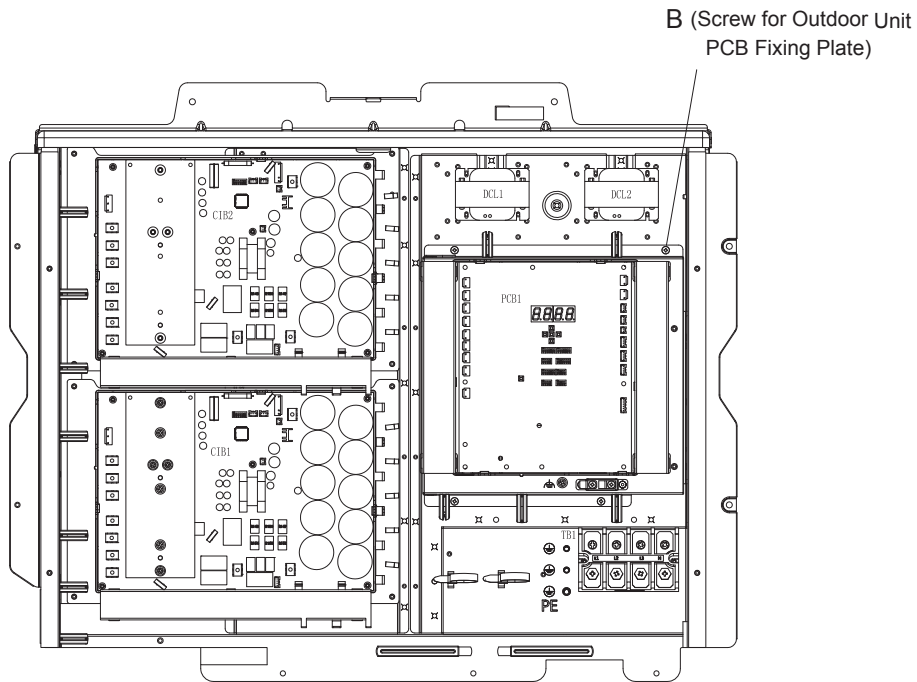

The Interior of the Electrical Box (For Main)

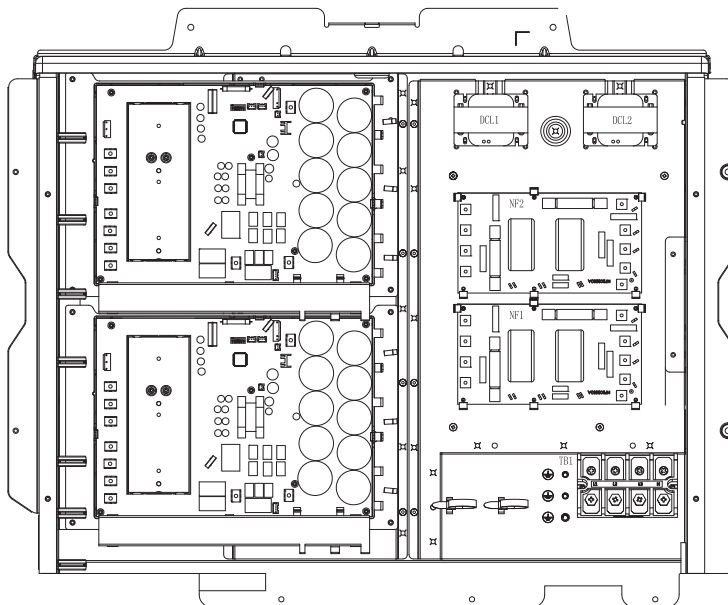

Item	Part Name	Item	Part Name
PCB	Outdoor Unit PCB	Invert PCB1/PCB2	Inverter PCB
NF1,2	Noise Filter	FANM	Fan Controller
TB1	Terminal Board	DCL1, 2	Reactor

! WARNING

Turn OFF all power source switches.
 Do not touch any electrical components while LED3 (Red) on Inverter PCB is ON.
 Otherwise, an electric shock will occur.

2.17.2 Removing Inverter PCB

- (1) Disconnect all the wirings connected to the CN3, CN4, CN5, CN206, CN207, PCN1, PCN2, DCL.
- (2) Disconnect the wirings for the Inverter PCB (U,V,W,T,S,R,N,DCL1,DCL2).
- (3) After removing for four (4) screws, remove the inverter PCB.

NOTE:

Do not touch any electrical components while LED3 (red) of inverter PCB is ON. Otherwise, it may lead to an electric shock.

NOTES:

1. When reassembling the electrical components, match the terminal Nos. with the mark band Nos. If they are incorrectly connected, malfunction may occur or the electrical components may be damaged.
2. When closing the outdoor unit PCB fixing plate for reassembly, protect the cables from catching on the plate edges or electrical components.

Tool	Phillips Screwdriver
------	----------------------

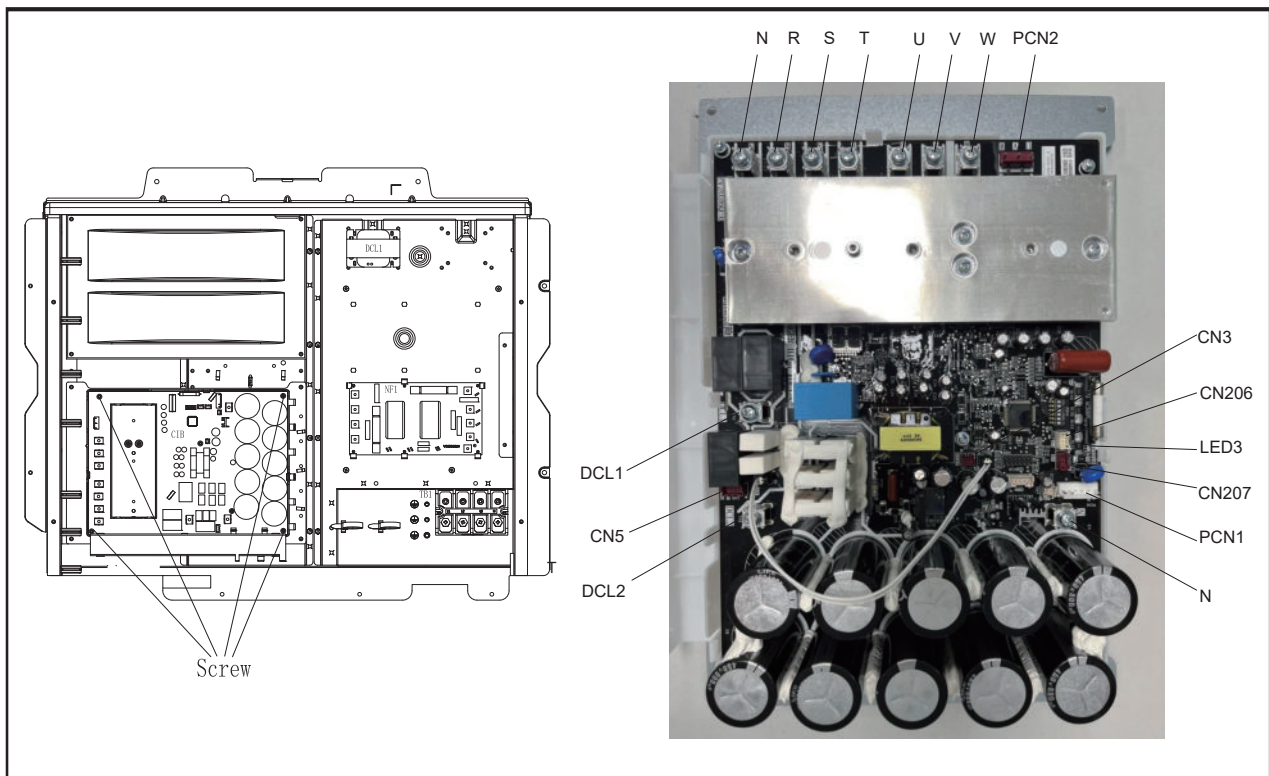

! WARNING

TURN OFF all power source switches.

2.17.3 Mount the electrical box in the reverse procedure.

NOTES:

- Check to ensure that the tube end of waterproof vinyl pipe and the connectors are in the electrical box. Fix them firmly with a cord clamp when wiring up as shown in the figure below.
- Fix the wiring connecting each electrical part and the electrical box with a plastic band to avoid direct contact with the compressor, piping and plate edges.
- Fix the wiring neatly with a cord clamp and make sure that the wiring will not be held down by the electrical box cover. Otherwise, the wiring may be damaged while the cover is closed.
- Fix the fan motor wiring with a cord clamp as shown in the figure.

NOTES:

1. When reassembling the electrical component, match the terminal Nos. with the mark band Nos. If they are incorrectly connected, malfunction may occur or the electrical components may be damaged.
2. The setting of dip switches differs according to the model. When replacing the outdoor unit PCB, refer to "Outdoor Unit PCB" in 1.1.2 Checking of Rotary Switch and Dip Switch Setting.

Tool	Phillips Screwdriver, Pincher
------	-------------------------------

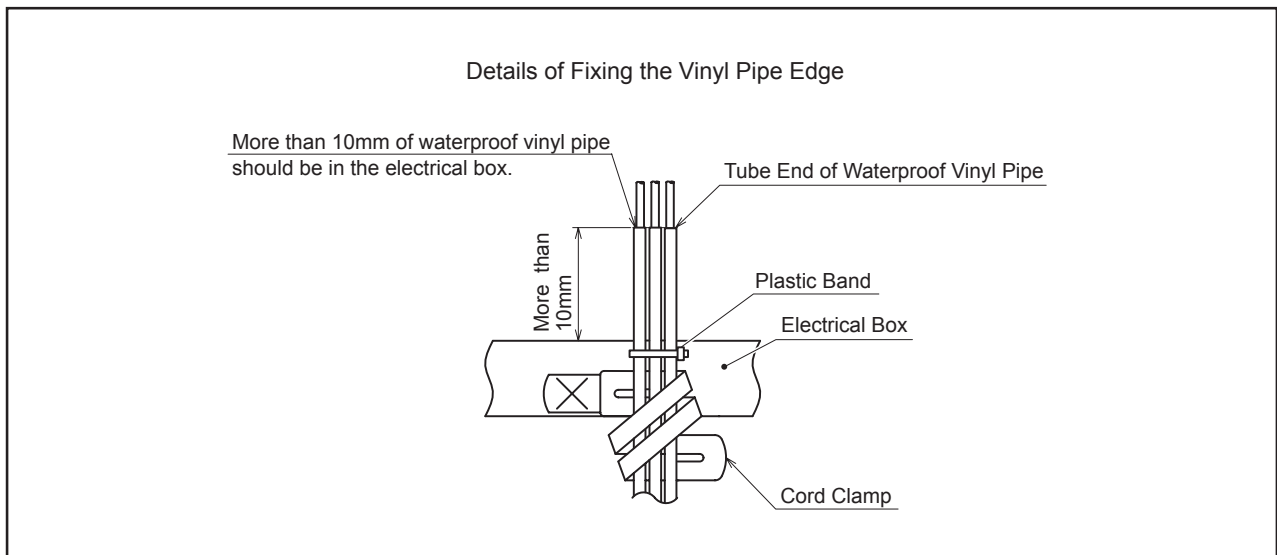

3. Main Parts

3.1 Inverter

3.1.1 Specifications of Inverter

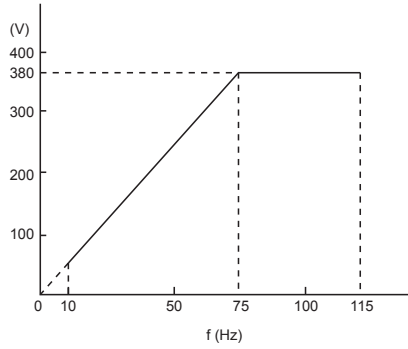
Applicable Power Source		3 Phase, 380-415V, 50/60Hz
Output Voltage (Maximum)		380-415V
Output Current (Maximum)	Inverter PCB	25A(76/96/190 Model) 38A(114~170; 212~272 Model)
	Fan Controller	3.2A
Control Method		Vector PWM Control
Range Output Frequency	Inverter PCB	15 - 120Hz
	Fan Controller	0 - 21Hz
Accuracy of Frequency		0.01Hz
Output / Characteristics		<p>Conditions: 1. Power Source Voltage AC 380V 2. Non-Loading (Free Output)</p> <p>(In Case of 380V)</p>  <p>NOTE: Characteristics are fluctuated by the current minimal control.</p>
Soft Start Stop		0.125Hz/S, 0.25Hz/S, 0.5Hz/S, 1Hz/S, 3Hz/S (5 Steps)
Protection Function Excessive High or Low Voltage for Inverter		In Case of 380-415V Excessive Low Voltage at a DC Voltage is Lower than 388V Excessive High Voltage at a DC Voltage is Higher than 752V
Abnormality of Current Sensor		Stoppage at a current of compressor smaller than 1.5A Cause of Abnormality: Failure of Current Sensor Failure of Power Integrated Module Failure of Compressor Disconnected Wiring

<p>Protection Function Overcurrent Protection for Inverter</p>	<p>(1) Short-Circuit Trip of Arm (2) Instantaneous Overcurrent Trip (3) Instantaneous Overcurrent Trip (4) Electronic Thermal Trip</p> <p>When detecting current is more than rated current of Power Integrated Module, overcurrent is detected. When the current detected by current sensor exceeds 105% of the rated current continuously for 30 seconds or for 3 minutes in total during a 10-minute period, overcurrent is detected.</p>
<p>Protection of Power Integrated Module (PIM)</p>	<p>Power Integrated module (PIM) has four protection functions for self-protection.</p> <p>(1) Some of the output terminals between "U" and "V", "V" and "W", "W" and "U" have a short-circuit. (2) Running current reaches the maximum rated current. (3) Abnormal temperature is measured by internal thermistor. (4) Control voltage decreases abnormally.</p>
<p>Overload Control</p>	<p>Overload control at a current greater than (Rated Current x 105%). Overload control release at a current smaller than (Rated Current x 88%).</p>
<p>Case Temperature Increase</p>	<p>The unit is stopped when the PIM Tc temperature is higher than 100°C.</p>
<p>Earth Detection</p>	<p>The unit is stopped when the compressor is earthing.</p>

3.1.2 Arrangement of Inverter Power Unit

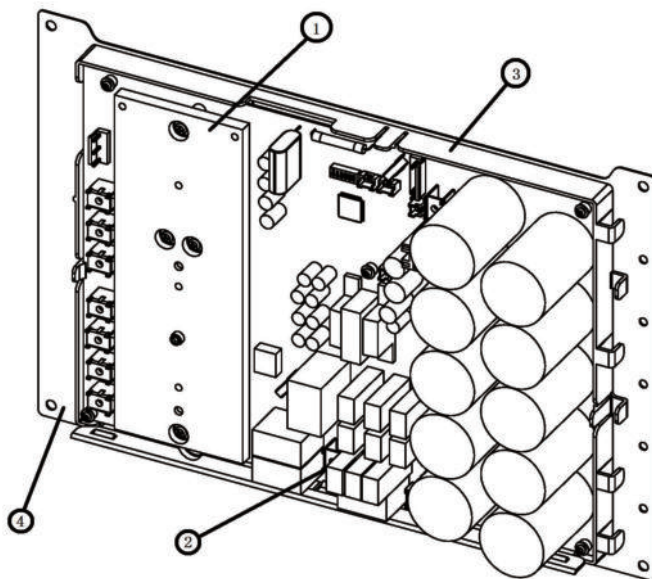

No.	Parts Name
1	Radiation Fin
2	Inverter PCB
3	Plastic Support
4	Mounting Plate

3.1.3 Protective Function

(1) Excessive High or Low Voltage for Inverter

(a) Level of Detection

In case of 380-415V/50Hz, 380V/60Hz

When the voltage of direct current is greater than 752V, abnormalities are detected.

When the voltage of direct current is smaller than 328V, abnormalities are detected.

(b) Function

When abnormalities are detected, the inverter compressor is stopped and transmit the signal code of stoppage cause to outdoor unit PCB.

(c) Cancellation of Protection Function

Transmission signal about stoppage cause is canceled when remote control switch is off or main power source is cut off.

(2) Abnormality of Current Sensor

(a) Level of Detection

① When the compressor operating frequency is between 15Hz and 18Hz after compressor is started, one of the effective value of running current at each phase is less than 1.5A (including 1.5A).

② The wave height value of running current for the phase positioning is less than 5A before the compressor is started (at completing the phase positioning).

(b) Function

When abnormalities are detected, the inverter compressor is stopped, and transmit the signal code of stoppage cause to outdoor unit PCB.

(c) Cancellation of Protection Function

Transmission signal about stoppage cause is canceled when remote control switch is off or main power source is cut off.

(3) Overcurrent Protection for Inverter

(a) Level of Detection

① When the compressor current detected by current sensor exceeds the rated current of Power Integrated module (PIM), overcurrent is detected. (Instantaneous Overcurrent)

② When the current detected by current sensor exceeds 105% of the rated current continuously for 30 seconds or for 3 minutes in total during a 10-minute period, overcurrent is detected. (Electric Thermal Relay)

(b) Function

When abnormalities are detected, the inverter compressor is stopped and transmit the signal code of stoppage cause to outdoor unit PCB.

(c) Cancellation of Protection Function

Transmission signal about stoppage cause is canceled when remote control switch is off or main power source is cut off.

(4) Protection of Power Integrated Module (PIM)

(a) Level of Detection

① When some of the output terminals between "U" and "V", "V" and "W", "W" and "U" of Power Integrated module (IPM) are short-circuited, an abnormality is detected.

② When the running current of transistor module (PM) reaches the maximum rated current, an abnormality is detected.

③ When abnormal increase in temperature is measured by thermistor with internal Power Integrated module (PIM), an abnormality is detected.

④ When the control voltage of Power Integrated module (PIM) abnormally decreases, an abnormality is detected.

(b) Function

When abnormalities are detected, the inverter compressor is stopped and the signal code of stoppage cause is transmitted to outdoor unit PCB.

(c) Cancellation of Protection Function

Transmission signal about stoppage cause is canceled when remote control switch is off or main power source is cut off.

(5) Case Temperature Increase

(a) Level of Detection

When the temperature of internal thermistor exceeds 100°C, an abnormality is detected.

(b) Function

When abnormalities are detected, the inverter compressor is stopped and the signal code of stoppage cause is transmitted to outdoor unit PCB.

(c) Cancellation of Protection Function

Transmission signal about stoppage cause is canceled when remote control switch is off or main power source is cut off.

(6) Earth Detection

(a) Level of Detection

① When the terminal U, V, W and earth of the compressor are short-circuited before compressor activation, abnormalities are detected.

② When the output terminals (U, V, W) of transistor module (PIM) are short-circuited, abnormalities are detected.

(b) Function

When abnormalities are detected, the inverter compressor is stopped and the signal code of stoppage cause is transmitted to outdoor unit PCB.

(c) Cancellation of Protection Function

Transmission signal about stoppage cause is canceled when remote control switch is off or main power source is cut off.

3.1.4 Overload Protection Control

(a) Level of Detection

When the output current exceeds 105% of the maximum output current, an abnormality is detected.

(b) Function

An overload signal is transmitted to the outdoor unit PCB when output current exceeds 105% of the maximum output current, and the frequency decreases.

For 10 seconds after the output current decreases lower than 88% of the rated current, the compressor maximum frequency is limited to the specified value.

However, if the frequency order is smaller than the maximum value, the operation is performed according to the order.

(c) Cancellation of Protection Function

After the operation described in the above item (b) is performed for 10 seconds, this control is canceled.

3.2 Electronic Expansion Valve

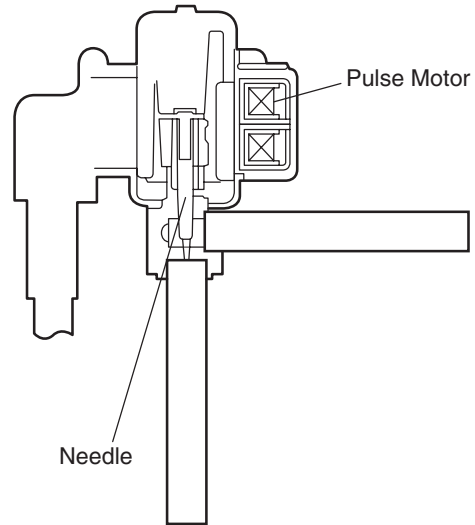
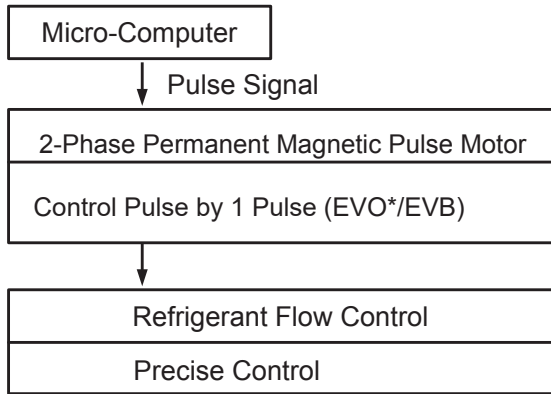

EVO*:	Model	Pulse
	76~114	0 to 480
	136~272	0 to 3000

Specification

Items	Specification																																																																								
	For Main Cycle (EVO) Model:76~114	For Bypass Line (EVB)	For Main Cycle (EVO) Model:136~272																																																																						
Type	UKV Series		PAM Series																																																																						
Refrigerant Used	R410A																																																																								
Working Temperature Range	-30°C - 70°C																																																																								
Mounting Direction	Drive shaft in Vertical Direction within an Angle of 45° as Maximum																																																																								
Flow Direction	Reversible																																																																								
Rated Voltage	DC12V+1.2V																																																																								
Drive Condition	80 ± 5 PPS 1-2 Phase Excitation	80 ± 5 PPS 1-2 Phase Excitation	100~200 PPS 2-2 Phase Excitation																																																																						
Coil Resistance	46Ω ± 3Ω (at 20°C)		100Ω ± 10Ω																																																																						
Wiring Diagram, Drive Circuit and Activation Mode	<table border="1"> <thead> <tr> <th>Phase</th> <th>1</th> <th>2</th> <th>3</th> <th>4</th> <th>5</th> <th>6</th> <th>7</th> <th>8</th> </tr> </thead> <tbody> <tr> <td>φ 1</td> <td>ON</td> <td>ON</td> <td>OFF</td> <td>OFF</td> <td>OFF</td> <td>OFF</td> <td>OFF</td> <td>ON</td> </tr> <tr> <td>φ 2</td> <td>OFF</td> <td>OFF</td> <td>OFF</td> <td>OFF</td> <td>OFF</td> <td>ON</td> <td>ON</td> <td>ON</td> </tr> <tr> <td>φ 3</td> <td>OFF</td> <td>OFF</td> <td>OFF</td> <td>ON</td> <td>ON</td> <td>ON</td> <td>OFF</td> <td>OFF</td> </tr> <tr> <td>φ 4</td> <td>OFF</td> <td>ON</td> <td>ON</td> <td>ON</td> <td>OFF</td> <td>OFF</td> <td>OFF</td> <td>OFF</td> </tr> </tbody> </table> <p>OPEN: 1 → 2 → 3 → 4 → 5 → 6 → 7 → 8 CLOSE: 8 → 7 → 6 → 5 → 4 → 3 → 2 → 1</p>		Phase	1	2	3	4	5	6	7	8	φ 1	ON	ON	OFF	OFF	OFF	OFF	OFF	ON	φ 2	OFF	OFF	OFF	OFF	OFF	ON	ON	ON	φ 3	OFF	OFF	OFF	ON	ON	ON	OFF	OFF	φ 4	OFF	ON	ON	ON	OFF	OFF	OFF	OFF	<table border="1"> <thead> <tr> <th>Phase</th> <th>1</th> <th>2</th> <th>3</th> <th>4</th> </tr> </thead> <tbody> <tr> <td>φ1</td> <td>ON</td> <td>OFF</td> <td>OFF</td> <td>ON</td> </tr> <tr> <td>φ2</td> <td>ON</td> <td>ON</td> <td>OFF</td> <td>OFF</td> </tr> <tr> <td>φ3</td> <td>OFF</td> <td>ON</td> <td>ON</td> <td>OFF</td> </tr> <tr> <td>φ4</td> <td>OFF</td> <td>OFF</td> <td>ON</td> <td>ON</td> </tr> </tbody> </table> <p>OPEN: 4 → 3 → 2 → 1 → 4 CLOSE: 1 → 2 → 3 → 4 → 1</p>	Phase	1	2	3	4	φ1	ON	OFF	OFF	ON	φ2	ON	ON	OFF	OFF	φ3	OFF	ON	ON	OFF	φ4	OFF	OFF	ON	ON
Phase	1	2	3	4	5	6	7	8																																																																	
φ 1	ON	ON	OFF	OFF	OFF	OFF	OFF	ON																																																																	
φ 2	OFF	OFF	OFF	OFF	OFF	ON	ON	ON																																																																	
φ 3	OFF	OFF	OFF	ON	ON	ON	OFF	OFF																																																																	
φ 4	OFF	ON	ON	ON	OFF	OFF	OFF	OFF																																																																	
Phase	1	2	3	4																																																																					
φ1	ON	OFF	OFF	ON																																																																					
φ2	ON	ON	OFF	OFF																																																																					
φ3	OFF	ON	ON	OFF																																																																					
φ4	OFF	OFF	ON	ON																																																																					

3.3 Pressure Sensor

(1) High Pressure Control

The high pressure during heating operation is detected by a high pressure sensor, and compressor frequencies are controlled by the proportional controlling method with operating capacity of indoor units (or PID Control for Compressor Frequency) so that the high pressure is controlled in an appropriate range. The output of the high pressure sensor during heating operation performs protective control; gas by-pass control.

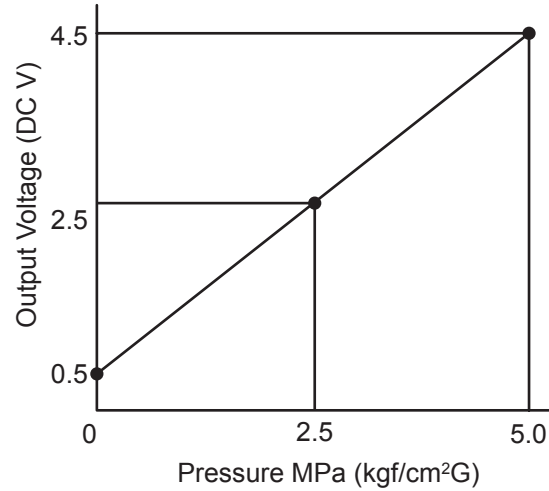
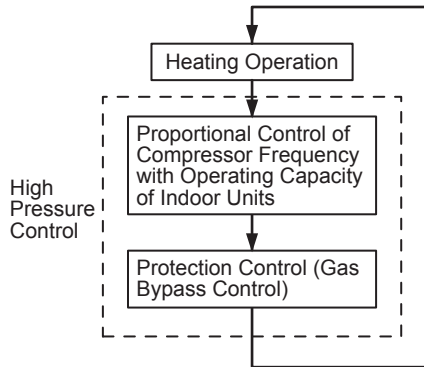

Output Characteristics of High Pressure Sensor

(2) Low Pressure Control

The suction pressure during cooling operation is detected by a low pressure sensor, and compressor frequencies are controlled by the proportional controlling method with operating capacity of indoor units (or PID Control for Compressor Frequency) so that the suction pressure is controlled in an appropriate range. If the suction pressure is excessively low, the cooling can be insufficient and parts composing the refrigeration cycle can be damaged. For this reason, if the output of the low pressure sensor indicates vacuum and the value is maintained for 12 minutes or longer, the compressor is stopped for the purpose of protection.

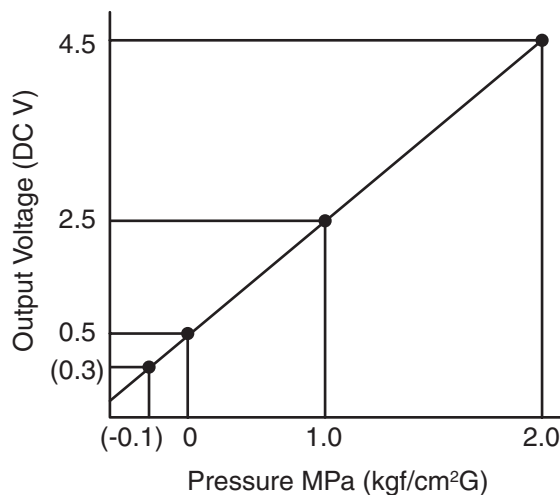
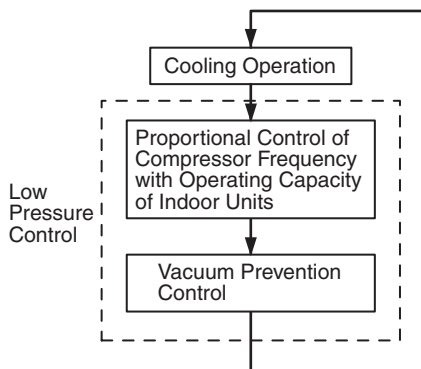

Output Characteristics of Low Pressure Sensor

3.4 Noise Filter (NF1, NF2)

The noise filter decreases the leakage of noise made by the inverter to the power supply side. Terminals indicated with "OUTPUT" are connected to the inverter side and terminals indicated with "INPUT" to the power supply side.

380-415V 3N~50/60Hz

Items	Specification
Model	NFT-037C12-HHBO
Applicable Model	76/96 Model
Rated Current	37A
Permissible Temperature Range	-25°C to +65°C
Circuit Diagram	

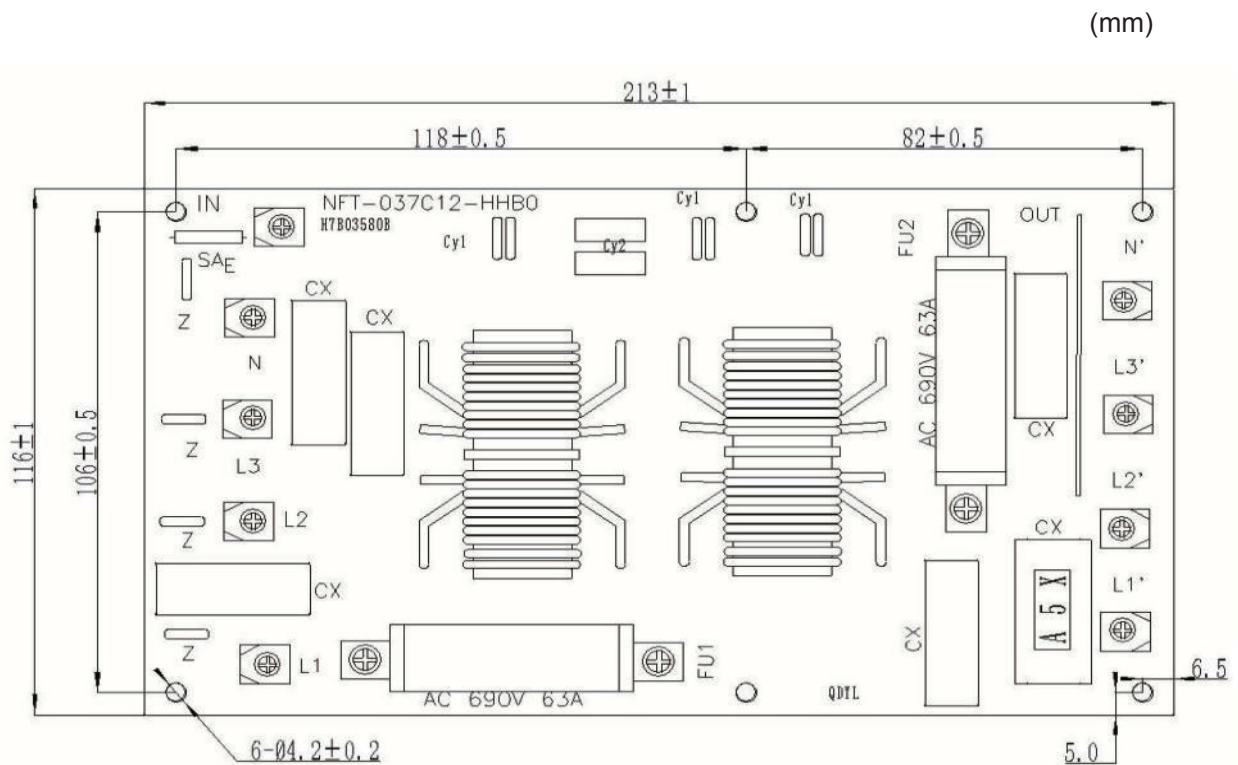

Main Parts

380-415V 3N~50/60Hz

Items	Specification
Model	NFT-037C12-HHCO
Applicable Model	114~272 Model
Rated Current	40A
Permissible Temperature Range	-25°C to +65°C
Circuit Diagram	

(mm)

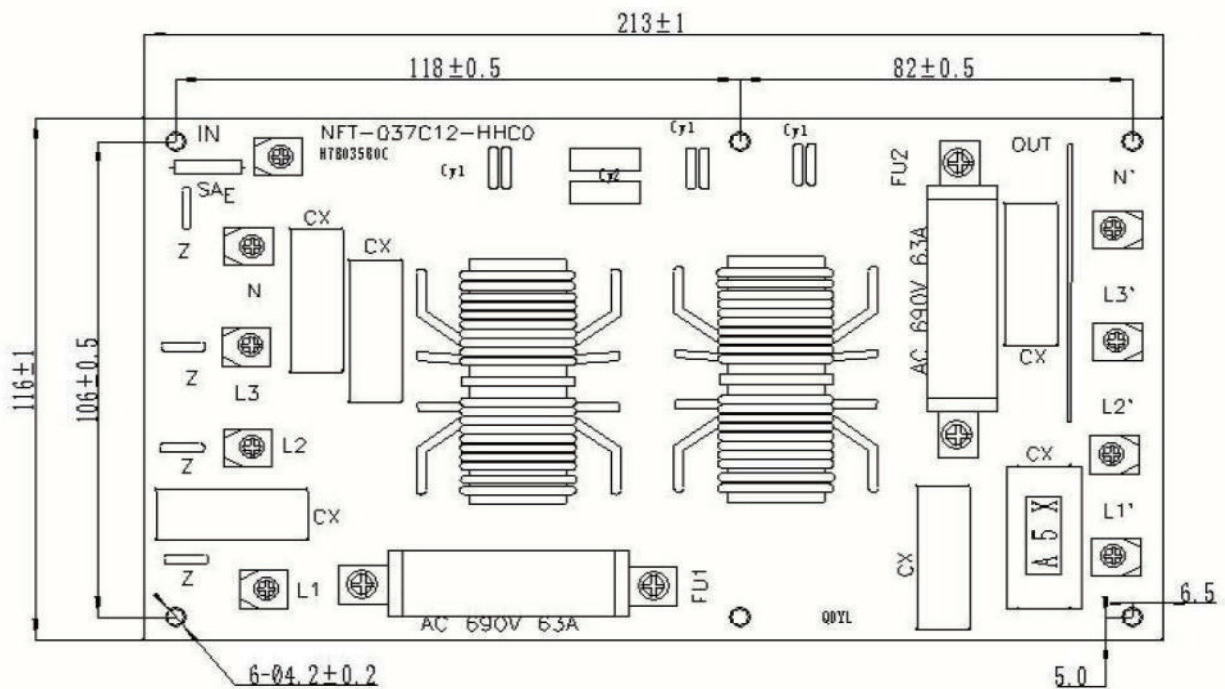

3.5 Reactor (DCL1,DCL2)

This part is used for changing the alternative current to the direct current for the inverter.

380-415V 3N~50/60Hz

Items	Specification
Applicable Model	76~272 Model
Character	1.85mH±15% at 1 kHz
Rated Current	40A
Direct Current Resistance	26mΩ±10% at 20°C
Permissible Tempeture Range	Max. 130°C

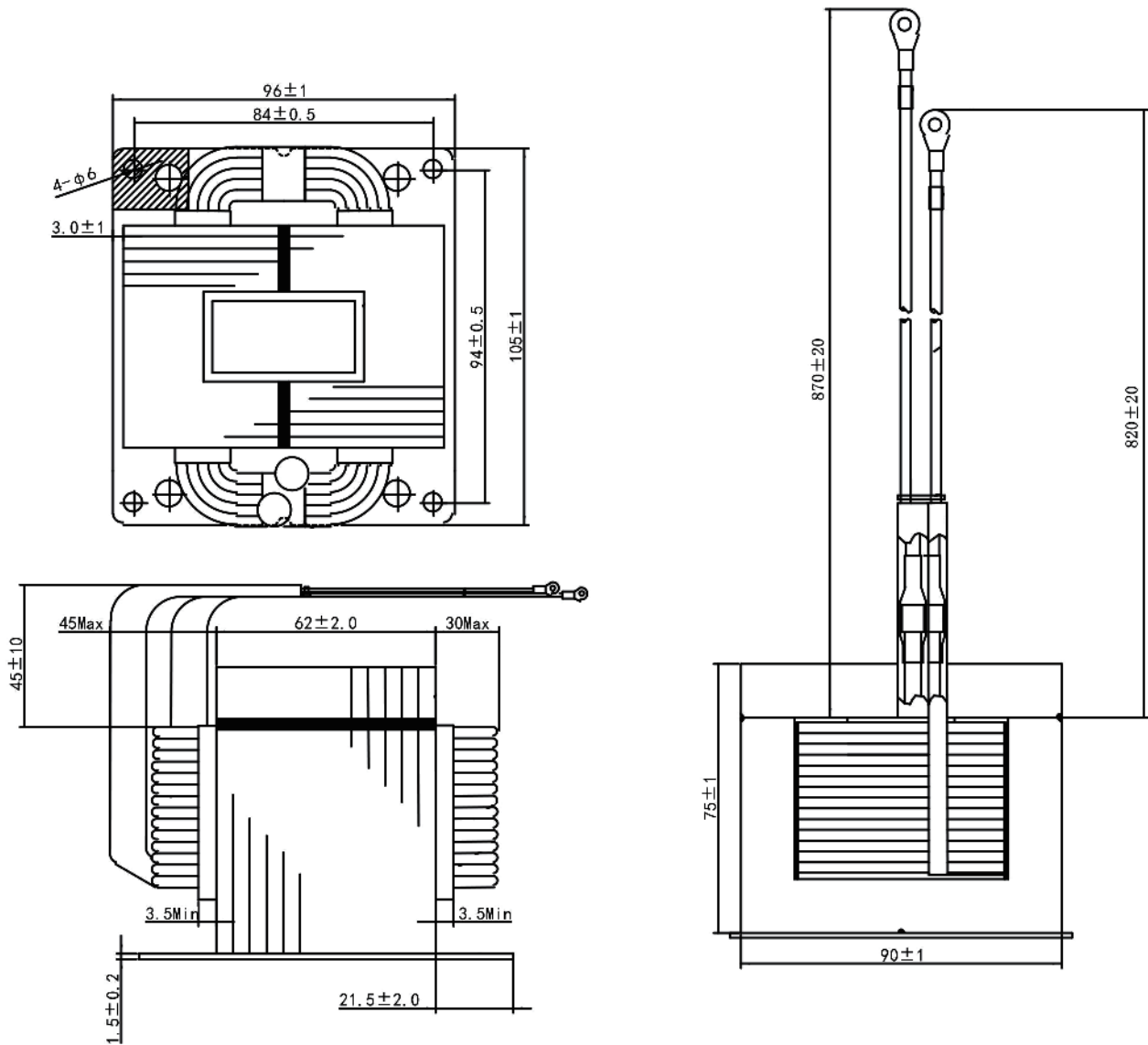

4. Optional Function

4.1 Setting Method

Setting PSW on the outdoor unit PCB is required for “External Input and Output Setting” and “Function Setting”. As for combination of outdoor units, this must be set from the PSW in outdoor unit A. (Setting from the PSW in outdoor unit B,C and D is invalid.) After the setting is completed, press PSW1 for 3 seconds when “Menu Mode” is indicated. The display will be back to the normal indication.

< Setting Method >

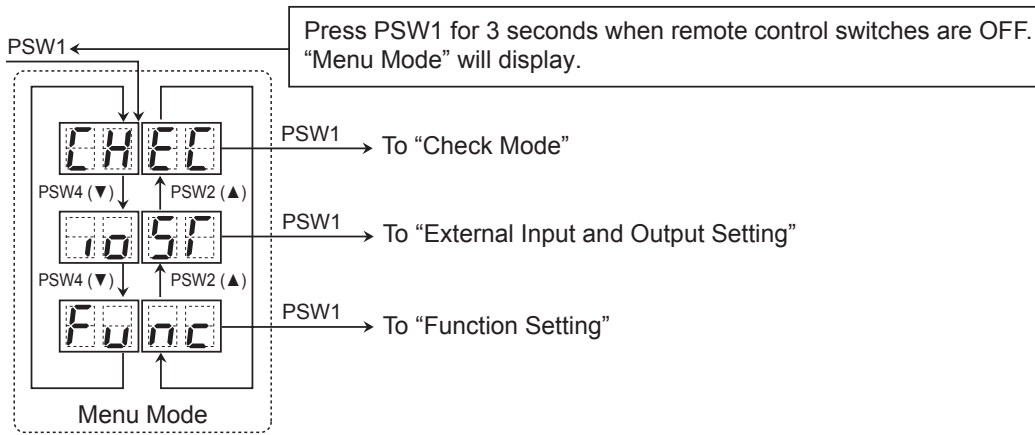

In the menu mode, the followings can be selected.

- (1) Check Mode:
It indicates the alarm code history for outdoor unit and indoor unit. It is mainly used at service. Refer to the "Checking of Alarm Code History" for the detail of check mode.
- (2) External Input and Output Setting:
It is used to set the functions by the external input and output signals.
- (3) Function Setting:
It is used to set the change of operating target, night-shift, etc.

4.2 External Input and Output Setting

On the outdoor unit PCB, there are three input terminals (CN17, CN18) to receive external signals and two output terminals (CN16) to send signals outwards. Control functions shown in the table below are available by setting input and output terminals.

<Input>

Control Function No.	Setting Function for Input
1	Fixing Heating Operation Mode
2	Fixing Cooling Operation Mode
3	Demand Stoppage
4	Outdoor Fan Motor Start/Stop
5	Forced Stoppage
6	Demand Current Control 40%
7	Demand Current Control 60%
8	Demand Current Control 70%
9	Demand Current Control 80%
10	Demand Current Control 100%
11	Low Noise Setting 1
12	Low Noise Setting 2
13	Low Noise Setting 3
0	No Setting

<Output>

Control Function No.	Setting Function for Output
1	Operation Signal
2	Alarm Signal
3	Compressor ON Signal
4	Defrosting Signal
0	No Setting

The following functions have been already set before shipment.

<Input Terminal>

Input Terminal Name	Connector (Pin No.)	Setting Function	Control Function No.
Input 1	CN17 (1-2)	Fixed Heating Operation Mode	1
Input 2	CN17 (2-3)	Fixed Cooling Operation Mode	2
Input 3 (*)	CN18 (1-2)	Demand Stoppage	3

<Output Terminal>

Output Terminal Name	Connector (Pin No.)	Setting Function	Control Function No.
Output 1	CN16 (1-2)	Operation Signal	1
Output 2	CN16 (1-3)	Alarm Signal	2

- Setting of External Input and Output

In the case that the setting alteration is required at site, perform the following procedures.

For the combination of outdoor units, perform the setting to the outdoor unit A.

- By selecting “External Input and Output Setting”, the following appears on the 7-segment display.
(The setting should be performed during the outdoor unit stoppage.)

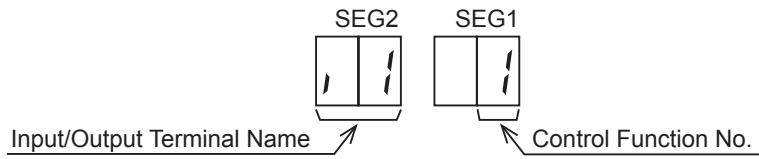

This display indicates that the control function No. 1 (Fixed Heating Operation Mode) is set at input 1.

- By pressing PSW2 or PSW4, input/output terminal name is changed.
The following shows the display changes when PSW2 or PSW4 are pushed.

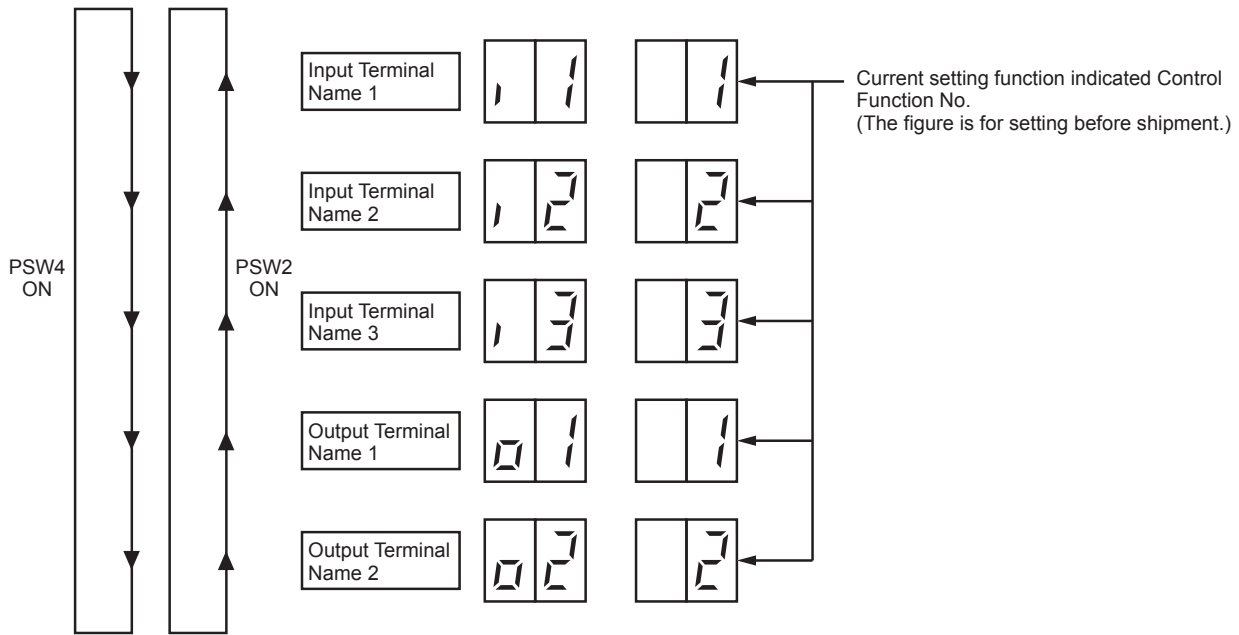

- After selecting Input/Output Terminal Name, press PSW3 or PSW5, and then choose Control Function No.

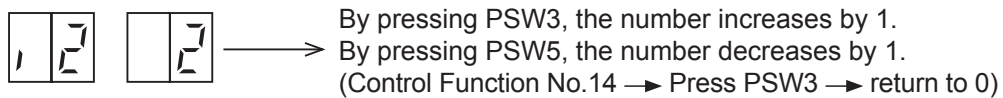

- After selecting the control function No., press PSW1 for 3 seconds. The display will be back to the normal indication. The selected contents are memorized in the outdoor unit PCB and “External Input and Output Setting” is completed. The memorized data are maintained even when power source is cut OFF. Refer to the table 4.1 for the notes for the electrical wiring connection and the required parts.

- External Input Function Setting

The following signals can be received by the outdoor unit PCB. Refer to the table 4.1 for the required main parts.

4.2.1 **Input** Fixing Heating Operation Mode (Control Function No.1),
Input Fixing Cooling Operation Mode (Control Function No.2)

When the input terminals for fixing operation mode on the outdoor unit PCB are short-circuited, the operation mode can be fixed at the cooling or heating mode

Short Circuit between Terminals 1 and 2 of CN17: Fixed Heating Operation Mode

Short Circuit between Terminals 2 and 3 of CN17: Fixed Cooling Operation Mode

During this fixed heating (or cooling) mode, no cooling (or heating) operation is available. The indoor units under the cooling or dry operation (or heating operation) will be changed to the Thermo-OFF condition during this mode, and stoppage code No. "20" is given.

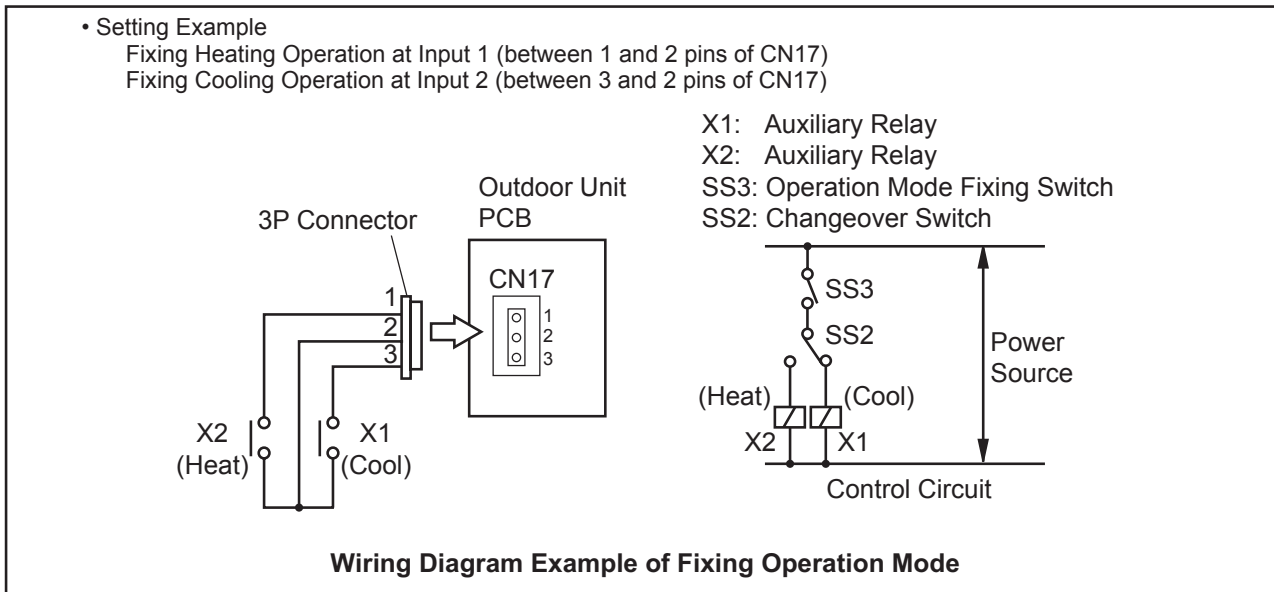

4.2.2 **Input** Demand Stoppage (Control Function No.3)

When the input terminals for demand stoppage on the outdoor unit PCB are short-circuited, compressor(s) is stopped. (In this case, the indoor unit(s) is put under Thermo-OFF condition. Cooling operation: Air-flow setting, Heating operation: Lo setting)

The stoppage code No. "10" is given. By disconnecting the demand switch contact, restarting is available.

NOTE:

When demand control (ON/OFF) is performed, it is recommended that the control (ON/OFF) time is set as appropriate according to the heat load. Also, set the demand control time approximately once in 30 minutes at the minimum in consideration of energy saving.

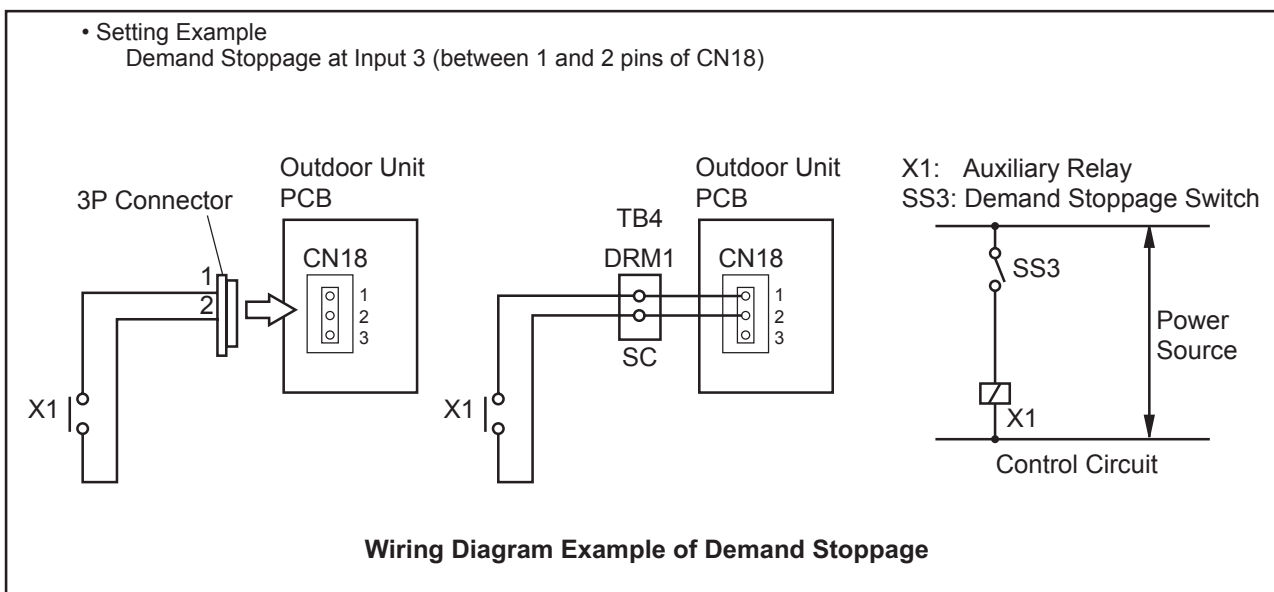

4.2.3 **Input** Outdoor Fan Motor Start/Stop (Control Function No.4)

This is an auxiliary function to protect the outdoor unit from snow. When the input terminals for Outdoor Fan Motor Start/Stop on the outdoor unit PCB are short-circuited during the compressor stoppage, all the outdoor fan motors start operating. If the compressor restarts operating, the outdoor fan motors will be restored to normal operation. If the input terminals of Outdoor Fan Motor Start/Stop are opened during the outdoor fan motor operation following the short circuit of these terminals, the outdoor fan motor will stop.

This function is available only during the compressor stoppage (during the compressor power-OFF or thermo-OFF of the compressor power-ON) and the ambient temperature must be greater than or equal to 10 C .

Therefore, this function will not be available even if the input signal is sent during the normal cooling or heating operation. An example of basic wiring when Outdoor Fan Motor Start/Stop (Input 2) is set to 2 and 3 pins of CN17 by an external signal is shown below.

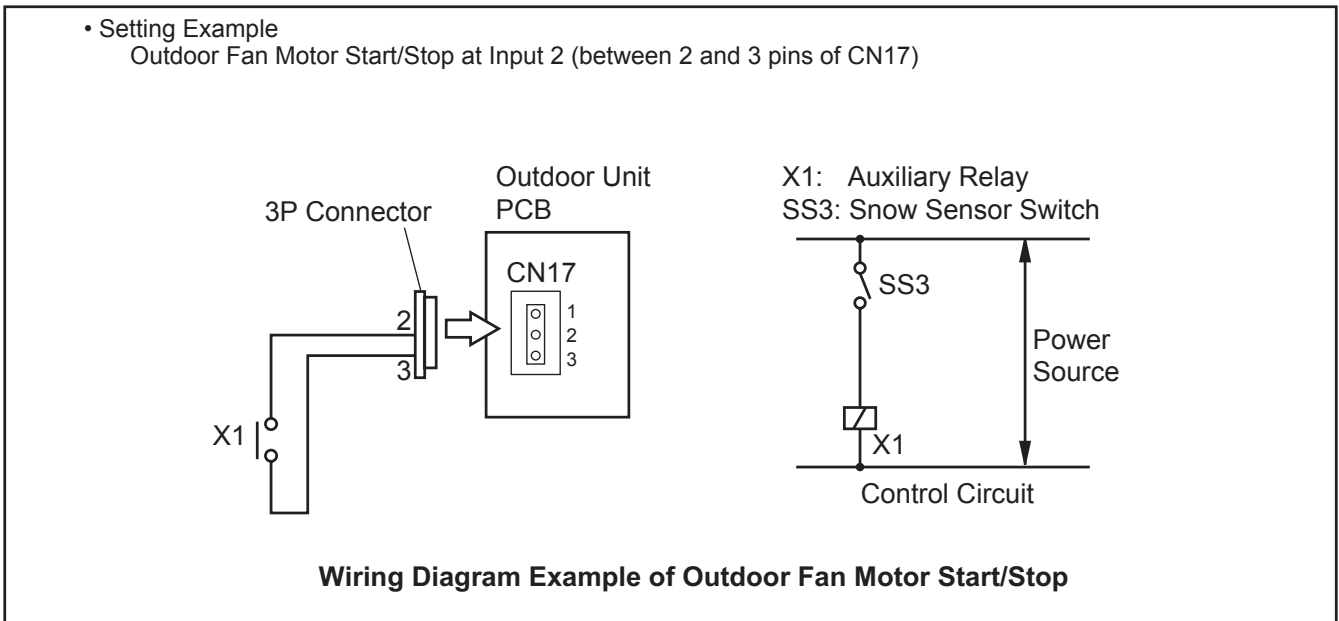

NOTE:

- This is an auxiliary function to protect the unit from snow. In snowy regions, make sure to protect the unit with a snow-prevention roof, fence or snow-prevention hood (Field-Supplied), etc.. Otherwise, abnormal vibrations due to imbalanced propeller fan will be caused.
- If the fan motor or fan controller fail during the outdoor fan motor start/stop operation, stop all the outdoor fan motor to suspend the operation. Check the alarm code and deal properly with the failure next time the compressor is operated.
- When setting the snow sensor switch for Outdoor Fan Motor Start/Stop, make sure that the continuous operating time is 30 seconds or more. Also the outdoor fan motor start/stop intervals shall be at least 10 minutes. Otherwise, malfunction of the outdoor fan motors will be caused by frequent start/stop.

! WARNING

Because of this setting, the outdoor fan can operate even while the outdoor unit (compressor) stops. Display a notice to that effect on a readily visible part of the unit body, in order to avoid injuries caused by an unintended outdoor fan operation.

4.2.4 **Input** Forced Stoppage (Control Function No.5)

When the input terminals for the forced stoppage on the outdoor unit PCB are short-circuited during running, the compressor and the indoor fan motor are stopped. However, the remote control switch display remains the same mode as the stoppage code No. "10".

In this case, if the input terminals are opened, operation is resumed.

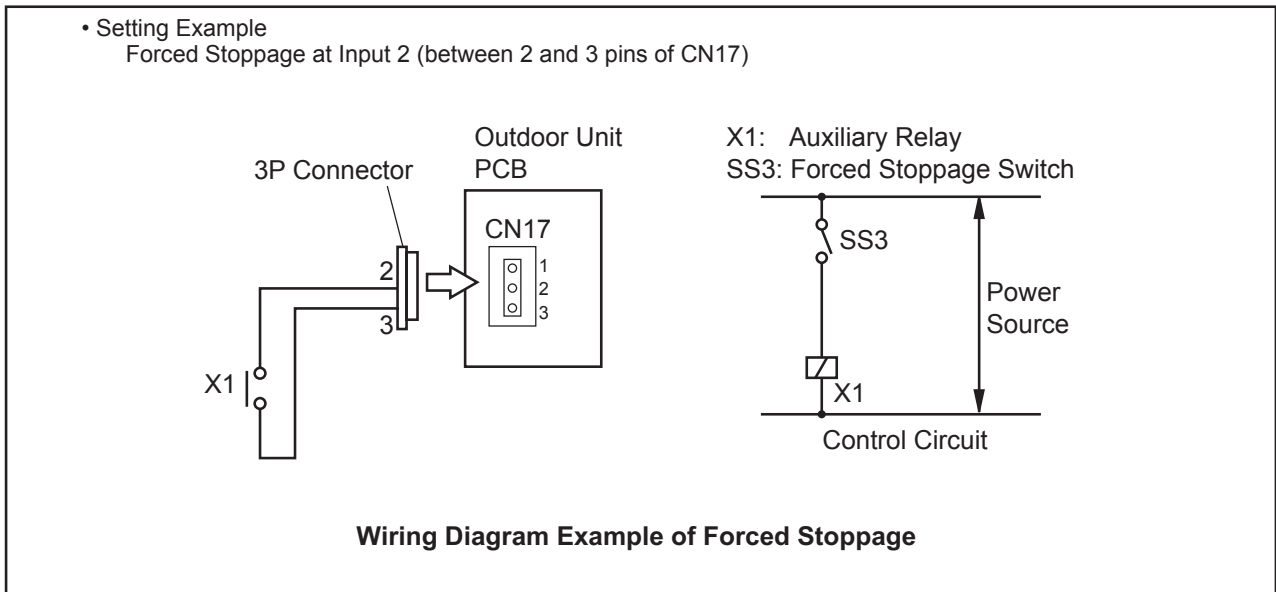

4.2.5 **Input** Demand Current Control 40, 60, 70, 80, 100% (Control Function No.6 to 10)

When the input terminals for demand current control on the outdoor unit PCB are short-circuited, the compressor frequency is controlled so that the maximum limit of the outdoor running current is set to 100%, 80%, 70%, 60% and 40%.

(The maximum limit of the outdoor unit running current can be selected according to the item "4.2 External Input and Output Setting".)

If the outdoor unit running current exceeds the maximum limit, the indoor unit is put under thermo-OFF condition. The stoppage code No. "10" is given. When the input terminal is opened during the demand current control, its control is reset.

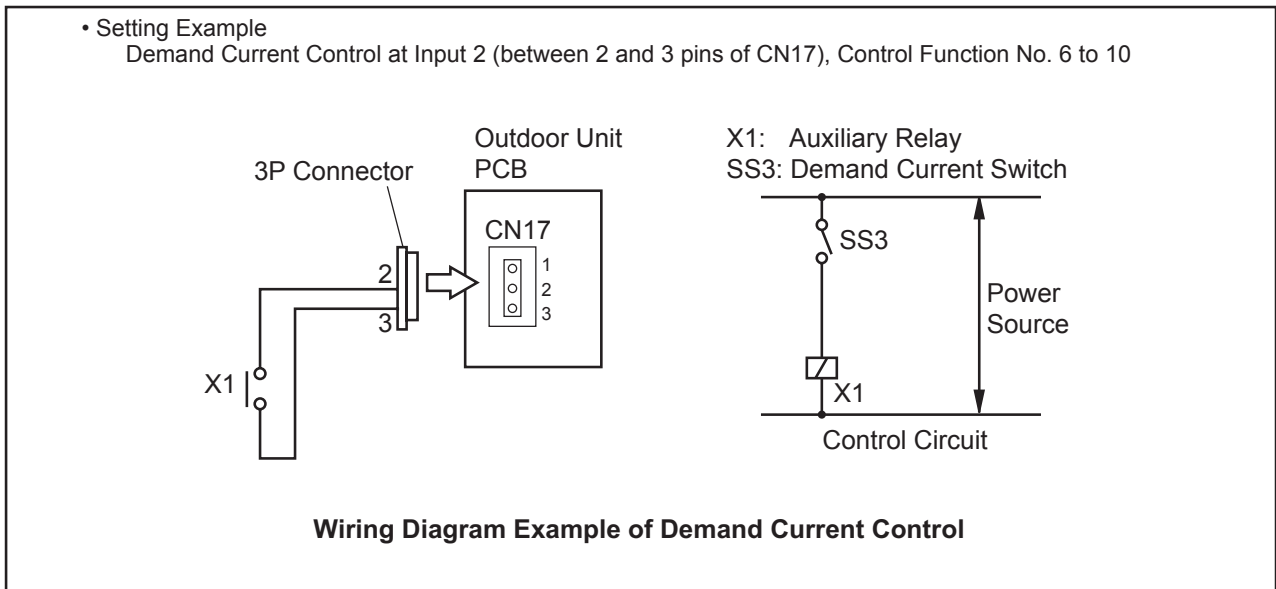

< NOTES at Facility Design >

- The demand current control (%) is value criterion. The value used for this control is calculated from the current, and therefore is different from the value indicated by a wattmeter. If it is required that the maximum power consumption is managed precisely, a field-supplied demand controller should be used
- The actual value may temporarily be higher than the indicated value (by 40 ~100%) depending on the operating control conditions such as protection control.

4.2.6 **Input** Low Noise Setting 1,2, 3 (Control Function No.11 to 13)

When the input terminals for low noise setting on the outdoor unit PCB are short-circuited, the compressor frequency and outdoor fan rotation frequency are controlled and the operating sound of the outdoor unit will be given as shown in the table below.

The operating sound can be set by selecting the control function No.

NOTE:

- (a) The outdoor unit capacity will decrease because the compressor frequency and outdoor fan motor frequency forcibly decrease. The operating range will be also restricted.
- (b) In some cases, the operating sound may be temporarily higher than the value in the table below (targeted value).

< Control Function No. for Low Noise Setting and Operating Sound/Outdoor Unit Capacity >

Control Function No.	Operating Sound (Targeted Value)
No Setting	Catalog Value
11 (Low Noise Setting 1)	Refer to 4.3.5 Low Noise Setting (dB=7)
12 (Low Noise Setting 2)	Refer to 4.3.5 Low Noise Setting (dB=8)
13 (Low Noise Setting 3)	Refer to 4.3.5 Low Noise Setting (dB=9)

• Setting Example

Low Noise Setting at Input 2 (between 2 and 3 pins of CN17), Control Function No. 12

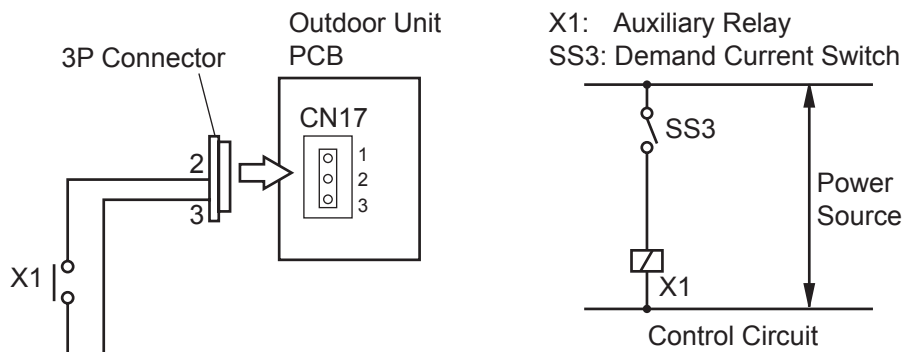

Wiring Diagram Example of Low Noise Setting

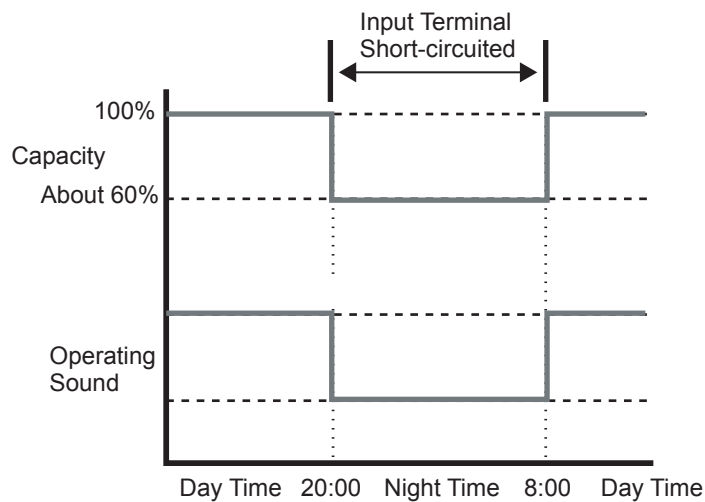

[Example] “Low Noise Setting 2” during Night Time Only

Table 4.1 Specifications of Required Main Part

Parts		Specification	Remarks
Auxiliary Relay (X1, X2)		Mini-Power Relay, MY1F (or 2F) made by OMRON	220V/240V
Changeover Switch (SS2, SS3)		Manual Switch	220V/240V
3 Pin Connector Cord		PCC-1A (Connected to JST Connector, XARP-3)	Five Cords with Connectors as One Set
Electric Wire (Inside of Unit)	Low Volt.	0.3mm ²	lower than 24V
	220/240V	0.5 to 0.75mm ²	
Electric Wire (Outside of Unit)	Low Volt.	0.5 to 0.75mm ²	lower than 24V
	220/240V	2mm ²	

NOTE:

- Make the wire to the terminals as short as possible.
- Do not run the wires along high voltage cable. Keep at least 30cm between the wire and the high voltage cable. (Crossing is applicable.)

If it is necessary to run the wires along the high voltage cable, insert the low voltage cable(s) into metal tube and ground it at one end. If sealed wires are used at the low voltage wire side, ground it at one end of the shield wires. The maximum length should be within 70m.

- External Output Function Setting

The following signals can be picked up from the outdoor unit PCB.

Refer to the table 4.2 for the required main parts.

4.2.7 Output Operation Signal (Control Function No.1)

This function is utilized to receive the operation signal.

Auxiliary relay contacting (RYa) is closed during the operation. Operation signal will be sent to output terminals when the indoor units are operating. (Even when one (1) indoor unit is operating, the signal will be sent.) This function can be used for circulator or humidifier operation.

- Setting Example

Operation Signal at Output 1 (between 1 and 2 pins of CN16)

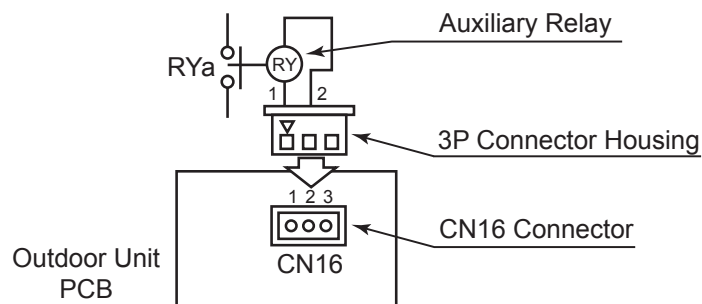

Wiring Diagram Example of Operation Signal

4.2.8 Output Alarm Signal (Control Function No.2)

This function is utilized to receive the alarm signal.

Auxiliary relay contacting (RYa) is closed when the alarm occurs. Alarm signal will be sent to output terminals when the alarm occurs from the indoor units. (The signal will be sent even when the alarm occurs from one (1) indoor unit.)

- Setting Example

Alarm Signal at Output 2 (between 1 and 3 pins of CN16)

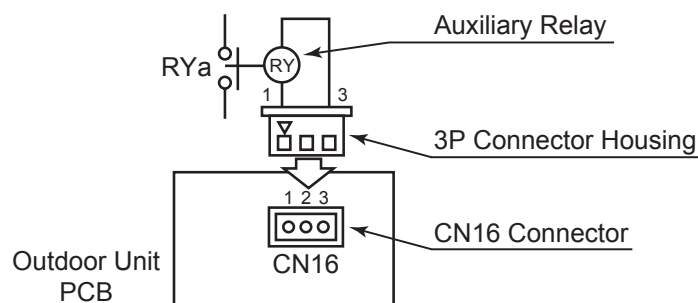

Wiring Diagram Example of Alarm Signal

4.2.9 **Output** Compressor ON Signal (Control Function No.3)

This function is utilized to receive the compressor operation signal.
 Auxiliary relay contacting (RYa) is closed during the compressor operation.

- Setting Example
 Compressor ON Signal at Output 2 (between 1 and 3 pins of CN16)

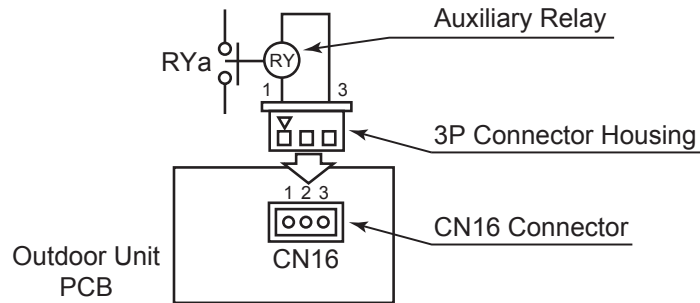

Wiring Diagram Example of Compressor ON Signal

4.2.10 **Output** Defrosting Signal (Control Function No.4)

This function is utilized to receive the defrosting signal.
 Auxiliary relay contacting (RYa) is closed during the defrosting.

- Setting Example
 Defrosting Stoppage at Output 2 (between 1 and 3 pins of CN16)

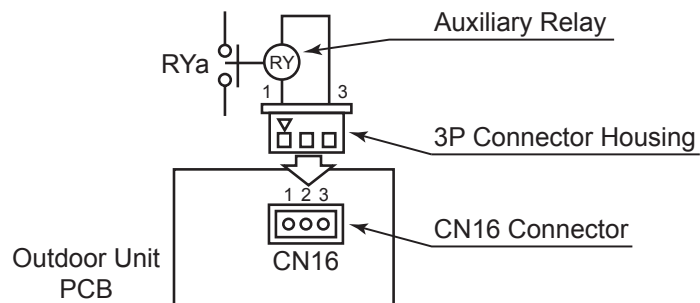

Wiring Diagram Example of Defrosting Signal

Table 4.2 Specifications of Required Main Part

Parts	Specification
Auxiliary Relay *	High-Power Relay, LY2F DC12V made by OMRON

* Do not use the relay with diode built-in.

* Refer to the table 4.1 for the connector parts.

4.3 Function Setting

- (1) The setting should be performed during the outdoor unit stoppage.
For the combination of outdoor units, set it to the outdoor unit A. (The setting can not be performed to the outdoor unit B, C and D.) The outdoor unit A is the unit to which the control cable between outdoor unit and indoor unit is connected.

- (2) Press PSW1 for more than 3 seconds.
“Menu” will display on the 7-segment display. The menu indication is changed by pressing PSW2 or PSW4 and displayed in the following order.

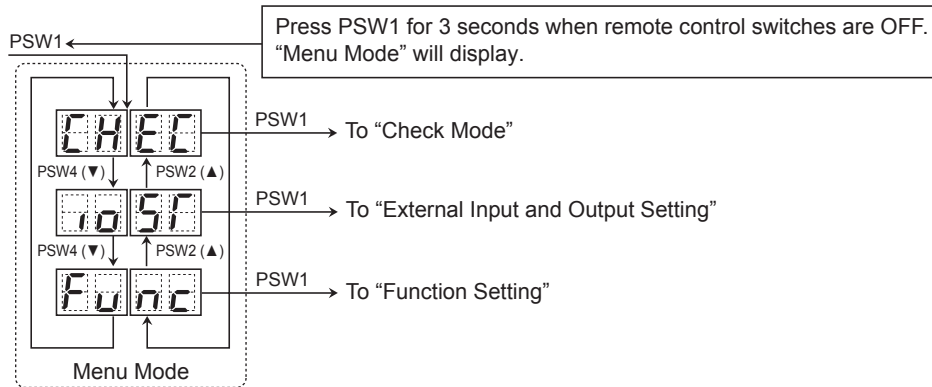

Select the function setting mode indicated as "Func" on the 7-segment display.

Arrangement of Push Switches on Outdoor Unit PCB

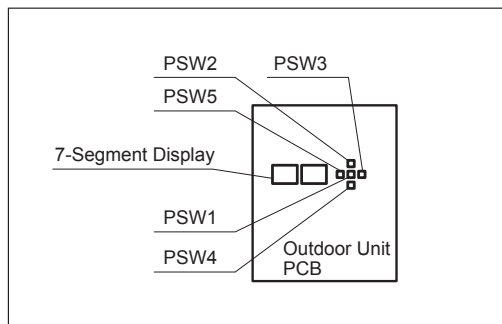

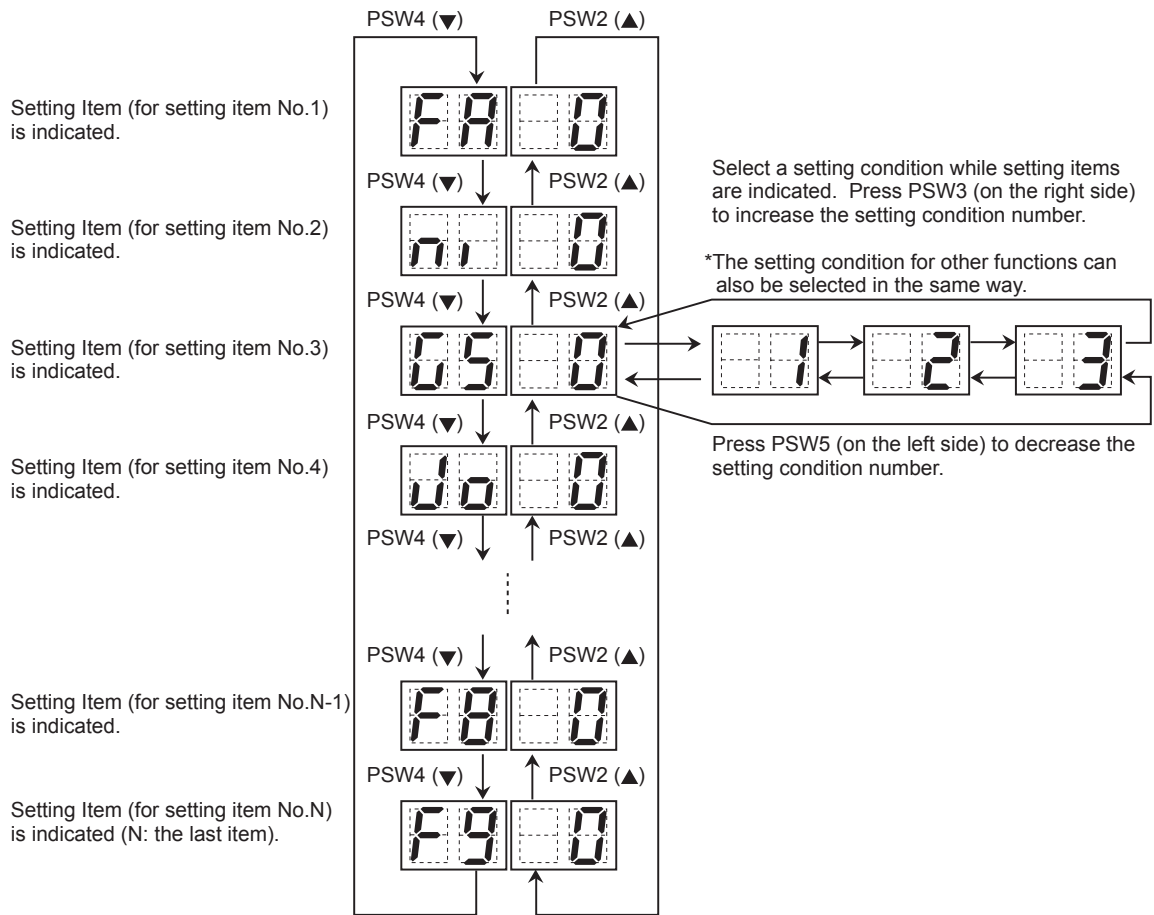

- (3) After selecting the control function No., press PSW1 for 3 seconds. The display will be back to the normal indication. The selected contents are memorized in the outdoor unit PCB and "Function Setting" is completed. The memorized data are maintained even when power source is cut OFF.

4.3.1 Circulator Function at Heating Thermo-OFF (Control Function FA)

Press “PSW3” and select the setting conditions “0 to 4” in the circulator function at heating Thermo-OFF “FA”.

Normally, the fan speed is changed to “LOW” at heating Thermo-OFF. (There is a case that the room temperature is too high at the heating Thermo-OFF.) However, the indoor fan motor is operated at “LOW” and stopped repeatedly by setting this function.

NOTE:

When the compressor is stopped, the indoor fan motor operates at “LOW” speed continuously.
The action when the indoor fan motor operates at the circulator function is indicated as follows.

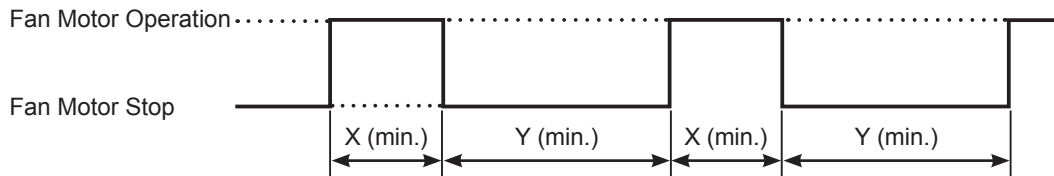

Contents of Function Setting Item "FA"

	Contents of Function Setting Item "FA"				
	0	1	2	3	4
Indoor Fan Motor "LOW" Operation Time X (min.)	(Continuous Operation)	2	2	2	0
Indoor Fan Motor Stop Time Y (min.)	0	6	13	28	Stopped

NOTE:

In case of using the function setting No.2 to 4, install the remote sensor. Because the time period of stopping the indoor fan becomes longer, the detected value of the suction air thermistor for indoor unit becomes high, and it may take time to Thermo-ON.

4.3.2 Night-Shift (Low Noise)

Press “PSW3” and select the setting condition “1” at the night shift (low noise) “ n_1 ”. Then, this function can be set. This setting is available when the ambient temperature is 30°C or less at the cooling operation.

The outdoor fan operation is controlled by fan controller as shown below.

The night shift operation shall be applied in case that the cooling capacity has the margin to be allowed for the capacity decrease and the low sound operation is required especially in the night time.

(1) Outdoor Fan

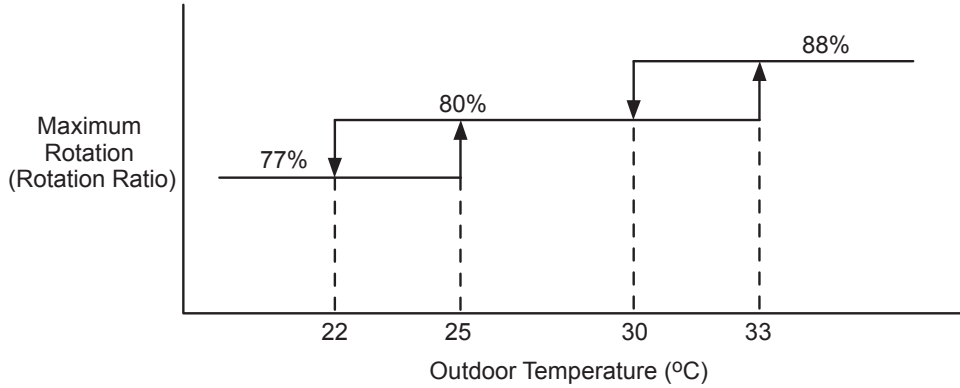

(2) Frequency Range (Cooling Operation)

[AVWT-***HKFXE]

	Outdoor Unit Capacity (kBtu/h)	Maximum Frequency (Hz)	Conditions		Outdoor Unit Capacity (kBtu/h)	Maximum Frequency (Hz)	Conditions
When Night Shift is Set $n_i=0$	76	74	Except for the Conditions on the Right	When Night Shift is Set $n_i=1$	76	56	-
	96	76			96	63	
	114	90			114	70	
	136	117			136	83	
	154	117			154	83	
	170	117			170	93	
	190	153			190	120	
	212	180			212	140	
	232	180			232	150	
	250	234			250	165	
272	234	272	180				

NOTE:

For the combination of outdoor units, the frequency for each outdoor unit becomes less than the value above.

4.3.3 Cancellation of Outdoor Ambient Temperature Limit

Press "PSW3" and select the setting condition "0" to "3" at the cancellation of outdoor ambient temperature limit of "U₁U₂". Then, this function can be set.

The cooling operation is continued even under a low temperature.

Setting Condition	Operation Mode for Cancellation
0	Not Available (Default Setting)
1	Heating(only for heat pump system)
2	Cooling
3	Heating/Cooling

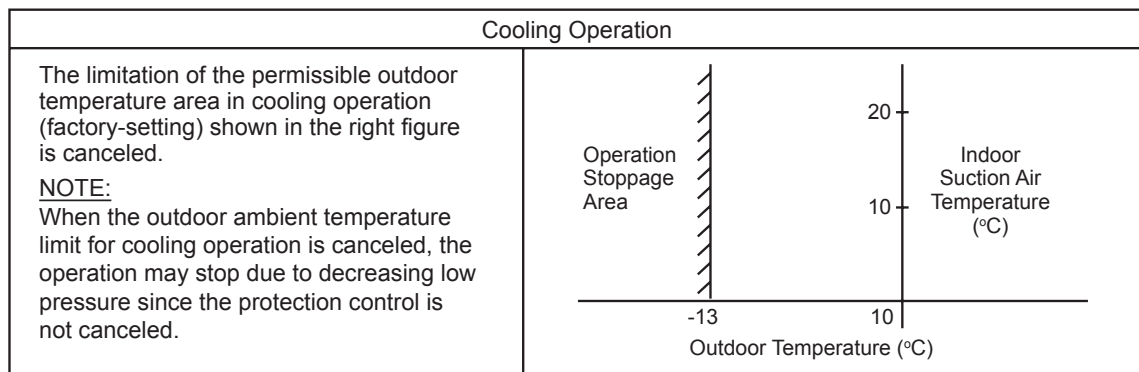
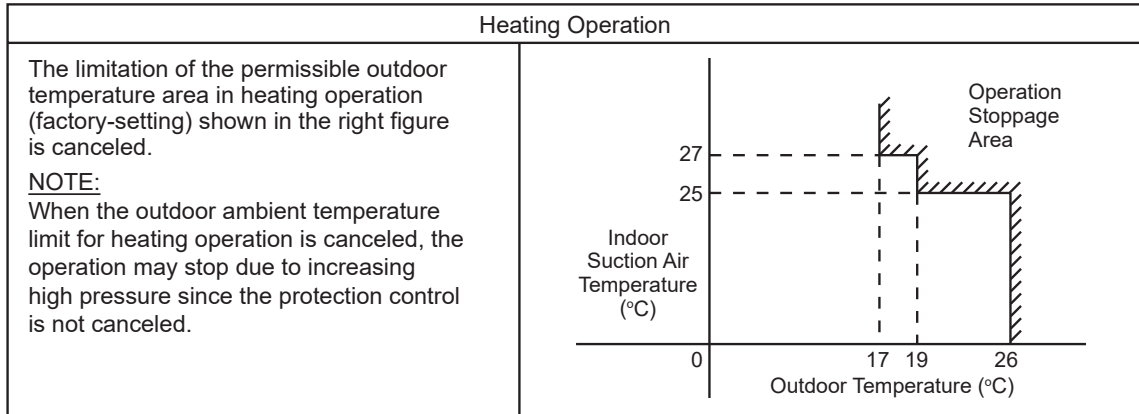

NOTE:

If this function is set and the outdoor unit operates in the operation stoppage area shown in the above figure for a long time, the outdoor unit may be damaged since protection control is canceled.

4.3.4 Defrost for Cold Area (Change of Defrost Condition)

Press "PSW3" and select the setting condition "1" at the defrost for cold area "U₁U₂".

Setting Condition	Standard Specifications	Cold Area Specifications
	When Change of Defrost Condition is NOT Set	When Change of Defrost Condition is Set
Temperature Conditions under Defrosting Operation		

4.3.5 SLo (Fan Speed) Defrost Setting

Press "PSW3" and select the setting condition "0" to "3" at the SLo defrost setting "61".

Indoor fan operation is stopped during the defrost operation and at the start of the heating operation. However, this function can operate the indoor fan at low speed during the defrosting operation and at the start of the heating operation.

Setting Condition	Indoor Fan Operation
0	Not Available (Default Setting)
1	Indoor fan SLo when heating operation is activated/during defrost operation
2	-
3	-

4.3.6 Priority Capacity Mode Setting

If the unit capacity seems insufficient during the normal operation, press "PSW3" and select the setting condition "0" to "3" Capacity-Focused Mode Setting "71". By setting this function, the target frequency, current limit of the compressor, the fan-speed maximum limit value and discharge pressure limit value are set higher.

NOTE:

Do not use the setting condition "2" and "3" unless the power source line is of sufficient ampacity, because the target frequency and current limit of the compressor during the operation are set higher.

Setting Condition	Compressor Frequency and Current Operation
0	Not Available (Default Setting)
1	Frequency maximum limit value is set higher.
2	Frequency maximum limit value and current limit value are set higher.
3	Frequency maximum limit value, current limit value and the fan-speed maximum limit value are set higher.
4	Maximum discharge pressure limit value is set higher.

4.3.7 Low Noise Setting

Press "PSW3" and select the setting condition "0" to "9" at the Low Noise Setting "81" to reduce the compressor frequency and the outdoor fan motor rotation frequency.

The operating noise (targeted value) can be set by selecting the setting condition shown below.

NOTE:

- By setting this function, the compressor frequency and the outdoor fan motor rotation frequency are forcibly reduced and so the outdoor unit capacity decreases and the unit operation range is limited.
- The operating noise values for a single unit are shown below. These are targeted values and so the actual values can temporarily be higher depending on operation conditions. The operating noise values for combination units are higher than the values below.

Setting Condition	Compressor Frequency Limit	Outdoor Fan Motor Step Limit
0	Not Changed	Not Changed
1	Not Changed	20 Steps
2	Not Changed	18 Steps
3	Not Changed	16 Steps
4	Low	Not Changed
5	Lower	Not Changed
6	Lowest	Not Changed
7	Low	20 Steps
8	Lower	18 Steps
9	Lowest	16 Steps

Outdoor Unit Capacity(kBtu/h)	db=9		db=8		db=7	
	Operating Noise (Targeted Value (dB))	Capacity (Compared to db=0)	Operating Noise (Targeted Value (dB))	Capacity (Compared to db=0)	Operating Noise (Targeted Value (dB))	Capacity (Compared to db=0)
76	45	67%	46	74%	47	82%
96	44	60%	45	74%	46	81%
114	46	66%	49	75%	51	84%
136	48	67%	49	74%	51	86%
154	48	63%	50	71%	53	81%
170	50	61%	52	70%	52	83%
190	52	63%	54	75%	57	83%
212	53	64%	55	75%	60	85%
232	52	60%	56	76%	60	86%
250	53	60%	58	71%	61	80%
272	53	62%	58	72%	61	80%

4.3.8 Demand Function Setting

Press "PSW3" and select the setting condition "0" to "5", so that the demand function setting "d₁L" can be set. This function is available by setting to "1" for the demand current control without inputting the signal to the external input terminal on the outdoor unit PCB. The table below is shown for the limit of the operating current for this function.

NOTE:

In the case that the demand current control by external input is set and the external input signal is available, this function is not available even when the demand current control by external input signal is performed.

Setting Condition	Demand Running Current Control
0	Not Available (Default Setting)
1	40%
2	60%
3	70%
4	80%
5	100%

- Demand Control
Adopting self-demand function, which drastically decreases power consumption, has largely improved energy saving.

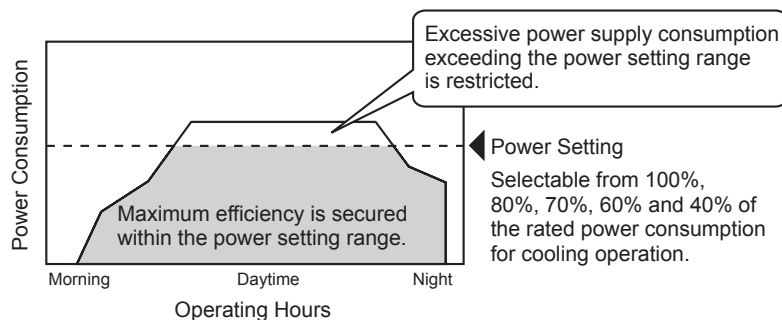

< NOTES at Facility Design >

1. The demand current control (%) is value criterion. The value used for this control is calculated from the current, and therefore is different from the value indicated by a wattmeter. If it is required that the maximum power consumption is managed precisely, a field-supplied demand controller should be used.
2. The actual value may temporarily be higher than the indicated value shown above depending on the operating control conditions such as protection control.

4.3.9 Wave Function Setting

Press “PSW3” and select the setting condition “0” to “4”, so that the wave function setting “ F_{WF} ” can be set.

While this function is activated, the maximum limit of running current is changed from 40% to 80% as shown in the figure.

NOTE:

In the case that the demand current control by external input is set and the external input signal is available, this function is not available even when the demand current control by external input signal is performed.

Setting Condition	Running Current Lower Limit Setting
0	Not Available (Default Setting)
1	40%
2	60%
3	70%
4	80%

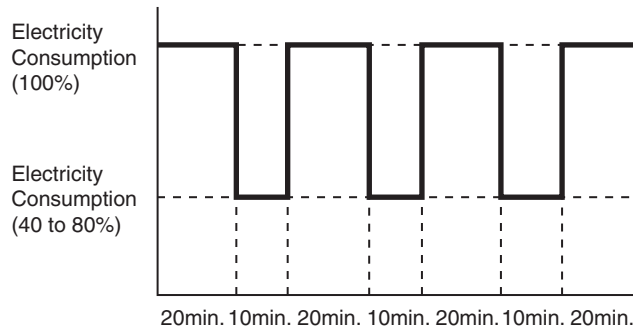

NOTE:

The current limit value is targeted value. The actual current value may temporarily be higher than the value shown in the table above depending on the operating control condition.

When the scheduled operation of “Demand Function Setting” is set from the centralized controller, refer to “Technical Catalog” and “Installation & Maintenance Manual” of the centralized controller. For this function, the central station is applicable.

4.3.10 Cold Draft Protection

Press “PSW3” and select the setting condition “0” to “3” at the cold draft protection “ F_{CD} ”, so the cold draft protection can be set. When the indoor unit discharge air temperature falls down at cooling operation, outdoor fan stops and compressor frequency forcibly decreases to prevent a drop in discharge air temperature. If the outlet temperature decreases and the temperature is less than Thermo-OFF condition even after the compressor frequency decreases, the indoor unit becomes Thermo-OFF condition.

(When Thermo-OFF is activated under this condition, the operation will be restarted after 3 minutes.)

Setting Condition	Outlet Temperature	
	Target Value	at Thermo-OFF
0	-	-
1	10°C	7°C
2	12°C	9°C
3	14°C	11°C

4.3.11 Adjustment of Fan Rotation

Press “PSW3” and select the setting condition “0” to “2” at the fan rotation adjustment “ F_{FR} ”, so the fan rotation adjustment can be set. If the outdoor unit fans make a whining sound in the case of the multiple installation, set this function to the relevant outdoor units.

Setting Condition	Adjustment of Fan Rotation
0	Not Available (Default Setting)
1	-15 rpm
2	-30 rpm

4.3.12 Intermittent Operation of Outdoor Fan Motor

Press “PSW3” and set the Outdoor Fan Motor Intermittent Operation Setting “F 4” (auxiliary function) to protect the outdoor fan motor from snow. Set this function to the PCB of the outdoor unit set as the main outdoor unit. All the outdoor fan motors start intermitted operation($t1/600s$). This function is available only during the input control function No.4 is valid.If the compressor restarts operating, the outdoor fan motors will be restored to normal operation.

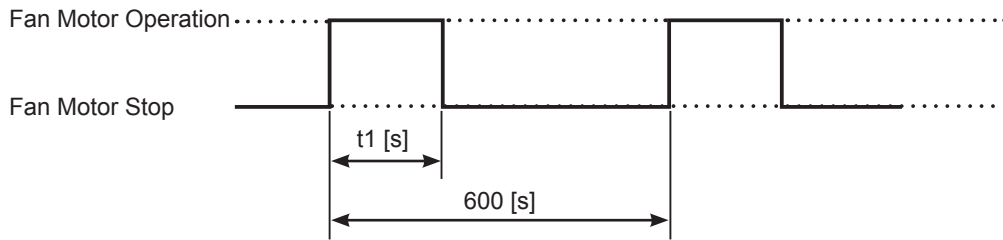

Setting Condition	Operating time of outdoor fan $t1(s)$
0	0 Continuous operation(600s)
1	30
2	60
3	120
4	300

NOTE:

1. This is an auxiliary function to protect the unit from snow. In snowy regions, make sure to protect the unit with a snow-prevention roof, fence or snow-prevention hood (Field-Supplied), etc.. Otherwise, abnormal vibrations due to imbalanced propeller fan will be caused.
2. If the fan motor or fan controller fail during the outdoor fan motor start/stop operation, stop all the outdoor fan motor to suspend the operation. Check the alarm code and deal properly with the failure next time the compressor is operated.

! WARNING

Because of this setting, the outdoor fan can operate even while the outdoor unit (compressor) stops. Display a notice to that effect on a readily visible part of the unit body, in order to avoid injuries caused by an unintended outdoor fan operation.

4.3.13 Function Setting

No.	Setting Item	7-Segment Display		Contents
		SEG2	SEG1	
1	Circulator Function at Heating Thermo-OFF	FA	00	Not Available (Default Setting)
			01	Indoor fan forced ON and OFF (2 min. ON / 6 min. OFF)
			02	Indoor fan forced ON and OFF (2 min. ON / 13 min. OFF)
			03	Indoor fan forced ON and OFF (2 min. ON / 28 min. OFF)
			04	Indoor fan forced OFF
2	Night-Shift Mode	ni	00	Not Available (Default Setting)
			01	Setting of Night Mode
3	Cancellation of outdoor ambient temperature limit	GS	00	Not Available (Default Setting)
			01	For heating
			02	For cooling
			03	For cooling/heating
4	Defrost for cold area (change of defrost condition)	Jo	00	Not Available (Default Setting)
			01	Condition 2 of defrost operation for cold area.
5	SLo (Fan Speed) defrost setting	bj	00	Not Available (Default Setting)
			01	Indoor fan SLo when heating operation is activated/during defrost operation
			02	-
			03	-
6	Cancellation of hot start	HT	00	Hot start control is available
			01	Cancellation of hot start
			02	Increase the time of hot start control
7	Priority Capacity Mode	nU	00	Not Available (Default Setting)
			01	Change of frequency maximum limit value
			02	Change of frequency maximum limit value and current limit value
			03	Change of frequency maximum limit value, current limit value and the fan-speed maximum limit value
			04	Change of maximum discharge pressure limit value
8	Compressor frequency control target value for cooling	Hc	00	Initial setting (P's evaporation temperature target value 7℃)
			01	Target value (2℃)
			02	Target value (3℃)
			03	Target value (4℃)
			04	Target value (5℃)
			05	Target value (9℃)
			06	Target value (10℃)
			07	Target value (11℃)
9	Compressor frequency control target value for heating	Hh	00	Default Setting
			01	Target value (2.60MPa)
			02	Target value (2.75MPa)
			03	Target value (2.80MPa)
			04	Target value (2.82MPa)
			05	Target value (2.88MPa)
			06	Target value (2.90MPa)
			07	Target value (2.95MPa)
10	Indoor expansion valve control target value for cooling	SC	00	Default Setting
			01	SH Target value +2
			02	SH Target value +1
			03	SH Target value -1
			04	SH Target value -2
11	Indoor expansion valve control target value for heating	SH	00	Default Setting
			01	SC Target value +6
			02	SC Target value +3
			03	SC Target value -3
			04	SC Target value -6
12	Indoor Expansion Valve Opening Change for Stoppage Indoor Unit in Heating Mode	Si	00	Default Setting(Reference control parameters)
			01	Expansion valve opening 150~325 pulse
			02	Expansion valve opening 05~19kBtu/h: 170 pulse, 22kBtu/h or over: 300 pulse
			03	Expansion valve opening 05~19kBtu/hHP: 100 pulse, 22kBtu/h or over: 150 pulse
			04	Expansion valve opening 05~19kBtu/hHP: 90 pulse, 22kBtu/h or over: 100 pulse
			05	Expansion valve opening 05~19kBtu/hHP: 40 pulse, 22kBtu/h or over: 40 pulse
13	Indoor Expansion Valve Opening Change for Thermo-OFF Indoor Unit in Heating Mode	So	00	Initial setting (refere to control parameters)
			01	Expansion valve opening 05~19kBtu/h: 170 pulse, 22kBtu/h or over: 300 pulse
			02	Expansion valve opening 05~19kBtu/h: 100 pulse, 22kBtu/h or over: 150 pulse
			03	Expansion valve opening 05~19kBtu/h: 40 pulse, 22kBtu/h or over: 40 pulse
14	Indoor Expansion Valve Initial Opening of Thermo-ON Indoor Unit in Heating Mode	ci	00	Initial setting(refere to control parameters)
			01	Expansion valve opening 300~650
			02	Expansion valve opening 05~19kBtu/h: 650 pulse, 22kBtu/h or over: 1000 pulse
			03	Expansion valve opening 05~19kBtu/h: 950 pulse, 22kBtu/h or over: 1500 pulse
			04	Expansion valve opening 05~19kBtu/h: 1440 pulse, 22kBtu/h or over: 2000 pulse

No.	Setting Item	7-Segment Display		Contents
		SEG2	SEG1	
15	Fine Adjustment of Indoor Expansion Valve Initial Opening in Cooling Mode	cb	00	Initial setting□1.00□
			01	Operation initial opening*0.95
			02	Operation initial opening *1.03
			03	Operation initial opening *1.05
			04	Operation initial opening *1.10
16	Fine Adjustment of Indoor Expansion Valve Initial Opening in Heating Mode	ch	00	Initial setting□1.00□
			01	Operation initial opening*0.95
			02	Operation initial opening *1.03
			03	Operation initial opening *1.05
			04	Operation initial opening *1.10
17	Low noise setting (In the case of low noise setting, cooling/heating operation range will be restricted.)	db	00	Initial setting
			01	Fan rotation maximum - low
			02	Fan rotation maximum - lower
			03	Fan rotation maximum - lowest
			04	Frequency of compressor - low
			05	Frequency of compressor - lower
			06	Frequency of compressor - lowest
			07	Frequency of compressor - low, Fan rotation maximum - low
			08	Fan rotation maximum - lower, Frequency of compressor - lower
			09	Fan rotation maximum - lowest, Frequency of compressor - lowest
			10	-
18	Demand function setting	dE	00	No demand control
			01	Demand control 40%
			02	Demand control 60%
			03	Demand control 70%
			04	Demand control 80%
			05	Demand control 100%
19	Wave function setting	UE	00	No wave function
			01	Minimum limit 40%
			02	Minimum limit 60%
			03	Minimum limit 70%
			04	Minimum limit 80%
20	Cold Draft Protection	Fb	00	Initial setting
			01	Outlet temperature ≥10□
			02	Outlet temperature ≥12□
			03	Outlet temperature ≥14□
21	Connection Setting of Fresh Air Unit or AHU	FT	00	Initial setting
			01	Inhibition ability model
			02	Compressor Frequency control by indoor unit.
22	Adjustment of Fan Rotation (for multiple installation.)	Fo	00	Initial setting
			01	Change of fan rotation -15rpm
			02	Change of fan rotation -30rpm
23	Height Difference Setting	Hd	00	Initial setting
			01	The height difference is 60m
			02	The height difference is 70m
			03	The height difference is 80m
			04	The height difference is 90m
			05	The height difference is 100m
24	Initial opening of indoor expansion valve at heating operation stoppage	F1	00	Initial setting (refere to control parameters)
			01	Expansion valve opening 150~325
			02	Expansion valve opening 05~19kBtu/h: 175 pulse, 22kBtu/h or over: 300 pulse
			03	Expansion valve opening 05~19kBtu/h: 100 pulse, 22kBtu/h or over: 150 pulse
			04	Expansion valve opening 05~19kBtu/h: 90 pulse, 22kBtu/h or over: 100 pulse
			05	Expansion valve opening 05~19kBtu/h: 40 pulse, 22kBtu/h or over: 40 pulse
25	Automatic Night-Shift	nb	00	Initial setting
			01	Take effect at 8 hours and then exit after 8 hours
			02	Take effect at 8 hours and then exit after 9 hours
			03	Take effect at 8 hours and then exit after 10 hours
26	Intermittent Operation of Outdoor Fan Motor	F4	00	Continuous operation 600s
			01	intermittent operation 30s/600s
			02	intermittent operation 60s/600s
			03	intermittent operation 120s/600s
			04	intermittent operation 300s/600s
27 ~ 31	Address Setting for VIP Indoor Unit	u1 ~ u5	0	Indoor unit address 00
			~	Indoor unit address **
			63	Indoor unit address 63
32	Capacity Offload Setting (SVA)	H1	00	Capacity offload function ON, initial setting
			01	Capacity offload function OFF
33	Economic Function Setting	EC	00	Power saving function OFF, initial setting
			01	Power saving function ON
34	Enforced SLo Fan Speed for Indoor Unit	PA	00	Enforced SLo fan speed ON,initial setting
			01	Enforced SLo fan speed OFF

5. Field Work Instruction

Refer to “Troubleshooting” when dealing with troubles. If the trouble cannot be solved, contact your dealer.

5.1 Caution for Refrigerant Leakage

In the room where the packaged air conditioner is installed, the refrigerant gas should be controlled not to exceed the limit concentration in case of the refrigerant leakage.

The incombustible and non-toxic refrigerant R410A is adopted for this unit. If by any chance the refrigerant gas leaks and fills the room, suffocation may occur.

Accordingly, the refrigerant charging quantity is larger than general individual unit. Before the indoor unit installation, confirm that the room can keep the lower gas concentration than the limit value in order to take the emergency countermeasures when the gas leakage occurs.

The limit concentration is calculated according to the following formula:

$$\frac{\text{Totally Charged Refrigerant Quantity in System (kg)}}{\text{Room Space for each Indoor Unit (m}^3\text{)}} \leq \text{Critical Concentration (kg/m}^3\text{)} *$$

* This value should be decided according to the each country's regulation.

If the room to install this unit is proved not to keep the gas concentration lower than the limit value, but the air conditioner should be installed in this room from unavoidable circumstances, each of the following countermeasures should be taken.

Make the effective opening for ventilation (such as opening without door or opening with over 0.15% of the floor area at the upper and lower part of the door) between one room and the next in order to keep the lower gas concentration than the limit.

- Example

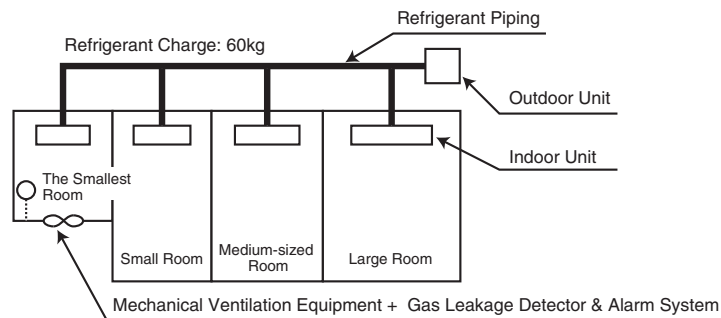

NOTE:

1. The gas leakage quantity for each room (large, medium-sized, small and the smallest) should be calculated as 60kg.
2. The gas concentration of each room should not exceed the limit value, 0.42 kg/m³ * .

* This value should be decided according to the each country's regulation.

5.2 Maintenance Work

(1) For Outdoor Unit and Indoor Unit

(a) Fan and Fan Motor

- Lubrication - All fan motors are pre-lubricated and sealed at the factory. Therefore, no lubricating maintenance is required.
- Sound and Vibration - Inspect for abnormal sound and vibration.
- Rotation - Inspect for clockwise rotation and rotating speed.
- Insulation - Inspect for electrical insulation resistance.

(b) Heat Exchanger

- Clogging - Inspect the heat exchanger and remove any accumulated dirt or dust from the heat exchanger at regular intervals. As for outdoor unit, other obstacles such as growing grass and pieces of paper, which might restrict air flow, should also be removed.

(c) Piping Connection

- Leakage - Inspect for refrigerant leakage at piping connections.

(d) Cabinet

- Stain and Lubrication- Inspect and remove any stain or lubrication.
- Fixing Screw - Inspect and fix loosened or lost screws
- Insulation - Inspect and repair peeled thermal insulation material on cabinet.

(e) Electrical Equipment

- Activation - Inspect for abnormal activation of the magnetic contractor, auxiliary relay, PCB and etc.
- Line Condition - Pay attention to working voltage, amperage and phase balance. Inspect for faulty contact caused by loosened terminal connections, oxidized contacts, foreign matter, and other items. Inspect for electrical insulation resistance.

(f) Control and Protective Devices

- Setting - Do not readjust the setting in the field unless the setting is maintained at a point other than the point listed in "Safety and Control Device Setting" of TC.

(2) For Outdoor Unit Only

(a) Compressor

- Sound and Vibration - Inspect for abnormal sound and vibration.
- Activation - Inspect for that the voltage drop of power supply line is within 16% at start and within 2% during operation.

(b) Reversing Valve

- Activation - Inspect for any abnormal activating sound.

(c) Strainer

- Clog - Inspect for that no temperature difference between both ends.

(d) Earth Wire

- Earth Line - Inspect for continuity to the earth.

(e) Crankcase Heater

- Activation - The crankcase heater should be activated at least 12 hours before start-up, by switching ON the main power source.

(3) For Indoor Unit Only

(a) Air Filter

- Cleaning - Inspect and remove any accumulated dirt or dust according to "Filter Cleaning" of manual.

(b) Drain Pan, Drain-Up Mechanism and Drain Pipe

- Drain Line - Inspect and clean the condensate drain line at least twice a year.
- Drain-Up Mechanism - Inspect for activation of drain-up mechanism.

(c) Float Switch

- Activation - Inspect for activation of float switch

5.3 Service and Maintenance Record by 7-Segment Display

Customer's Name _____

DATE: _____ - _____ - _____

Outdoor Unit Model (Serial No. _____)		(Serial No. _____)								(Serial No. _____)							
(1) Operation Mode																	
(2) Test Run Start Time																	
(3) Data Collect Start Time																	
(4) Read Out Data from 7-Segment in Outdoor Unit																	
Protection Control Code																	
Operating Capacity																	
Outdoor Total Connecting Capacity	oCP																
Outdoor Connecting Quantity	oAA																
Indoor Total Connecting Capacity	iCP																
Indoor Connecting Quantity	iAA																
Refrigerant System Address	GA																
Indoor Operating Capacity	oP																
Total Frequency	Hz																
Accumulated Operation Time of Unit	UJ																
Outdoor Unit Information																	
Outdoor Capacity	CA																
Outdoor Microcomputer Output	SC	52C ₁	52C ₂	CH ₁	CH ₂	A ₁	A ₂	21 ₁	21 ₂	52C ₁	52C ₂	CH ₁	CH ₂	A ₁	A ₂	21 ₁	21 ₂
		FAN	20B	20C	20A ₁	20A ₂	20CHG	X ₁	X ₂	FAN	20B	20C	20A ₁	20A ₂	20CHG	X ₁	X ₂
Inverter Frequency	H1																
Compressor Running Quantity	CC																
Outdoor Fan Step	Fo																
Outdoor Expansion Valve Opening	E1																
	Eb																
Discharge Pressure	Pd																
Suction Pressure	Ps																
Outdoor Temperature	To																
Discharge Gas Temperature	Td1																
	Td2																
Heat Exchanger Liquid Temperature	TE																
Heat Exchanger Gas Temperature	TG																
Liquid stop valve Temperature	Tchg																
Gas Bypass Temperature	TbG																
Inverter Fin Temperature	TFi																
Fan Controller Temperature	TFF																
Compressor Running Current	A1																
	A2																
Accumulated Operation Time of Compressor	UJ1																
	UJ2																
Accumulated Operation Time of Compressor (Available for Timer Reset)	cU1																
	cU2																
Inverter Stoppage Cause Code	iT																
Fan Controller Stoppage Cause Code	FT																
Indoor Unit Information																	
Indoor Capacity	CA																
Indoor Expansion Valve Opening	iE																
Heat Exchanger Liquid Temperature	TL																
Heat Exchanger Gas Temperature	TG																
Intake Air Temperature	Ti																
Outlet Air Temperature	To																
Indoor Unit Stoppage Cause Code	d1																

Mark	Description of Mark	Parts Mark in Wiring Diagram	Mark	Description of Mark	Parts Mark in Wiring Diagram
52C ₁	-	-	FAN	-	-
52C ₂	-	-	20B	-	-
			20C	Contactora of Relay (20C) on O.U. PCB for Solenoid Valve	SVC
CH ₁	Contactora of Relay (Y _{CH1}) on O.U. PCB for Crankcase Heater	CH1	20F ₁	-	-
CH ₂	Contactora of Relay (Y _{CH2}) on O.U. PCB for Crankcase Heater	CH2	20F ₂	-	-
20A ₁	Contactora of Relay (Y _{20A}) on O.U. PCB for Solenoid Valve	SVA			
20A ₂	-	-			
21 ₁	-	-			
21 ₂	Contactora of Relay (Y ₂₁₂) on O.U. PCB for Reversing Valve	RVR			

5.4 Service and Maintenance Record by Remote Control Switch

Data Sheet for Checking by Remote Control Switch

Time				:	:	:	:	:
I.U. Model								
I.U. Serial No.								
I.U. No. / Alarm Code								
	Check Mode 1	Check Mode 2		1 • 2	1 • 2	1 • 2	1 • 2	1 • 2
B Temp. Indication								
	Set Temp.	b1	--					
	Inlet Air Temp.	b2	q1					
	Outlet Air Temp.	b3	q2					
	Liquid Pipe Temp.	b4	q3					
	Remote Thermistor Temp.	b5	--					
	Outdoor Air Temp.	b6	q4					
	Gas Pipe Temp.	b7	q5					
	Heat Exchanger Coil Temp. of O.U.	b8	q6					
	Number of Running Compressors	b9	q7					
	Comp. Top Temp.	bA	q8					
	Thermo Temp. of Remote Control Switch	bb	--					
C Micro-Computer State Indication								
	I.U. Micro-Computer	C1	--					
	O.U. Micro-Computer	C2	--					
D Stopping Cause State Indication								
	Stopping Cause State Indication	d1	--					
E Alarm Occurrence								
	Times of Abnormality	E1	--					
	Times of Power Failure	E2	--					
	Times of Abnormal Transmitting	E3	--					
	Times of Inverter Tripping	E4	--					
F Automatic Louver State								
	Louver Sensor State	F1	--					
H Pressure, Frequency State Indication								
	Discharge Pressure	H1	q9					
	Suction Pressure	H2	qA					
	Target frequency	H3	qb					
	Operating Frequency	H4	qC					
J I.U. Capacity Indication								
	I.U. Capacity (X1/8HP)	J1	--					
	O.U. Model Code	J2	--					
	Refrigerant Cycle Number	J3	--					
	Refrigerant Cycle Number	J4	--					
L Opening of Expansion Valve								
	I.U. Expansion Valve	L1	qd					
	O.U. Expansion Valve 1	L2	qE					
	O.U. Expansion Valve 2	L3	--					
	O.U. Expansion Valve B	L4	--					
P Running Current Indication (Reference)								
	Comp. Current	P1	qF					

Client: _____
 Installation Date: _____
 System No.: _____
 Date Checked: _____
 Checked by: _____

Result	

5.5 Service & Maintenance Record

Service and Maintenance Record

No.	Check Item	Action	Judgement
1	Is service space sufficient		YES or NO
2	Short Circuit of Discharge Air?		YES or NO
3	Any Heat Influence		YES or NO
4	Is earth wire connected?		YES or NO
5	Refrigeration Piping		GOOD or NOT GOOD
6	Fixing of Units		GOOD or NOT GOOD
7	Any Damage on External or Internal Surface?		YES or NO
8	Checking of Screw and Bolts	Tighten them if they are loosened.	TIGHTENED or NOT TIGHTENED
9	Tightening of Terminal Screws	Tighten all terminal screws with a phillips driver.	TIGHTENED or NOT TIGHTENED
10	Are compressor terminals tightly fixed	Check all compressor terminals are tightly fixed	GOOD or NOT GOOD
11	Insulation Resistance	Measure insulation resistance by insulation resistance-meter. Comp. and Fan Motor: greater than 3MΩ Others: greater than 3MΩ	GOOD or NOT GOOD
12	Does drain water smoothly flow	Check for smooth flow of pouring water.	GOOD or NOT GOOD
13	Check for leakage at compressor.	Check for any leakage.	GOOD or NOT GOOD
14	Check for leakage at outdoor heat exchanger.	ditto	GOOD or NOT GOOD
15	Check for leakage at indoor heat exchanger.	ditto	GOOD or NOT GOOD
16	Check for leakage at reversing valve.	ditto	GOOD or NOT GOOD
17	Check for leakage at check valve.	ditto	GOOD or NOT GOOD
18	Check for leakage at accumulator.	ditto	GOOD or NOT GOOD
19	Check for leakage at strainer.	ditto	GOOD or NOT GOOD
20	Check for leakage at electronic expansion valve.	ditto	GOOD or NOT GOOD
21	Check for leakage at piping.	ditto	GOOD or NOT GOOD
22	Check direction of fans.	By viewing or air flow volume	GOOD or NOT GOOD
23	Voltage among each Phase.	Check the voltage is within the specified range	GOOD or NOT GOOD
24	Vibration and Sound	Check fan, compressor, piping, etc.	GOOD or NOT GOOD
25	Activation of Each Operation Mode	Check activation of COOL, HEAT, STOP and TEMP. switches.	GOOD or NOT GOOD
26	High Pressure Cut-out Switch	Check actual activation value.	GOOD or NOT GOOD
27	Check activation of drain mechanism.	Check it during cooling operation.	GOOD or NOT GOOD
28	Indoor Inlet Air Temp. (DB/WB)		°C DB/ °C WB
29	Indoor Outlet Air Temp. (DB/WB)		°C DB/ °C WB
30	Outdoor Inlet Air Temp. (DB/WB)		°C DB/ °C WB
31	Outdoor Outlet Air Temp. (DB/WB)		°C DB/ °C WB
32	High Pressure Switch		MPaG
33	Low Pressure Switch		MPaG
34	Operating Voltage		V
35	Operating Current		A
36	Instruction Cleaning of Air Filter to Client		DONE or NOT YET
37	Instruction for Cleaning Method to Client		DONE or NOT YET
38	Instruction for Operation to Client		DONE or NOT YET

5.6 Saturation Curve for Refrigerant

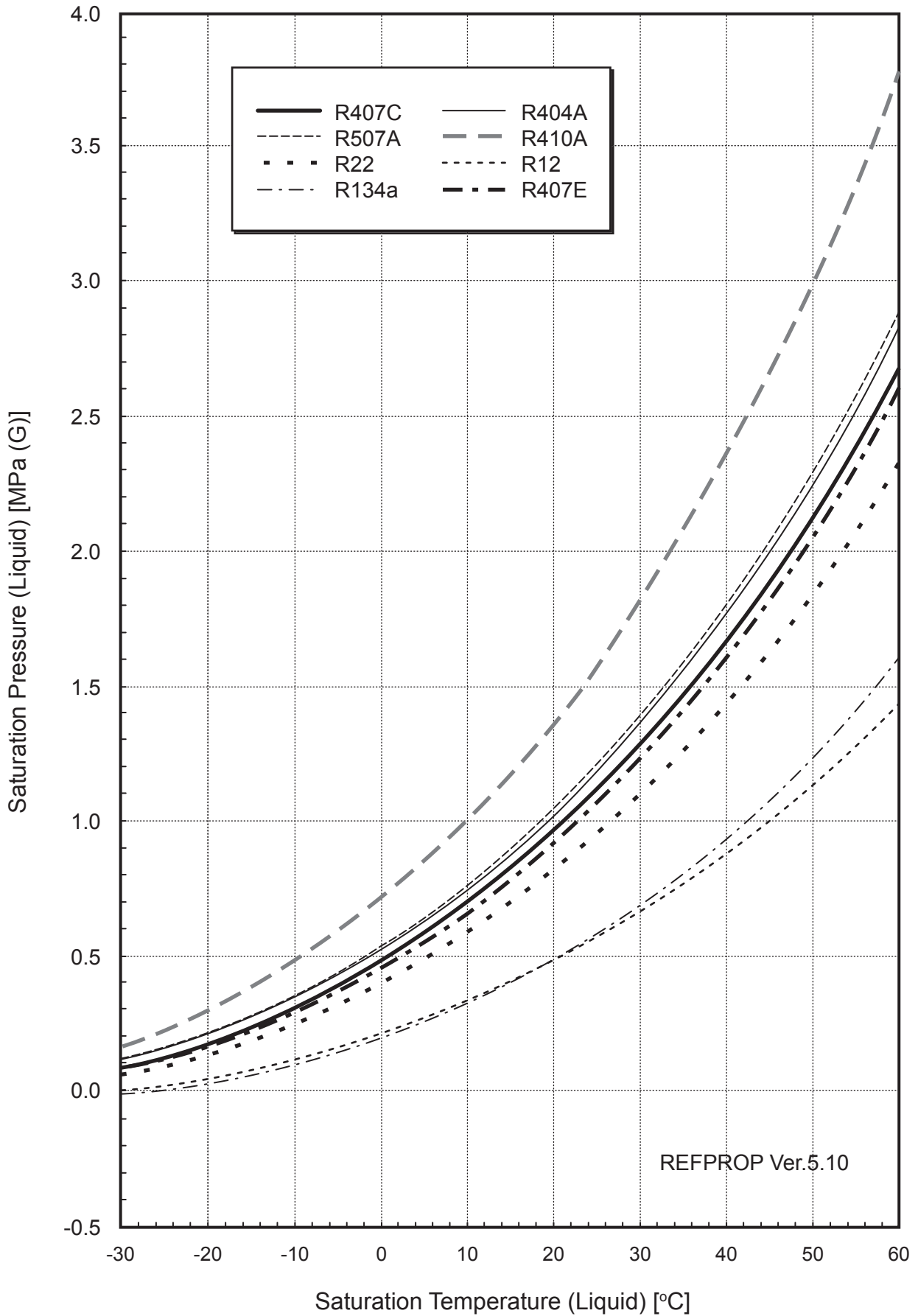

5.7 Mollier Chart for R410A

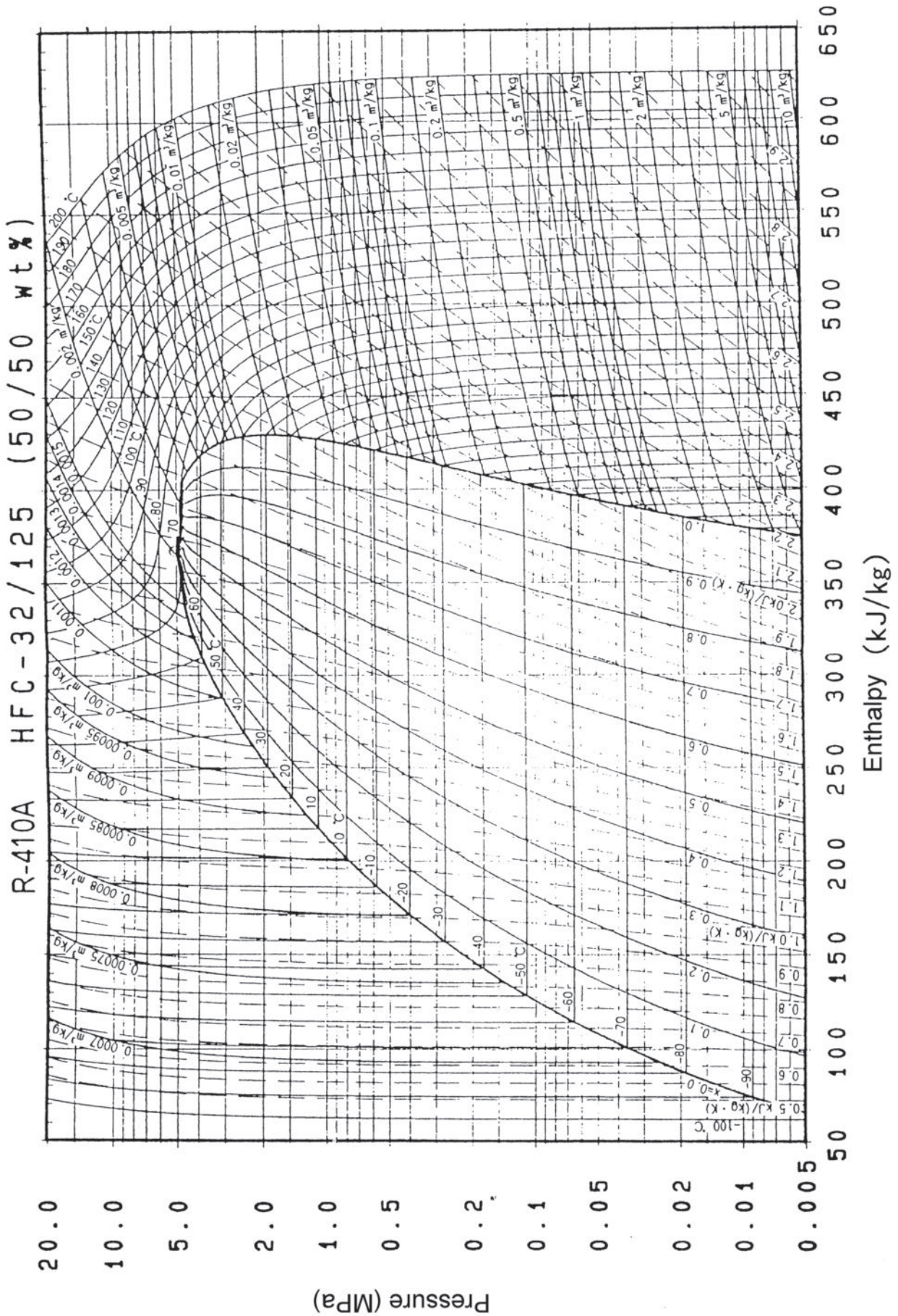

6. Test Run

**Turn OFF all the power source switches.
Use a tester and make sure that all the switches are turned OFF.**

6.1 Before test run

Before test run, check that the unit is appropriately installed according to this handbook.
After that, inspect the following items.

Check Item		Contents
1	Damage	Are the unit appearance and inside of the unit damaged?
2	Fan Motor	Is the fan motor runner mounted in the center of the casing? Is the fan motor mounted away from the casing? (The fan motor should NOT be touched with the casing.)
3	Screw Part	Are the screws loosened due to the vibration during transportation? Check that the screw part is fixed firmly when installing, especially for the screw of electrical wiring.
4	Refrigerant Leakage	Check that there is NO refrigerant leakage. The tightening part of pipe (flared part) may be loosened due to the vibration during transportation.
5	DSW Setting	Check the DSW setting is the same as before shipping.
6	Insulation*	Measure resistance between electrical component terminal and ground with a tester. It is normal if the resistance is 1MΩ and over. If 1MΩ or less, do not perform the operation due to insulation failure of electrical charge part. Do NOT apply electricity to the terminal board of operating line. (Control PCB may be damaged.)
7	Stop Valve Fully Opening	Prior to test run, check that the stop valve of the outdoor unit is completely open.
8	Power Source Phase	The operation is NOT available with the incorrect power phase order or lacking phase. • Alarm "05" will display on the LCD of remote control switch. • "05" will display on the 7-segment of outdoor unit. Check the power source phase according to the caution label attached close to the outdoor unit terminal board or rear side of the service cover.
9	Turn ON Crankcase Heater *	After completion of the check item 1 to 8, turn ON the power supply of the outdoor unit. The electricity is supplied for the crankcase heater to warm the compressor. The compressor may be damaged without preheating. Therefore, the compressor should be activated after the power supply is turned ON for at least 12 hours.
10	Indoor and Outdoor Temperature	<For Use in both Cooling and Heating Operation> Is indoor temperature DB27°C or less during heating operation? (Heating operation may not be operated due to the activation of the overload operation prevention under the ambient temperature of 19°C or over.) To perform the test run, set the test run mode by the remote control switch.

<* Insulation Resistance>

In case that the unit has been turned OFF for long periods, insulation resistance may decrease to 1MΩ or less because the refrigerant is retained in the compressor. Check the following points.

- (a) Disconnect the cables of the compressor and measure the insulation resistance of the compressor itself. If the resistance is 1MΩ and over, insulation failure of other electrical charge part has occurred.
- (b) If the resistance is 1MΩ or less, reconnect the compressor and turn ON the main power supply. The compressor will be warmed up automatically. Check the insulation resistance again after applying current for at least 3 hours. (Preheating time depends on the air condition, piping length or refrigerant condition.)

Before the leakage breaker is activated, check the rated capacity.

<* Stoppage of Compressor Operation>

The compressor may NOT be available for the max. 4 hours if the power supply is NOT turned ON in advance.

At this time, the stoppage Code (d1-22) is displayed on the LCD of remote control switch and the forced Thermo-OFF function is started.

If operating compressor is necessary, turn ON the power supply of outdoor unit, wait for 30 seconds and press PSW5 on the outdoor PCB for at least 3 seconds. The forced Thermo-OFF function (d1-22) will be canceled and the compressor operation will be available.

6.2 Test Run

6.2.1 Test Run by Remote Control Switch

Refer to Operation Manual for Remote Control Switch .

6.2.2 Test Run from Outdoor Unit Side

The procedure of test run from the outdoor unit side is as shown below. Setting of this dip switch is available with the power source ON.

Setting of Dip Switch (Before Shipment)

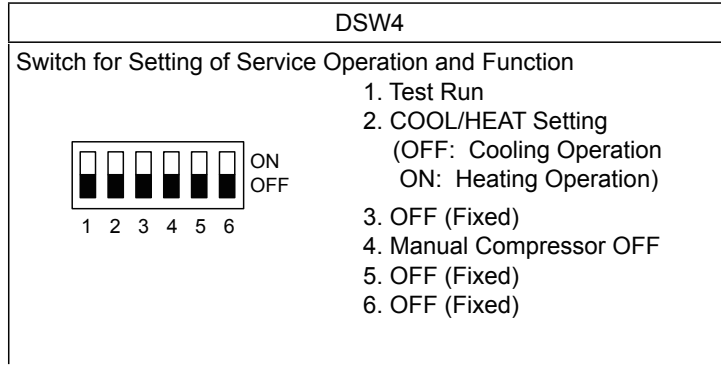

! WARNING

- Do not touch any other electrical parts when operating switches on the PCB.
- Do not attach or detach service cover when the power source for the outdoor unit is ON and the outdoor unit is operated.
- Turn all the dip switches of DSW4 OFF when the test run operation is completed.

	Dip Switch Setting	Operation	Remarks
Test Run	<p>1. Setting of Operation Mode Cool: Set DSW4-2 OFF.</p> <p>Heat: Set DSW4-2 ON.</p> <p>2. Starting Test Run Set DSW4-1 ON and the operation is started after a few ~ 20 seconds.</p> <p style="text-align: center;">When heating operation, ↓ leave DSW4-2 at ON.</p>	<ol style="list-style-type: none"> 1. The indoor unit automatically starts to operate when the test run of the outdoor unit is set. 2. The ON/OFF operation can be performed from the remote control switch or DSW4-No.1 of the outdoor unit. 3. Continuous operation during 2 hours is performed without Thermo-OFF. 	<p>* Take care that the indoor units operate in accordance with the test run operation of the outdoor unit.</p> <p>* The test run is started from the outdoor unit and stopped from the remote control switch, the test run function of the remote control switch is canceled. However, the test run function of the outdoor unit is not canceled. Check to ensure that the DSW4-No.1 of the outdoor unit PCB is turned OFF.</p> <p>* In case that the plural indoor units are connected with one remote control switch, perform the test run operation at each refrigerant system one by one. Then, make sure to turn the power source OFF for the indoor units at other refrigerant system not to operate test run.</p> <div style="text-align: center;"> </div> <p>* The setting of DSW4 is not required for the test run from the remote control switch.</p>

	Dip Switch Setting	Operation	Remarks
Manual OFF of Comp.	<p>1. Setting *Compressor Manual OFF: Set DSW4-No.4 at ON.</p> <p>1 2 3 4 5 6</p> <p>2. Reset *Compressor ON: Set DSW4-No.4 at OFF.</p> <p>1 2 3 4 5 6</p>	<p>1. When DSW4-No.4 is ON during compressor operation, the compressor stops to operate immediately and the indoor unit is under the condition of Thermo-OFF.</p> <p>2. When DSW4-No.4 is OFF, the compressor starts to operate after the cancellation of 3-minute guard.</p>	<p>* Do not repeat compressor ON/OFF frequently.</p>
Manual Defrost	<p>1. Manual Defrost Operation Press PSW5 for more than 3 seconds during heating operation, the defrost operation is started after 2 minutes. This function is not available within 5 minutes after starting heating operation.</p> <p>2. Manual Defrost Operation Completion Defrost operation is automatically ended and the heating operation is restarted.</p>	<p>1. Defrost operation is available regardless of frosting condition and total time of heating operation.</p> <p>2. Defrost operation is not performed when the temperature of outdoor heat exchanger is higher than 10°C, high pressure is higher than 3.3MPa or Thermo-OFF.</p>	<p>* Do not repeat defrost operation frequently.</p> <p>* When manual defrost operation is accepted by PSW5, the time left before starting defrost operation displays at the 7-segment indicator on the PCB.</p> <p>Time Left (Every 4 Seconds)</p>

When the test run operation is completed, set all switches of DSW4 at OFF.

6.2.3 Checking at Test Run

(1) Indoor and Outdoor Fan

Inspect that the indoor fan and outdoor fan rotate correctly and the air flow is smooth.

(2) Power Supply Voltage

Check the power supply.

If the power supply is abnormal, contact with electric power company.

Usually, voltage drop will occur when starting as shown in the figure (V₂).

In order to protect device, comply with the following normal range of the power supply voltage.

<Normal Range of Power Supply Voltage>

- Supply Voltage: Rated Voltage ±10%
- Starting Voltage (V₂): Rated Voltage -15%

< Voltage Change >

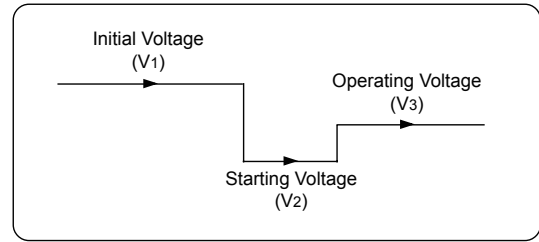

Operating Voltage (V₃): Rated Voltage ±10%

Voltage Imbalance between Phase: ≤3%

(3) Normal Operating Pressure

Normal operating suction pressure is 0.2 to 1.1MPa and normal operating discharge pressure is 1.0 to 3.5MPa when the refrigerant charge is correct. Check the operation pressure by the test run mode.

(4) High Pressure Switch

Check the operation pressure of the high pressure switch in the table below.

Refrigerant	Operation Pressure
R410A	4.15MPa

(5) High Pressure Increase Retry (Protection Control)

(a) The high pressure will be increased when the following procedure is performed.

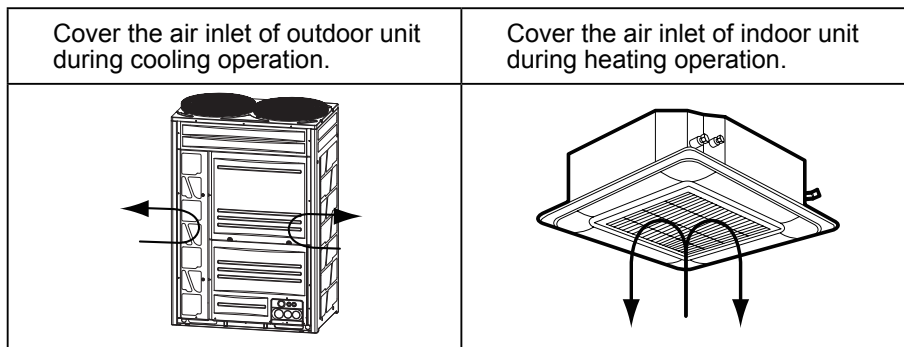

(b) When the high pressure retry control is activated, alarm code “P1” will display on the 7-segment of outdoor unit PCB. If the high pressure retry control occurs 3 times or more within 30 minutes, alarm code “ ” will display on the LCD of remote control switch or the 7-segment of outdoor unit PCB.

NOTE:

The high pressure may not increase until the high pressure switch is activated due to the temperature condition.

6.2.4 Checking List for Refrigerant Cycle

The refrigerant cycle data can be checked on 7-segment of outdoor unit PCB during the test run and the troubleshooting. However, it may take time for the checking because the operation cycle changes depending on the operating condition.

To check the quality of refrigerant cycle, the following check list shall be used at the test run, troubleshooting and emergency check.

(1) Refrigerant Cycle Check

The most important thing in the refrigerant cycle check is to check that each expansion valve opening and the operating frequency is within the specified range. Each item varies in the value depending on the operating frequency, indoor temperature and ambient temperature.

(2) The service system tester, which automatically calculates Td and SH, facilitates the refrigerant cycle check. If possible, record the operating cycle data by the service system tester.

CHECK LIST ON TEST OPERATION

CLIENT: _____ INSTALLER: _____ DATE: _____

O.U. MODEL: _____ O.U. SERIAL NO.: _____ CHECKER: _____

I.U. Model							
I.U. Serial No.							

I.U.: Indoor Unit, O.U.: Outdoor Unit

Piping Length: _____ m Additional Refrigerant Charge: _____ kg

(1) General

No.	Check Item	Result
1	<Combination of Base Units> Is DSW6 setting for outdoor unit No. correct?	
2	Are the power source wire and the transmitting wire apart from refrigerant pipings?	
3	Is an earth wire connected?	
4	Is there any short circuit?	
5	Is there any voltage abnormality among each phase? (L1-L2, L2-L3, L3-L1)	

(2) Refrigerant Cycle

a. Operation (Cooling)

No.	Check Item	Result
1	Operate all the units ("TEST RUN" mode).	
2	Operate all the indoor units at "HIGH" speed.	
3	In case that the constant compressor is turned ON and OFF repeatedly, switch off an indoor unit (with a small capacity).	

b. Sampling Data (Cooling, Indoor Temperature 21~30oC)

No.	Check Item	Result
1	Check the operating data after 20-minute operation.	
2	Check Pd and Td. Is Td-SH 15 to 45oC ?	
3	Is Ps 0.15 to 1.3 MPa?	
4	Is Pd 1.0 to 3.6 MPa? (If the outdoor temperature is high, Pd becomes high.)	

NOTE:

The symbol with an underline _____ indicates checking item.

(3) Check Item after Sampling Data

Cooling Operation (It is applicable when outdoor temperature is higher than 15°C.)

No.	Check Item	Standard	Causes	Result
1	Is fan actually running when Fo (Air Flow Rate of O.U. Fan) is not "0"?	-	<ul style="list-style-type: none"> • Fan Motor Failure • O.U. PCB Failure • Condenser Failure 	
2	Is the total of iE (I.U. Ex. Valves Opening) abnormally low or high?	-	<ul style="list-style-type: none"> • Low Excessive Refrigerant • High Insufficient Refrigerant or Excessive Pipe Pressure Loss 	
3	Is TL (Liquid Pipe Temp. of I.U. Heat Exchanger) lower than Ti (Intake Air Temp. of I.U.)?	It is normal when TL-Ti < -5 °C	<ul style="list-style-type: none"> • TL Thermistor Failure • I.U. Ex. Valve; Fully Closed • Short-Circuit 	
4	Is TG (Gas Pipe Temp. of I.U. Heat Exchanger) lower than Ti (Intake Air Temp. of I.U.)? (It is applicable when Intake Air Temp. is 3 °C. higher than Setting Temp.)	It is normal when TG-Ti < -5 °C.	<ul style="list-style-type: none"> • TG Thermistor Failure • I.U. Ex. Valve; Fully Closed or Slightly Open • Short-Circuit 	
5	Is there any excessive difference in SH (TG-TL) of I.U. heat exchanger among I.U.s? (It is applicable when Intake Air Temp. is 3 °C. higher than Setting Temp.)	It is normal if the difference among units is within 7 °C.	<ul style="list-style-type: none"> • TL/TG Thermistor Failure • I.U. Ex. Valve; Fully Open, Slightly Open or Fully Closed" 	
6	Is there any I.U. with the I.U. heat exchanger SH (TG-TL) excessively lower than the other units' value and is iE (I.U. Ex. Valves Opening) lower than "5"?	It is normal if SH of the unit is up to 3 °C lower than the other units.	<ul style="list-style-type: none"> • I.U. Ex. Valve; Locked and Fully Open • Mismatched Wiring and Piping 	
7	Is there any I.U. with the I.U. heat exchanger SH (TG-TL) excessively lower than the other units' value and is iE (I.U. Ex. Valves Opening) lower than "100"?	It is normal if SH of the unit is up to 3 °C higher than the other units.	<ul style="list-style-type: none"> • I.U. Ex. Valve; Locked and Slightly Open or Closed • Mismatched between Wiring and Piping 	
8	Is the temperature difference between I.U.s* more than 7 °C? * The temperature difference between I.U.s means the following; b3 (Discharge Air Temp.) - b2 (Intake Air Temp.) displays on the remote control switch by check mode.	7 °C and over	-	

Heating Operation (It is applicable when outdoor temperature is higher than 0°C.)

No.	Check Item	Standard	Causes	Result
1	Are <u>oE1</u> and <u>oE2</u> (O.U. Ex. Valves Opening) abnormally low or high when TdSH is 15 to 45 °C ?	-	<ul style="list-style-type: none"> • Low → Excessive Refrigerant • High → Insufficient Refrigerant 	
2	Is <u>Pd</u> "1.6" to "3.6"?	1.6 -3.6 (Pd is high when the indoor temperature is high.)	<ul style="list-style-type: none"> • Low → Solenoid Valve SVA Leakage • High → Excessive Gas Pipe Pressure Loss 	
3	Is <u>Ps</u> "0.15" to "1.3"?	0.15 - 1.3	<ul style="list-style-type: none"> • Low → O.U. Short-circuit • Low/High → O.U. Fan • Motor Failure, Fan Module Failure or Outdoor Ambient Thermistor Failure 	
4	Is the temperature difference between I.U.s* more than 10 °C when iE (I.U. Ex. Valve) is "100"? * The temperature difference between I.U. means the following; b3 (Discharge Air Temp.) - b2 (Intake Air Temp.) displays on the remote control switch by check mode. However, this is applicable only when b2 (Intake Air Temp.) - b1 (Setting Temp.) is higher than 3 °C.	10°C and over	<ul style="list-style-type: none"> • Failure in PCB, Wiring, I.U. Ex. Valve and Coil • Excessive Pipe Pressure Loss • Thermistor Failure for Discharge Air 	

NOTE:

The symbol with an underline indicates checking item and the quotation mark indicates checking data.