



## Customer First, Service Foremost

- Focus on Today's Requirement
- Why Choose Hisense VRF Solutions
- Strict Quality Control
- Comprehensive Air Conditioning Solutions
- Overall Support for Customers
- Benefit for End Users

# Focus on Today's Requirement

# Focus on Today's Requirement

## Focus on Energy Conservation

According to the statistics from authority, building energy consumption takes up 35%~50% of the main energy consumption. And air-conditioning is a big consumer of building energy consumption, taking up about 40%~60%. So it is very important to effectively reduce the air conditioning energy consumption.

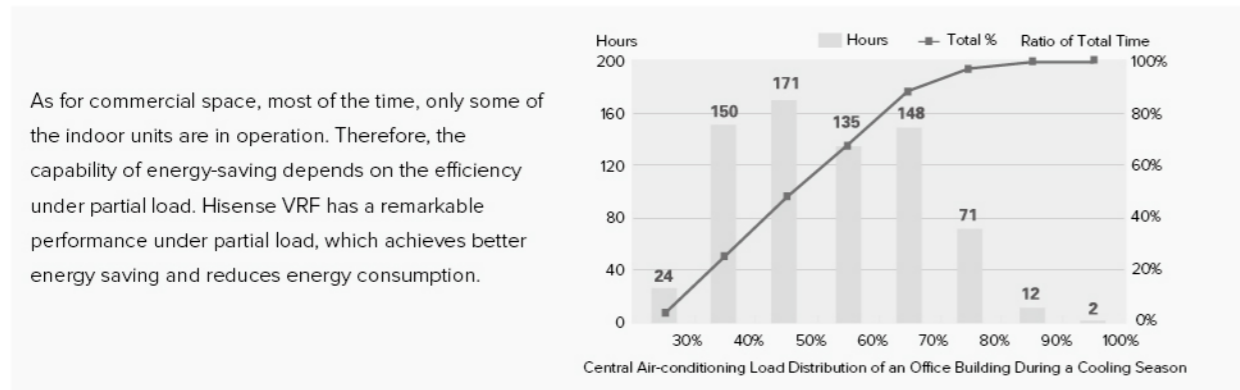

Hisense heat recovery Hi-FLEXi R series realizes simultaneous cooling and heating through perfect combination of DC inverter technology and heat recovery technology, which realizes a 20% energy saving compared with traditional air conditioning, achieving lower running cost.

## Focus on Environmental Protection

### R410A Refrigerant, Protect Ozone Layer

Hisense VRF products adopt efficient and reliable environment-friendly refrigerant R410A, which is non-toxic to humans and will not damage the Earth's ozone layer, create a comfortable, clean living environment for you.



### RoHS Reaction

Actively respond to Europe RoHS directive, control the use of hazardous substance strictly. RoHS stands for Restriction of Hazardous Substance Directive, which specifies six substances (Lead (Pb), Mercury (Hg), Cadmium (Cd), Hexavalent chromium (Cr), PBDE or PBB) banned from using in electrical and electronic equipment. Hisense actively responded to RoHS directive and implemented a series of programs and measures, which aims to preserve human health and ensure that the recycling and treatment of wasted electronic and electrical equipment meet the environmental standard.



## Focus on Healthy Indoor Environment

### Sophisticated Antibacterial Technology

Hisense high performance antibacterial filter adopts double-layer antibacterial structure ( long-acting antibacterial filter and high performance antibacterial filter ), which can purify indoor air, restrain and kill bacteria, as well as inhibit the reproduction of bacteria and mould on the high performance filter material and maintain fresh air in room.

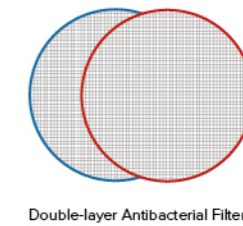

### Fresh Air Introduction

Hisense VRF system can introduce outdoor fresh air into indoor space through All Fresh Air Indoor Unit and Total Heat Exchanger, which constantly remains the indoor oxygen content and interior freshness and creates a healthy environment for people's live.



## Noise Control

The creation and use of mechanical equipment has brought human prosperity and progress, but noise pollution has been increasingly strong in recent years. As we all know noise pollution has lots of negative effects on our relaxation, work, study, and even on our health, so noise control is becoming more and more significant. Hisense realizes excellent noise control through a series of improvement on compressor, fan motor and fan structure. The noise level of outdoor units has been reduced dramatically, and the lowest noise level of Hisense indoor units is down to 21dB.

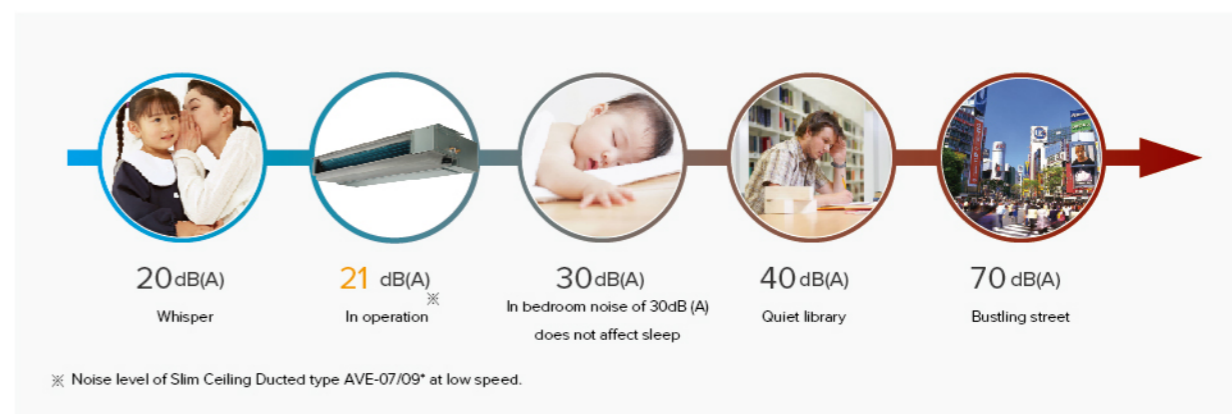

# Why Choose Hisense VRF Solutions

# Strict Quality Control

## High Technology and Outstanding Operation Performance

Based on high technology and manufacturing ability, Hisense has been developing rapidly these years. And Hisense has gained great reputation in the commercial air conditioning field. Hisense adopts strict quality control standard during the manufacturing and test process, ensuring best quality of products. Hisense VRF's outstanding operation performance and system reliability ensures low running cost over its entire service time.

## Comprehensive Product Lineup

Hisense VRF provides a comprehensive product lineup including air cooled outdoor unit, water cooled outdoor unit, meeting different application conditions. And Hisense also provides many types of indoor units with more than 100 models, you can choose the suitable indoor unit according to the practical situation and decoration style, creating personalized living and working space.

## Modular Combination Design Gives Greater Flexibility

Hisense VRF's modular combination design provides a greater flexibility to balance heat loads in different parts of the building. And the double backup function ensures the system has certain output when malfunctions occurred in one modular of the combined system. In contrast, a chiller unit runs the whole system, which requires an expensive backup unit to avoid a complete stop. So if it fails, the total system will stop working. VRF products also offer extended piping lengths so that the system can be designed flexibly to satisfy buildings with different sizes and structures.

## Higher Space Efficiency

VRF system is much more space efficient than a chiller unit, because it doesn't require special operation room and much less floor space is needed. It is estimated by authority that a 2 or 4 pipe fan coil system could take up around 7% of the overall lettable floor area of the building, while a comparable VRF building would take up between 3-5%. This means that Hisense VRF allows developers to maximise the rental space. Hisense also have outdoor units with different structures to meet different installation spaces, which greatly improve the installation flexibility. The most flexible and efficient use of office space will be really helpful to win more projects in this highly competitive market.

## Easier Transportation and Installation

The compact and light weight design make Hisense VRF much easier to be transported and installed. The outer dimension of the largest base modular is 1,720×1,210×750mm with a floor area of 0.9m<sup>2</sup> and a weight of 318Kg, so the outdoor units can be transported separately by the elevator, which improves the installation efficiency dramatically and lower the installation cost.

## Intelligent Control System

Industry-leading inverter control technique is adopted in Hisense VRF products, so the control accuracy and reliability of the inverter are greatly improved. There are multiple thermal sensors in the system, which will make real-time detection and feedback, so the temperature will be precisely controlled.

Hisense VRF products are compatible to BMS and Smart Home control system, which makes it much easier to realize central control and monitoring. Air conditioning electric charge allocation system helps the building owners and users to monitor the energy consumption and better expense control.

There are various intelligent controllers for selection, realizing more intelligent and convenient control.

Hisense's production base is located in Hisense Information Industrial Park in Qingdao Economic Development Zone with a total area of about 80,000 square meters. The annual output is more than 1.1 million units.

Hisense possesses state-level technology center. With the discipline of "Technology Oriented", the research and development group has been dedicating itself to improvement of product features and new technologies, by developing and growing stronger constantly, the superb manufacturing process and technical level making Hisense at top level in the industry all the time.

## Computer Simulation Development---the Most Advanced and Energy Saving Development Mode

In Hisense, the most advanced computer simulation technology is applied to all the new products. From the original design, modeling to the later-stage performance test and any other necessity till the finally product is formed. This development mode not only accelerate the developing process, but also can reduce plenty energy consumption during the developing stage.

## Excellence-led Manufacture Mode---Efficiency and Energy Saving

To realize the smooth assembling and zero-stock of spares, Hisense conducts the excellence-led manufacture mode to guarantee the high quality, high efficiency as well as low energy consumption. Make real low-carbon product.

## Strict Quality Control and Component Test---High Quality, High Efficiency and Low Energy Consumption

Hisense applies full range of Japan imported inspection facility aided by extremely strict quality inspection system and standard to guarantee the reliable quality of every single components of any machine and offer the end users a green life with superior quality product.



# Comprehensive Air Conditioning Solutions

# Comprehensive Air Conditioning Solutions

## Air Cooled Outdoor Systems

### Heat Pump - for Either Heating or Cooling Operation From One System



8-54HP

#### **HI-FLEXI** G series

Latest Full DC inverter series with large capacity range, realizing significant improvement in operation efficiency under partial load. Reliable operation and intelligent control make HI-FLEXi G series a perfect choice for your air conditioning solution. Compact structure and light weight, making it much easier for transportation and installation.



8-48HP

#### **HI-FLEXI** M series

Advanced multi-split technology improves the system performance and energy efficiency. Flexible design and installation provides better air conditioning solution for workplace, leisure and living space.



8/10/12HP

#### **HI-FLEXI** C series

Hi-FLEXi C series aim at improving the comfort of space; every detail is fully considered in the process of design and installation, accordingly bring you completely new space experience. Front flow structure greatly improves the flexibility in installation.

### Heat Recovery - for Simultaneous Heating and Cooling Within One System



8-54HP

#### **HI-FLEXI** R series

Realizing simultaneous heating and cooling operation within one refrigerant system, which not only meets various requirements of different customers, but also contributes to energy conservation. Flexible design and installation provide better air conditioning solution for workplace, leisure and living space.

## Water Source Application Systems



3-20HP

#### **HI-FLEXI** W series

Wide application ranges include surface water circuit, underground water circuit, seawater source, urban sewage source, soil source. Allows heat recovery within one system because of the storage of energy in the water circuit. Suitable for multi-story and large building due to the many possibilities of water piping.

## Hisense Mini VRF System



4/5/6HP

#### **HI-Smart** L series

Hi-Smart L Series, household central air conditioning system, is specially designed for medium and large high-end real estate. The outstanding appearance and function design, the application of leading technology and high quality components make it a perfect choice for users.

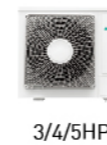

3/4/5HP

#### **HI-Smart** E series

Hi-Smart E Series, household central air conditioning system, of which the compact outdoor units bring high flexibility of installation and maintenance, and with the light and slim indoor units creates an elegant and high taste domestic environment.

## Fresh Air Ventilation System



660~6,000m<sup>3</sup>/h

#### All Fresh Air Indoor Unit

All fresh air indoor unit is an independent ventilation device with cooling and heating source, it can provide plenty of fresh air to the house to guarantee the air quality, preventing the cross infection. The air flow rate is from 660m<sup>3</sup>/h to 6000m<sup>3</sup>/h, which can satisfy the need of large space.



150~5,000m<sup>3</sup>/h

#### Total Heat Exchanger

The total heat exchanger realizes the heat exchange between supply air and return air, realizing heat recovery and ventilation without increasing air conditioning load. The outdoor fresh air is filtered by the filter equipped in the unit, and then the cool or warm fresh air is transported to every room through the air duct.



4~20HP

#### AHU Solution for Air Handling Applications

The Hisense AHU-KIT can integrate external heat exchangers of air handling units (AHU) into a Hisense VRF system to be used for air conditioning, which can provide more flexible air conditioning solutions and save more renovation cost in the building air conditioning renovation.

# Overall Support for Customers

Echoing the service idea of "Customer First", Hisense is making efforts to provide overall support to our customers, including product promotion, air conditioning solution design, installation and commissioning, maintenance, etc. Meanwhile, Hisense has professional training team, related training facility and on-line training platform to conduct a comprehensive training on products, AC solutions design, installation and commissioning to our customers.

## New Product Training and Promotion

Before any new product is launched into the market, we will provide detailed product specification, related promotion material as well as related training courses to help our customers have an overall understanding on the new product.

## Air Conditioning Solutions Design

A good design is the foundation of installation and commissioning. Hisense has a special department—Customer Support Department, to offer VRF solutions with a series of professional designing softwares ( Selection software, Design software and CFD software ). Hisense will give a professional VRF solution in a rapid period when customers pass down their requirements.

## Support For Installation and Commissioning

VRF can run stably and reliably only if it is installed correctly and regularly. Hisense is very strict with the product quality control as well as the installation. All the installers must attend and pass the specific training to get authorization to install our machines and we have standard installation video and billboard to assist. Besides, we will dispatch professional technicians if necessary to give guidance and supervision to guarantee standardization of the installation and commissioning.



# Overall Support for Customers

## Selection Software

With the philosophy of All for Users, Hisense developed a Central Air Conditioning Selection Software which not only helps users to choose proper Hisense equipment but also to do the central air conditioning system design work. This software makes the specialized central air conditioning project design work more simply and realistic for nonspecialist. Whether you are a consultant or a salesman, you can work out a systematic piping and wiring diagram with its user-friendly interface. Furthermore, a quick quotation of a project can be provided with the selection of equipment and installation material.

<b>Project Information</b> Project information input Choose power supply Choose temperature condition	<b>Indoor Unit Selection</b> Room information input Cooling and heating load calculation Automatic & manual indoor unit selection
<b>Outdoor Unit Selection</b> Choose connection ratio Match indoor units and outdoor units Automatic & manual outdoor unit selection	<b>Capacity Correction</b> Pipe length and height difference input Indoor and outdoor unit correction Poor capacity warning
<b>Piping Diagram</b> Automatic & manual outdoor and indoor unit pipe connection Branch pipe selection Segmental pipe length input Automatic connection error warning Pipe size calculation	<b>Wiring Diagram</b> Power and communication cable connection Cable size calculation Terminals connection Controller connection
<b>Central Control Diagram</b> Central controller connection BMS diagram	<b>Reports Output</b>

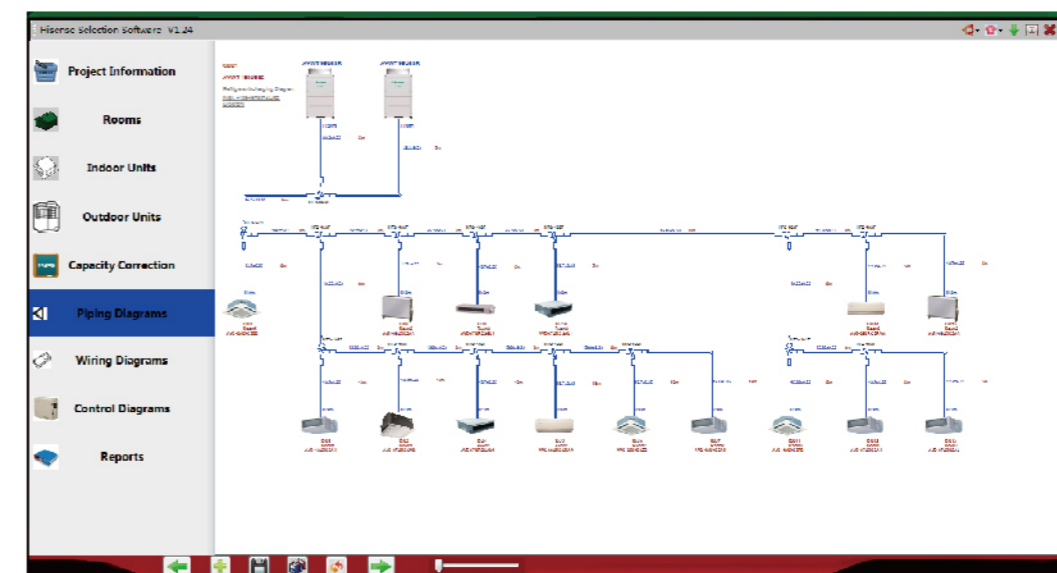

# Overall Support for Customers

# Benefit for End Users

## Data Collector

### Main Function

- Hisense VRF test run
- Recognize warning and error
- Maintenance and monitoring
- Central control test

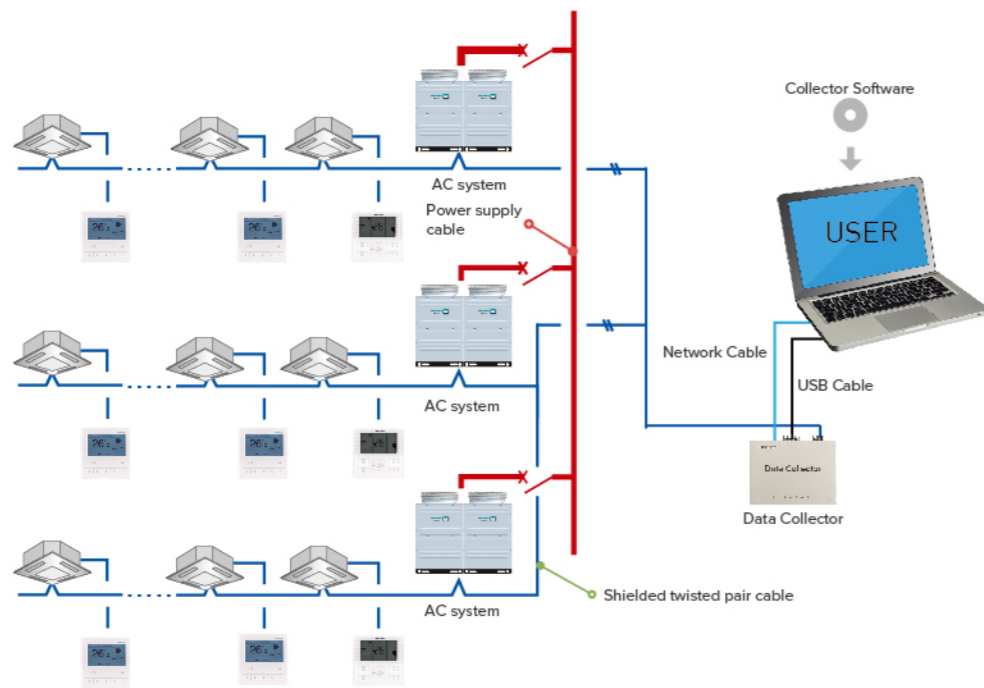
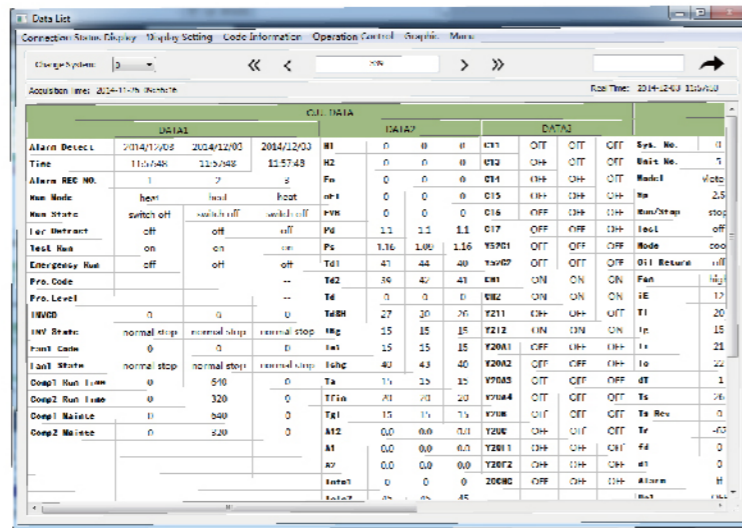

Note: The data collector can be powered by the USB, but if it needs to use it for a long time, we recommend to use more stable external power supply.

Power Supply	DC12V or USB power supply
Power Consumption	Below 1.5W
Dimensions	L×W×H: 180mm×110mm×40mm
Weight	0.55kg
Wire range	Less than 1000m
Connected IDU NO.	128 IDUs
One checker software can only be connected to one checker hardware.	

## Precise Temperature Control

Hisense indoor units adopt 2000-Steps electronic expansion valves, which can make precise refrigerant flow adjustment automatically according to the actual load of indoor units with more accurate temperature regulation. There are multiple thermal sensors in the system, which will make real-time detection and feedback on the outdoor temperature, indoor temperature and outlet air temperature etc. The temperature is maintained within 0.5°C of the set temperature.

## Top-class Low Noise Level in Operation

The lowest noise level of Hisense indoor units in operation is down to 21dB (A), so they create great comfort for end users while meet the common air-conditioning demand.

## Various Types of Indoor Units for Selection

Hisense Hi-FLEXi and Hi-Smart series provide a wide selection of indoor units for different spaces and decoration styles, creating personalized living space.

## Intelligent Controls

Hisense provides various controllers and control schemes, which helps end users enjoy the great convenience brought by the improvement of technology while meets the common air conditioning demand.

